

U.S. Department
of Transportation

United States
Coast Guard



TOWER MANUAL

**COMDTINST M11000.4A
JANUARY 2002**



COMDTINST M11000.4A
JAN 11 2002

COMMANDANT INSTRUCTION M11000.4A

Subj: TOWER MANUAL

1. PURPOSE. This Manual defines Coast Guard policy and criteria for the preservation of towers and prescribes minimum inspection and maintenance standards for use as a guide in organizing and managing a comprehensive tower inspection and maintenance program.
2. ACTION. Commanders of Maintenance and Logistics Commands shall ensure that the provisions of this Manual are followed. Internet release is authorized.
3. DIRECTIVES AFFECTED. The Tower Manual, COMDTINST M11000.4, is cancelled.
4. DISCUSSION. The previous edition of the Tower Manual, COMDTINST M11000.4A, was written in 1978 with the last changes made in 1982. Although much of the information in the manual was applicable to the current tower program, the manual primarily addressed tall guyed towers, specifically OMEGA and LORAN. The Coast Guard's tower inventory is growing annually and has changed significantly over the past 20 years. The majority of Coast Guard towers today are small towers under 300ft that received only cursory attention in the previous edition. Secondly, safety requirements and equipment have also improved steadily and the most significant change to this revision is in the tower safety chapter. Due to the large volume of new information and required changes, the old Tower Manual, COMDTINST M11000.4, is cancelled in its entirety. The new Tower Manual, COMDTINST M11000.4A, has been reorganized and streamlined for quicker and easier access to information.
5. MAJOR CHANGES. Major changes from the previous version of the Manual include: new tower definitions, more detailed requirements for tower safety, establishment of Tall Tower Coordination Center, new recommended inspection routines and items, updated tower failure information, incorporated portions of various unit level small tower handbooks, new information on antenna installation and removal, eliminated dated information relating to OMEGA and ACTEUR towers, new information on tower marking systems in accordance with latest FAA Advisory Circulars, new information on alignment and twist methods, updated information on guy tension methods,

DISTRIBUTION – SDL No. 139

	a	b	c	d	e	f	g	h	i	j	k	l	m	n	o	p	q	r	s	t	u	v	w	x	y	z
A																										
B	*	2	5		2			2	1				2	2	2			30	10			20			10	
C						2	10*				2	2					5					2	1			
D																				5						
E								2																		
F																										
G																										
H																										

NON-STANDARD DISTRIBUTION: B:a G-S (5), G-O (5); C:g CEU OAKLAND (30)

COMDTINST M11000.4ACOMDTINST M11000.4A

established new recommended formats for tower inspection reports for both small and tall towers, and updated information on LORAN base insulator replacements.

REQUEST FOR CHANGES. Units and individuals may recommend changes by writing via the chain of command to Commandant (G-SEC), U.S. Coast Guard Headquarters, Washington, DC 20593-0001.



R. F. SILVA
ASSISTANT COMMANDANT FOR SYSTEMS
"CHIEF ENGINEER"

TABLE OF CONTENTS

TABLE OF CONTENTS.....	i
CHAPTER 1. INTRODUCTION.....	1-1
A. Purpose and Scope.....	1-1
B. Responsibilities.....	1-1
C. Inspection and Maintenance Standards and Costs.....	1-1
D. Revision of Manual.....	1-1
CHAPTER 2. TOWER SAFETY.....	2-1
PART I. GENERAL CLIMBING SAFETY	2-1
A. Safety Policy and Requirements.....	2-1
B. Buddy System.....	2-1
C. Climbing of Towers by Coast Guard Personnel.....	2-1
D. Minimum Requirements.....	2-2
E. Equipment.....	2-2
F. Pre-Climb Safety.....	2-5
G. Conditioning and Mechanics of Climbing.....	2-6
H. Rescue.....	2-7
PART II. GENERAL TOWER SAFETY	2-8
A. Climbing of Towers by Contractor.....	2-8
B. Work on Energized Towers.....	2-8
C. Maintenance of Energized Towers.....	2-9
D. Ladders and Safety Climbing Devices.....	2-9
E. Protective Barriers and Warning Signs.....	2-10
CHAPTER 3. INSPECTION GUIDELINES.....	3-1
A. General.....	3-1
B. Inspection Categories.....	3-1
C. Inspection Objectives and Requirements.....	3-2
D. Tower Failures.....	3-7
CHAPTER 4. MAINTENANCE GUIDELINES.....	4-1
A. Maintenance Objectives and Requirements.....	4-1
B. Maintenance, Repair, and Modification.....	4-3
C. General Inspection and Maintenance Problems.....	4-4
D. Common Abnormalities.....	4-8
E. Replacement of Structural Members.....	4-11
CHAPTER 5. TOWER STRUCTURE.....	5-1
A. General.....	5-1
B. Standard Tower Leg and Face Designations.....	5-1
C. Structural Members.....	5-1
D. Base Insulators.....	5-10
E. Tower Base.....	5-13
F. Ladder Safety Rail, and Rest Platforms.....	5-16
G. Hoists and Elevators.....	5-16
H. Ground Systems.....	5-16
I. Tower Jacking Legs.....	5-17
J. Spare Parts.....	5-17
K. Antenna Installations.....	5-18
L. Antenna Removals.....	5-18
CHAPTER 6. GUYS AND GUY ANCHORS.....	6-1
A. General.....	6-1
B. Standard Guys, Guy Anchor and Insulator Designations.....	6-1
C. Guy Cables and End Fittings.....	6-3
D. Wire Strand and Rope.....	6-3
E. Galvanized Steel Cable.....	6-6
F. Aluminum Coated Steel Cable.....	6-6

	G. Reinforced Aluminum Conductors.....	6-6
	H. Copper Coated Steel Cable.....	6-7
	I. Cable End Fittings.....	6-7
	J. Inspection and Maintenance.....	6-10
	K. Guy Cable Hardware.....	6-13
	L. Insulators.....	6-17
	M. Gradient Cones and Arcing Rings.....	6-25
	N. Tower Anchors.....	6-26
	O. Tower Guy Accessories.....	6-28
CHAPTER 7.	TOWER PAINTING.....	7-1
	A. General.....	7-1
	B. Maintenance of Tower Painting.....	7-2
	C. Standard Tower Painting Systems.....	7-3
	D. Alternative Painting Systems.....	7-4
	E. Corrosion Protection of Unpainted Towers.....	7-4
	F. Ladders and Safety Rails.....	7-5
	G. Application.....	7-5
	H. Records.....	7-5
CHAPTER 8.	TOWER ERECTION, ALIGNMENT, TWIST, AND GUY TENSIONS.....	8-1
	A. General.....	8-1
	B. General Tower Design Characteristics.....	8-1
	C. Analysis of Existing Towers.....	8-2
	D. Cause of Misalignment and Twist.....	8-2
	E. Alignment, Twist and Guy Tension Limitations.....	8-2
	F. Conditions for Alignment, Twist, and Tension Measurements..	8-3
	G. Determination of Alignment and Twist.....	8-4
	H. Guy Tensions.....	8-13
	I. Correction of Alignment and Guy Tension.....	8-19
	J. Frequency and Scope of Alignment and Tension Checks.....	8-20
CHAPTER 9.	TOWER LIGHTING AND LIGHTNING PROTECTION.....	9-1
	A. General.....	9-1
	B. FAA Notification Requirements for Tower Lighting Failures..	9-1
	C. Tower Lighting System Components.....	9-1
	D. New Lighting System Requirements.....	9-5
	E. Lighting System Inspection and Maintenance.....	9-5
	F. Lightning Protection.....	9-7
APPENDIX A.	GLOSSARY.....	1
APPENDIX B.	INSPECTION FORMS.....	1
APPENDIX C.	MANUFACTURER'S DATA FOR VARIOUS TOWER COMPONENTS.....	1
APPENDIX D.	LORAN BASE INSULATOR REPLACEMENT.....	1
APPENDIX E.	SPECIAL EVOLUTIONS FOR LORAN TOWERS.....	1

CHAPTER 1. INTRODUCTION

- A. Purpose and Scope. This Manual defines Coast Guard policy and criteria for the preservation of towers and prescribes minimum inspection and maintenance standards for use as a guide in organizing and managing a comprehensive tower inspection and maintenance program. The primary objectives of such a program are to keep critical antenna and navigation systems operational to the maximum possible extent, and to protect the Government's investment by economically maintaining the towers. This Manual shall be utilized for **all** Coast Guard towers to the maximum feasible extent. Towers are defined as any permanent structure that is more vertical than horizontal, that is energized or non-energized, guyed or free standing, and exceeds 20 feet in height. Tall towers are those 300ft in height or greater. Small towers are those less than 300ft in height. The safety requirements in Chapter Two of this Manual are applicable to all towers and elevated structures including monopoles, ATON structures, and communications support structures.
- B. Responsibilities. Commanding Officers of Civil Engineering Units are responsible for the establishment, administration, and direction of an inspection and maintenance program for the towers under their jurisdiction. To be effective, a sound inspection and maintenance program requires delegation of responsibilities and the full and continued support of all concerned. Therefore, a channel of clearly fixed responsibility for tower inspection and maintenance shall be established from the Civil Engineering Unit (CEU) to other commands in the field. Civil Engineering Units shall ensure, through directives, reports, etc., that the program is aggressively carried out at all levels in a systematic and thoroughly acceptable manner. Towers shall be periodically inspected by the various command levels to evaluate the sufficiency and consistency of the overall inspection and maintenance effort, and to verify attainment of the established standards of maintenance.
- C. Inspection and Maintenance Standards and Costs. Since differences in tower designs, materials, age, local environment, and previous maintenance are some of the factors of the inspection and maintenance program, standards shall be established by the servicing CEU within the latitude permitted by this Manual. These standards should be developed to permit timely detection and correction of deficiencies in order to preclude the necessity for major repairs or complete tower replacement. The frequency and extent of inspection and maintenance activities will be governed by the effort necessary to maintain the towers at the level of these standards. The effort to keep energized antenna tower off-air time to a minimum may necessitate increased costs for tower maintenance; a responsible trade-off must be made between cost and operating time. In general, CEUs should plan their inspections and maintenance of energized towers so that cost is a factor that is of less importance than off-air time. However, it is not intended that our structures be over-maintained at undue cost; judgment must be exercised at all times. In most cases, the final decision should be made by the servicing CEU, preferably within field budget limitations.
- D. Revision of Manual. This Manual will be updated periodically. Civil Engineering Units and other tower units are encouraged to provide the

Coast Guard Tower Program Coordination Center (CEU Oakland) with information copies of all tower-related reports, correspondence, and similar material which describe program improvements and practices of potential use to other commands. Field input remains the primary source of material for this Manual.

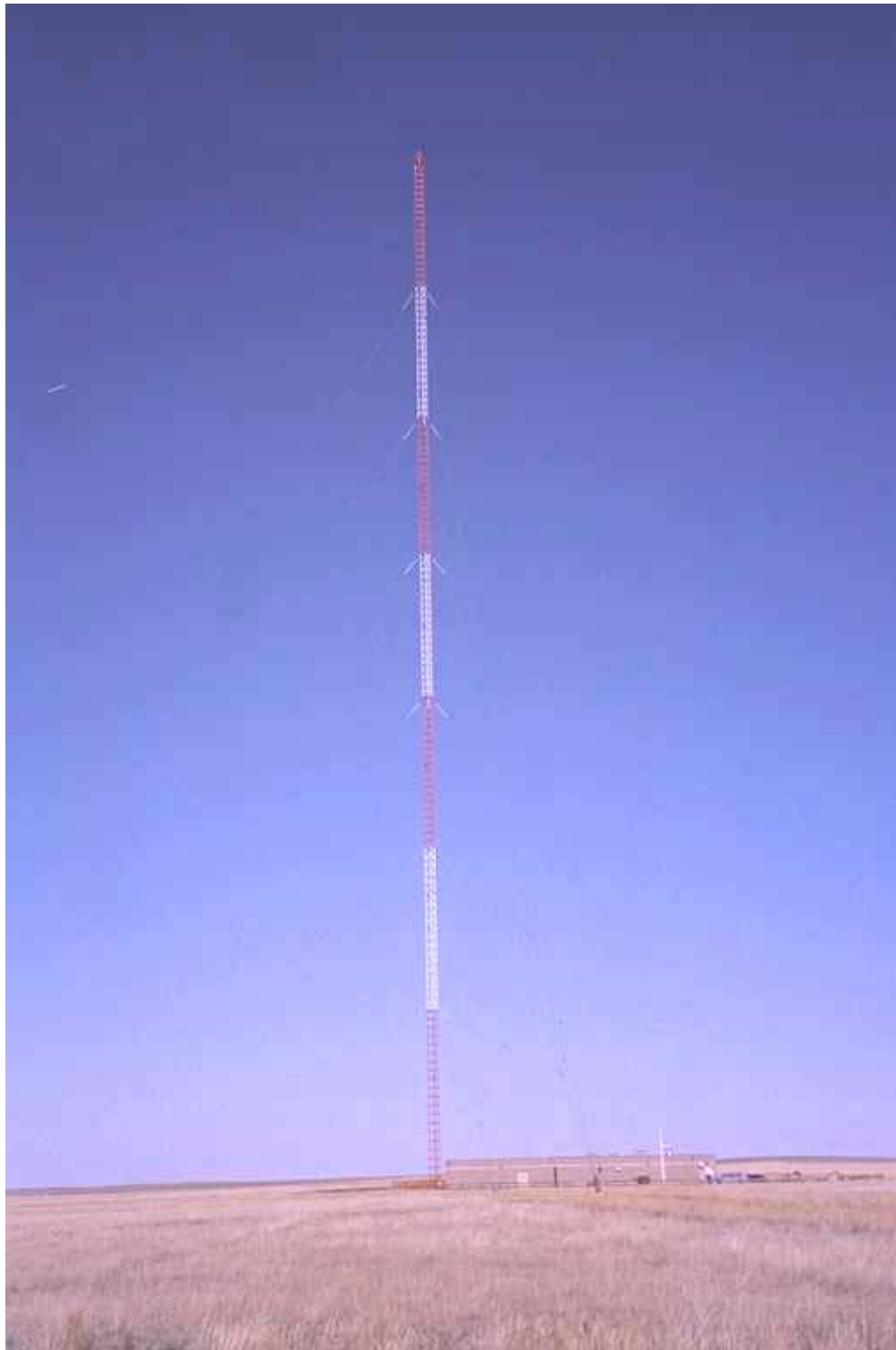

Figure 1-1 700ft energized Loran-C tower.



Figure 1-2 90ft Self supporting Vessel Traffic System tower.



Figure 1-3 Self supporting microwave tower.



Figure 1-4 60ft Self supporting communications tower.



Figure 1-5 Guyed rotatable antenna

CHAPTER 2. TOWER SAFETY

This chapter is divided into two sections; Part I is General Climbing Safety. Part II is General Tower Safety.

PART I. GENERAL CLIMBING SAFETY

- A. Safety Policy and Requirements. Safety is a primary consideration to which all Coast Guard personnel must devote their complete attention whenever they are climbing a tower or are in the immediate vicinity of a tower of any height. The elevation and potential electrical hazards associated with tower inspection, maintenance, and repair require adoption of extraordinary safety measures in order to protect the climbers from avoidable accidents. Towers are classified as elevated structures as defined by OSHA. *All personnel engaging in construction, maintenance, repair or inspection shall use fall protection when working on any Coast Guard tower.* Safety precautions also include the use of appropriate protective clothing to include the wearing of safety helmets, safety footwear, eye protection, and protective clothing to protect personnel from injury while in the vicinity of a tower. A safety helmet is required to be worn by any person within the tower drop zone, which is an area whose radius is 1/2 the height of the tower and centered on the tower axis. In addition, precautionary measures must be taken to protect the tower structure itself from damage.
- B. Buddy System. Climbers shall use the buddy system. When climbing to a height of 150ft or less a safety observer is required on the ground. The observer should be stationed a suitable distance away from the tower base, preferably upwind, so that he or she always has a clear view of the climber. The safety observer shall be a qualified climber who meets the requirements of ►D below. The safety observer shall be completely dressed with appropriate Personal Protective Equipment (PPE) including a Personal Fall Arrest System (PFAS) and a complete safety ladder climbing device. The safety observer shall have constant two-way communication with the climber on the tower. When climbing towers greater than 150ft in height the safety observer shall join the primary climber on the tower and stay within 150ft of the primary climber at all times.
- C. Climbing of Towers by Coast Guard Personnel. Coast Guard personnel must be authorized in writing to climb towers and elevated structures. This specifically includes all towers and elevated structures classified as Aids to Navigation. The servicing CEU has the authority to administer the Tower Climber Certification program for all units within its area of responsibility (AOR). At a minimum, the prospective climber shall have adequate knowledge of the following subjects:
1. Recognition and avoidance of dangers relating to encounters with harmful substances and animal, insect, or plant life.
 2. Use and inspection of personal fall-arrest equipment.
 3. Procedures to be followed in emergency situations.
 4. Rescue procedures.

5. First aid training including CPR - These requirements are not specifically taught in a tower qualification course. The tower program specifically relies on the PQS standards that require annual basic first aid. CPR training is highly recommended for all climbers.

D. Minimum Requirements. The following are the minimum requirements to qualify an individual to climb elevated structures.

1. The climber must be a responsible volunteer.
2. The climber must be physically qualified and physically capable.
3. The unit commander must recommend the climber.
4. The climber must complete climbing certification training, which includes a written test and a practical field test.
5. On the first climb the climber must be accompanied by a qualified Coast Guard military or civilian engineer who has been certified to instruct tower climbing and who is familiar with the safety requirements and hazards outlined in this Manual.
6. The climber shall be issued a written qualification letter from the servicing CEU. This letter will specify the maximum height of tower that the individual is authorized to climb and whether the individual is authorized to climb an energized or non-energized tower. This letter remains in effect as long as the climber remains within the AOR of the CEU that issued the letter.

E. Equipment. The equipment requirements are specifically referenced in OSHA 1926.502(d).

1. The climber must use a complete Personal Fall Arrest System, (PFAS), which consists at a minimum of a full body harness, deceleration lanyard(s), and connecting device(s). In addition when using a ladder for ascent or descent, the climber shall use a ladder safety climbing device, as shown in Figure 2-3. Climbers shall be physically connected to suitable anchorage on the structure at all times. See Part II ► D of this chapter, and Figures 2-1 and 2-2.



Figure 2-1 Existing Coast Guard Harnesses (front and rear view).



Figure 2-2 Typical commercial harness meeting ANSI requirements.

2. All Personal Protective Equipment used must meet the standards of 29 CFR 1926.502, Fall Protection System Criteria and Practices, Subpart M, Fall Protection.

- a. Personal Fall Arrest Systems consist at minimum of an anchorage, full body harness, deceleration lanyard and connecting device.
- (1) Anchorages are secure points of attachment for lifelines, lanyards or deceleration devices, and are independent from the means supporting the worker.
 - (2) Full body harness must meet ANSI Z359.1-1992 requirements and must have a "D" ring which is centered in the wearer's upper back. The harness must be sized to the individual. The full body harness must be specifically rated for fall arrest (see Figures 2-1 and 2-2).
 - (3) Connecting devices include deceleration lanyards, working lanyards and ladder safety climbing device. Shock absorbing fall restraint lanyards (also called deceleration lanyards) must meet ANSI Z359.1-1992 and ANSI A10.14-1991. These devices limit free-fall to 6 ft. The shock absorbing portion of the lanyard must be attached closest to the wearer's body. The overall length of the lanyard is limited to 6ft. Ropes, straps and webbing used in lanyards, lifelines and strength components of body harnesses shall be made from synthetic fibers.
- b. Connecting Hardware must have double-acting or 2-step safety locks. Shackles, clevis, carabiners, and hooks are the four common hardware connecting devices. All connecting hardware must have a minimum tensile strength of 5000 pounds and shall be proof tested to a minimum of 3600 pounds.

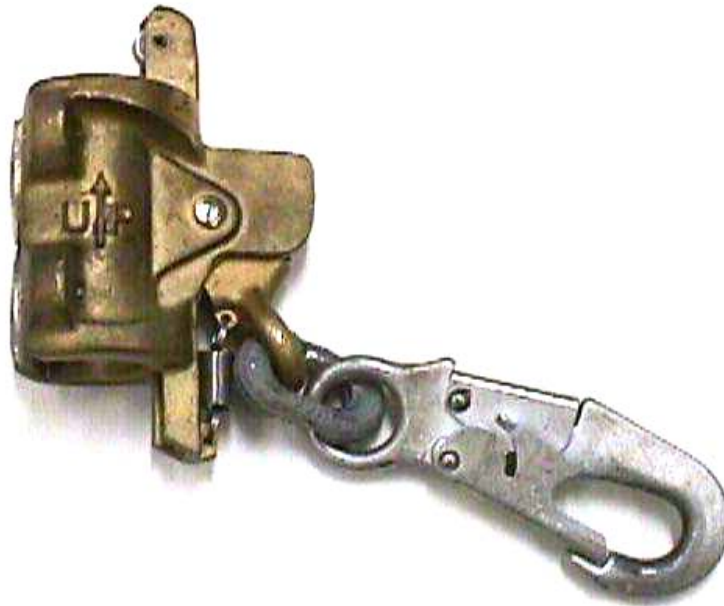

Figure 2-3 Typical ladder safety climbing device (Saf-T-Climb).

- c. No part of a personal fall arrest system shall be used for other than its intended purpose. Never use this equipment for hoisting or towing. Do not use this equipment for recreational climbing.
 - d. Understand, know and follow the maximum weight limits for your personal fall arrest safety equipment. These limits are stated in the manufacturer's instructions. The working load limit is equal to the combined person and tool weight. Generally, the working load limit for a full body harness is 310 pounds.
 - e. All equipment, lines and hardware shall be rated for use. Each piece of equipment shall be inspected for wear, damage, and other deterioration before each use, and defective components shall be immediately removed from service and destroyed.
- F. Pre-Climb Safety. Pre-mobilization planning; Prior to any work on an elevated structure the following shall be evaluated by the supervisor:
- 1. The skill and experience of each member of the crew assigned to perform the work.
 - 2. Any special equipment that will need to be acquired and any special training or training reviews that must be performed before work begins.
 - 3. The type of equipment that will be required and the individual worker's training and skill with that equipment.
 - 4. Any special fabrication required for safety before work begins.
 - 5. The emergency services available near the site and whether they could find the site in a timely manner. Question rescue services to establish that they have the equipment, skills and response time to rescue a climber in the expected environment. These services should be given directions to the site.
 - 6. The location of the nearest medical facilities. Every member of the crew should have access to a route map.
 - 7. The phone numbers of emergency facilities, accessible to all members of the crew. Work at remote locations will require use of cell phones or a means of positive communications.
 - 8. The familiarity of each climber regarding the location AND operation of any rescue equipment and location of a first aid kit.
 - 9. The tower should not be climbed in inclement weather, when electrical storm activity is forecast, or when fog obscures that portion of the tower to be climbed. In locations where fog is usually present and where unacceptable delays would result while waiting for the fog to dissipate, the tower may be climbed provided the climber and safety observer are equipped with reliable two-way radios. Radio checks should be initiated at least every 5 minutes.
 - 10. The tower shall be de-energized for mounting, climbing and dismounting, except as noted in parts II.B.1 and II.B.2 of this

chapter. A deadman stick shall be used to positively ground the tower.

11. A safety lanyard shall be attached to all tools and equipment on the tower to prevent missile hazards.
12. Site Safety Meeting - Upon arrival at the site, all climbers shall hold a pre-climb safety meeting. Ensure every climber knows where emergency equipment is stored and where emergency medical facilities are located. The length of these meetings is directly related to the complexity and type of work to be performed.
 - a. Hazard Assessment: Review all possible hazards to include:
 - (1) Weather related, such as wind, snow, ice, moisture, lightning and sunshine.
 - (2) Electrical dangers.
 - (3) Noise.
 - (4) Live hazards such as snakes, birds, insects, rodents, farm animals and other humans.
 - (5) Other conditions, including non-standard structure hazards.
 - b. Perform individual pre-climb inspections to include route inspection.

G. Conditioning and Mechanics of Climbing.

1. Personal condition is as important as the safety equipment. For safety, you will need physical well-being, emotional conditioning, a well-rested mind and body, self-confidence and freedom from drugs of any type. Get plenty of sleep and eat sensibly. Keep your fluid intake adequate. Never consume alcohol prior to or while climbing.
2. Ascending/Descending
 - a. Climbing is a physical process and requires practice to do it correctly. CLIMB WITH YOUR LEGS, AND NOT YOUR ARMS. Climbing is not a race. Your goal is to arrive at your work location comfortable, relaxed and ready to work.
 - b. No one should stand around the base of a tower while a person is ascending or descending or working.
 - c. Use of a safety climb device requires that you keep three points of contact with the structure. Do not jump or hop.
 - (1) Climb with your legs, not your arms.
 - (2) On tapered towers climb on the high side or side that allows the climber to naturally lean into the tower.
 - (3) Legs lead on the climb, arms lead on the descent.

- (4) Rest often and use rest platforms when they are available.
 - (5) Keep body swing to a minimum.
 - (6) Be well rested, confident and drug-free.
- d. Maneuvering- Climbing and maneuvering on communication towers uses body mechanics that predominately involves the use of the arms and legs. "Look before you leap". Before undertaking any physical maneuver, consider carefully what you are doing. When suspending or descending use approved descent equipment that is designed to control your descent mechanically, not physically. If you are in doubt as to how to reach a particular location on the structure or how to perform the task in a location, consult other team members and your supervisor. Consider different physical actions and select the one that best suits your skill, strength, condition and experience.
- e. Crossing and Positioning - Before exiting a safe climb device, you must determine the need for fall protection. You must be continually aware of the location of other climbers and their anchorage points. Pay particular attention to attaching to diagonal structures or members. Remember that the connector will slide down diagonal structures. During the cross to a work area you must maintain 100% fall protection, which generally means 100% connection to the structure. The 100% connection rule is as effective as your attitude. If you are tired or tense, stop and connect with your lanyard and rest. Climbers are exerting physical energy and can often become over fatigued. When you are tired, cold, hungry, cramped or distracted, you are not safe.
- f. Working on a Structure - Select a proper structure and wrap your positioning lanyard around the structure so it allows movement of your hands sufficient for the task. A rule of thumb is hold your elbow at your waist and move your arm up and down from chin to lap. If you do not contact the structure, the distance is correct. Be sure that the lanyard is connected and properly locked. NEVER TRUST THE SOUND OF THE HOOK OR CONNECTOR. Visually sight your hardware and ensure that it has closed and is locked. Do not attach safety lanyards to guard rails, hoists, platform gratings, lighting equipment or any loose equipment on the tower.
- H. Rescue. There are five generally accepted rescue techniques. Each of the below techniques requires specific training and equipment. These techniques must be practiced on a recurring basis and as such are considered an integral part of any tower training conducted.
- 1. Manual rescue: Reaching a fallen worker from the structure and pulling him back to the safety of the structure.
 - 2. Outside Services: Professional rescue services; These should be used when available and if the response time is adequate.
 - 3. Winch Rescue: If a winch is available and rigged, or can be rigged, attach an injured worker to the winch line and lower the victim to

the ground.

4. Ascending/Descending Systems: These are manually operated devices that are appropriate to many climbing environments and to one-rescuer operation.
5. Approved suspension systems: This is an approved descent and suspension device that can be used to reach a fallen climber and assist the climber to the ground.

Credit: Much of the information contained in Part I of this Chapter was taken directly from Tower Climbing Safety and Rescue, Second Edition, published by ComTrain, 1999.

PART II. GENERAL TOWER SAFETY

- A. Climbing of Towers by Contractor. Contractor personnel shall be bound by all applicable OSHA regulations whenever a tower is to be climbed and shall be familiar with the contents of this manual. In addition, whenever a tower is to be climbed the following conditions apply:
 1. The tower should not be climbed in inclement weather, when electrical storm activity is forecast, or when fog obscures that portion of the tower to be climbed.
 2. The tower shall be de-energized for mounting, climbing, and dismounting. Exceptions are noted in section B below.
- B. Work on Energized Towers. Only LORAN-C towers may be climbed while energized. NDGPS and DGPS shall not be climbed under any circumstances while energized. All personnel working on or near energized Loran-C towers should be familiar with Sections II and III of Appendix E. All personnel working on energized Loran-C towers shall be qualified climbers. Mounting and dismounting energized towers, and performing maintenance outside the cross-section of energized towers should be the exception rather than the rule. Work required on an energized LORAN-C the tower can be accomplished with a minimum of RF exposure, if the personnel remain within the tower structure and below the base of the top platform. When the work is required above the base of the platform, it is recommended that transmissions be secured as permissible exposure limit (PEL) is exceeded approximately one foot above the platform base. When work is to be accomplished within one foot of the feed point or feed wire run, the transmitter should be secured.
 1. Mounting and Dismounting. Loran-C towers may be mounted and dismounted without de-energizing the tower provided the procedures detailed in Appendix E are strictly followed, and when conditions exist that do not permit the use of momentary off-air time. When work is required while a LORAN-C tower is transmitting, it is recommended that the tower access ladder be set in place by personnel other than the actual tower climber. Upon ladder placement, personnel should exit the area. The tower climber should then enter the PEL area, climb the ladder and enter the tower as described in Appendix E.

2. Climbing Towers for Inspection, Painting, or Repair. Loran-C towers may be climbed while they are energized. When climbing energized Loran-C towers the following precautions should be taken:
 - a. The conditions of Part I.B or Part II.A of this chapter, as appropriate, shall be met.
 - b. Because of the inherent danger of RF exposure, climbers must remain inside the tower cross-section, extending hands and arms only as necessary to reach lighting fixtures or other accessible tower components, and extending the head only as necessary to take twist readings by the leg sight method (see Ch.8 ►G.2.a), or to visually inspect the outside faces of the tower. Exceptions to this precaution are detailed in Appendix E, and apply only to Loran-C towers not exceeding 1000 feet in height. For further information or clarification, see the Electronics Manual, COMDTINST M10550.25(series) or contact the CG Command and Control Engineering Center (C2CEN).
 - c. Climbers should avoid extending any part of the body beyond the corona shield/guard rail at the top of the tower.
- C. Maintenance of Energized Towers. Maintenance of Loran-C towers that can be performed with the maintenance personnel inside the tower cross-section may be performed while the tower is energized provided the provisions of Part II.B above are complied with. Tower maintenance outside the tower cross-section and on the guy cables and insulators should be done during periods of off-air time. Requesting off-air time is an inherent part of scheduled recurring maintenance. It is the preferred method for performing maintenance. Maintenance efforts that require someone to be outside the tower cross-section may be performed on energized Loran-C towers provided the provisions of Appendix E are complied with and circumstances prevent the use of off-air time to perform the maintenance.
- D. Ladders and Safety Climbing Devices. It is Coast Guard policy to conform to the Occupational Safety and Health Administration (OSHA) Standards with respect to ladders and fall protection. The following requirements reflect the latest interpretation and adaptation of these standards for Coast Guard towers:
 1. All new towers shall be constructed with a fixed ladder equipped with a ladder safety climbing device. Rigid rail safety climbing systems which meet Federal Specification RR-S-001301 Type I are required. The Saf-T-Climb system, manufactured by North Safety Products (<http://www.northsafety.com/>) is the preferred rigid rail climbing system. Existing towers that do not have fixed ladders shall, if practical, have ladders with ladder safety climb devices installed under the AFC-43 maintenance program.
 2. All towers shall have a reasonable and safe means of ascending and descending the structure. Loran-C, radar antenna support, and similar tall towers should be equipped with fixed metal ladders conforming to OSHA Standards 29CFR1910.27, "Fixed Ladders", Subpart D and 1926.1053, Ladders, Subpart X. Even though the use of ladders is not considered mandatory by OSHA, the use of ladders remains the most practical and safe means of climbing towers. Towers, monopoles, and

all elevated structures shall have a safety climb system installed to the extent it is possible and feasible. When the configuration of the structure will not allow installation of a ladder with safety climb system, alternative methods of providing fixed anchorage to ensure climbers' safety is required. When modification to a tower to include a heavy metal ladder is not structurally feasible or economically justified, the original design is acceptable provided a safety climbing system as described in ►D.1. above is installed.

3. Poles or similar non-lattice type structures which are not equipped with authorized safety climbing devices and/or an adequate ladder or climbing surface must be climbed only by contractor personnel or by specially trained Coast Guard personnel.

E. Protective Barriers and Warning Signs. To protect the towers and anchors from vehicular damage as well as to guard against injuries to personnel, the following protective barriers and warning markers shall be provided:

1. A permanent, single gated fence, constructed of non-conductive material shall be installed to completely enclose the immediate area around the base of each transmitting antenna tower. "High Voltage" warning signs should be conspicuously placed on the outside face of each side of the fence and on the gate. The gate should be padlocked at all times, except when authorized personnel are within the enclosure or are on the tower.
2. Where access roadways are located under low-hanging guys, warning signs that provide the clearance in feet and meters should be installed on the lowest guy. Where perimeter fencing for an entire antenna field or station is not provided, and where the public can gain unrestricted access to the guy anchors, consideration should be given to enclosing each anchor by a fence with a lockable gate. Anchors not so enclosed should be marked in one of the following ways:
 - a. Prominently placed wooden posts painted in alternating yellow and black stripes to alert pedestrian and vehicular traffic. The posts should be nominal 4"x4" in section, and should extend at least 4 feet (1.2m) above ground level. The placement and number of posts should be such that traffic is directed around the anchors and away from the guys.
 - b. If the anchor concrete or steel is prominent and not liable to be covered with vegetation, these anchor components may be painted in alternating yellow and black stripes to alert traffic.
 - c. Retroreflective, brightly colored reflective guy guards, such as those manufactured by the Preformed Line Products Co., may be installed on the lower portion of the guys.

CHAPTER 3. INSPECTION GUIDELINES

- A. General. Sources of technical and historical information on each tower and guidelines and responsibilities for inspection and maintenance are covered in this chapter.
1. Tower Manuals and Drawings. An erection manual, erection and fabrication drawings, and, in some cases, maintenance manuals are furnished with each tower. These materials are the only source of specific data on the various components of each tower, and they should always be readily available to personnel charged with tower inspection and maintenance responsibilities. As tower modifications are made, the drawings and manuals should be annotated with the date and description of the modifications. The information contained in this Manual does not duplicate the information contained in the tower manuals and drawings furnished with each tower. Operational and support commanders shall forward to the servicing Civil Engineering Unit (CEU) and the Tall Tower Coordination Center updated drawings whenever towers or antenna systems are modified.
 2. Inspection and Maintenance Records. The servicing CEU should maintain a complete file for each tower or antenna system containing:
 - a. Inspection reports.
 - b. Specifications used for inspection or maintenance.
 - c. Correspondence pertaining to the particular tower or antenna.
 - d. Records of all maintenance or modifications.
 - e. Updated inventory of tower spare parts.
 - f. Pertinent procurement documents.
- B. Inspection Categories.
1. Tall Tower Coordination Center (TTCC) Level. This category of responsibility includes policy development, technical assistance to support CEUs, MLCs and other units involved with the tower program. Periodic tower inspections may also be conducted by TTCC personnel. Except in an emergency, the TTCC should also be invited to review proposals for repair, modification, or replacement of major tall tower system components. "Major components" are tower guys, anchors, legs, horizontals, diagonals, foundations, and insulators.
 2. Major Field Command Level. This is the primary level of responsibility and rests with the CEU. Responsibilities at this level include:
 - a. The administration and planning for all inspection and maintenance activities.

- b. Providing technical assistance, contract services, materials, and equipment as may be required to perform inspection and maintenance activities.
 - c. Determination of inspection frequency as well as training and designation of inspectors.
 - d. Determining which inspection and parts maintenance items are to be performed by station and field personnel; and training the station and field personnel to accomplish these tasks.
 - e. Determining major maintenance requirements, and seeking approval for repair, modification, and/or replacement of major tower system components (see B.1 above).
3. Intermediate Level. This intermediate level of responsibility, if established, will consist of such responsibilities outlined in ►B.2 above as may be delegated by the CEU. Typically ESUs, Groups and some elements of MLC staff fall into this category depending on the tower function.
 4. Unit/Field Level. Through years of experience, it has been determined that unit and field personnel must play a very important role in the inspection and maintenance program. A large number of Coast Guard units with towers are located in remote areas, and the attentive and properly trained eyes of field personnel are therefore essential tools of the servicing CEU. In addition to certain routine inspection responsibilities such as noted in ►C.3.a below, the field unit or station shall conduct a visual check of tower alignment (see Ch.8 ►G.) and the general tower condition (from the ground) following each heavy storm, earthquake, or icing condition (see Fig. 3-1).
- C. Inspection Objectives and Requirements. Inspection on a periodic basis is the most effective way to protect the Coast Guard's investment in towers. Major field commanders should consider it their first priority, where the antenna system is concerned, to establish a sound inspection program utilizing all of the expertise available. In this way it will be possible to provide for the timely detection and correction of deficiencies before major tower maintenance or repair become necessary. With early detection and correction, both costs and off-air time will be minimized.
1. Inspection Frequency and Effort. Because of seasonal storm cycles, antenna systems should be carefully inspected about once per year, making allowances for local conditions, expenses involved, expertise availability, and the magnitude of the original capital investment. The quality of an inspection is only as good as the personnel performing the inspection. Almost complete reliance is placed on visual inspection methods. The ability of the inspector to detect potentially hazardous conditions and to recognize serious defects is of paramount importance. A hurried or superficial inspection cannot produce the desired result, regardless of the ability of the inspector. Inspectors should be guided by detailed information contained in this Manual.

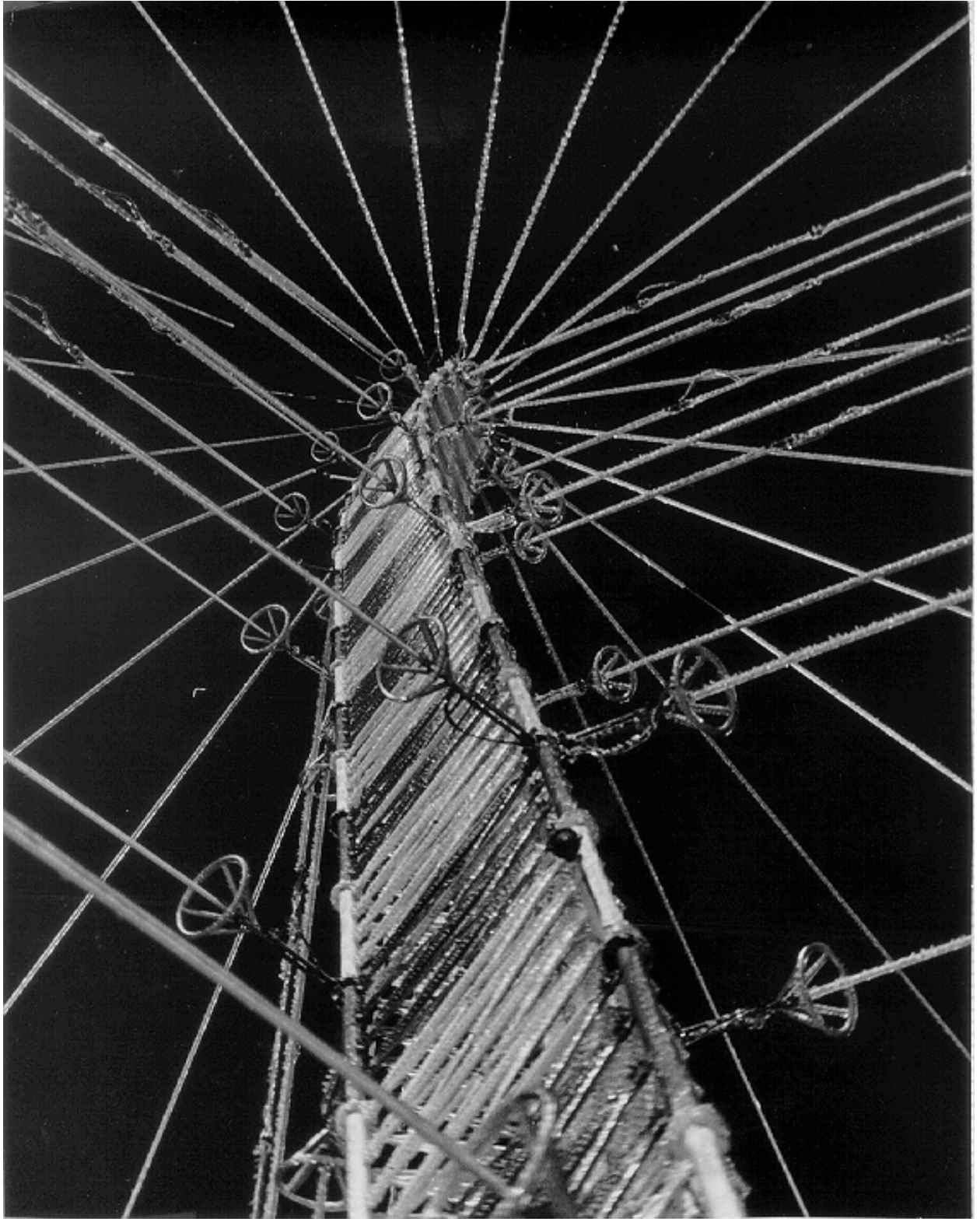

Figure 3-1 625 ft Tower deflected due to heavy icing conditions.

2. Contract Inspections. Because contracting for inspection services is usually expensive, efforts should be made to maintain an in-house inspection capability. However, there are several major tower inspection, manufacturing and erection firms providing these services. In either case, it should be recognized that the capabilities of the personnel offered by these firms can vary considerably, and the inspection results will follow suit. Whenever doubt exists as to individual capabilities, a thorough investigation should precede selection of a particular contractor. CEUs should develop lists of qualified firms.
 - a. Scope and Scheduling. To gain maximum benefits from contract inspections, the scope of the inspection work should be clearly and concisely defined and the inspection period should take full consideration of weather conditions. Inspection items that cannot be satisfactorily performed by Coast Guard personnel should be included in the scope of work of inspection contracts.
 - b. Analysis and Evaluation. A Coast Guard representative should be assigned to accompany the contract inspector. The representative should have a technical background such that he may make reasonable independent evaluations of the contractor's inspection technique and recommendations. In every case, the findings and recommendations of a contract inspector should be thoroughly reviewed and analyzed in order to preclude unconditional acceptance of his work. It may be necessary to inspect again or to test components before a course of action should be planned.
3. Coast Guard Inspections. Most tower inspections can be adequately performed by Coast Guard personnel familiar with general maintenance requirements and practices. By accepting a substantial portion of the inspection burden, the Coast Guard will produce a more effective and less costly inspection and maintenance program. In-house expertise is the best kind. All CEUs should concentrate on building this expertise through training programs and the experience of their staff personnel. Expertise known to be available in the staffs of various field commands should be utilized by other commanders to the maximum extent mutually acceptable.
 - a. Inspection by Station Personnel. Considering their full time availability, station personnel should be used to the maximum possible extent for ground level tower inspections. Station personnel should not be required to perform routine inspections on towers; however, they should not be prohibited from climbing towers for non-routine maintenance (see Ch.4 ►A.3). During visits to units, Coast Guard civil engineers and tower specialists should take time to tour the tower site with the station commanding officer and selected crew members in order to point out and explain the various items to be checked in a unit inspection. Such items include but are not limited to:
 - (1) Corrosion at particularly susceptible locations, including guy pull-offs, bonding straps, leg flanges, anchor arms and any tower metal in contact with soil or water.
 - (2) *Damaged or missing cotter pins.

- (3) *Slipped or unraveled guy-grip dead ends. (See Ch. 6 ►H.3)
- (4) *Crossed guys in a face-guyed tower.
- (5) *Chipped, cocked, or missing insulators.
- (6) Operation of the lighting system. (See Ch. 9 ►E.)
- (7) *Missing or inadequate safety wire on turnbuckles. (Ch. 6 ►I.2.)
- (8) Cracked or shifted concrete.
- (9) *Evidence of arcing on the guys or at the tower base.
- (10) *Position of lightning ball gaps (Ch. 9 ►F).
- (11) Damage to the ground radial system or grounding straps.
- (12) *Damage to or oil loss from the base insulator.
- (13) *Failed fiberglass rod insulators. (Ch. 6 ►J.2)
- (14) Safety requirements. (See Chapter 2)

* - Guyed towers only

- b. Inspection by Other Field Personnel. The majority of Coast Guard towers are located in remote or unmanned locations and are visited by contractors and technicians from intermediate level units. CEUs should take advantage of these scheduled visits for inspection of these unmanned tower sites. The intermediate level personnel should be trained by CEUs to check basic inspection items outlined in ►a.(1)-(14) above.
- c. Inspection Routine for Manned Tower Sites. The following general inspection routine is recommended for station personnel at manned tower sites. CEUs should provide unit level commanding officers with a more detailed routine, based on local considerations.
 - (1) DAILY - Visually check the lights after sunset unless monitored by an automatic failure alarm system.
 - (2) WEEKLY - Visually check all guy assemblies and tower structural members from two or more good vantage points on the ground. For energized towers, check for visible or audible corona or arcing on any antenna system components.
 - (3) MONTHLY - Visually check each anchor and the tower for abnormal conditions (see ►C.3.a above). Visually check tower alignment in accordance with Ch.8 ►G.1.a.
 - (4) ANNUAL - CEU and or contracted tower inspection for tall towers.

- (5) TRIENNIAL - CEU and or contracted tower inspection for small towers.
- d. Inspection Routine for Unmanned Tower Sites. The following general inspection routine is recommended for unmanned tower sites. CEUs should provide field and support commands with a more detailed routine, based on local considerations. CEUs and other support commands should work closely to ensure unmanned sites receive proper preventative maintenance and inspection.
 - (1) Preventative Maintenance Visits - Coast Guard personnel visiting unmanned sites for routine preventative maintenance should conduct the following using the small tower report (format 1) in Appendix B as a guideline. Visually check the lights in all modes of operation. Visually check all guy assembly (where present) and all tower structural members from two or more vantage points on the ground. For energized towers, check for visible or audible corona or arcing on any antenna system components. Visually check each anchor and the tower for abnormal conditions. (see ►C.3.a above). Visually check tower alignment in accordance with Ch.8 ►G.1.a.
 - (2) ANNUAL - CEU and or contracted tower inspection for tall towers.
 - (3) TRIENNIAL - CEU and or contracted tower inspection for small towers.
- e. Inspection by Coast Guard Civil Engineer or Coast Guard Staff Tower Engineer. The CEU Commanding Officer should ensure that one or more members of the CEU staff is fully qualified to perform tower inspections, including climbing of energized towers where necessary and authorized (Ch.2 Part II.B.1). Selected station personnel should accompany the inspector during the entire inspection, to assist and to learn. In addition to the items listed in ►C.3.a above, inspections by these staff members should include the following:
 - (1) Measurement of alignment and twist.
 - (2) Measurement of guy tension where feasible.
 - (3) Inspection of the lighting system, and relamping.
 - (4) On-tower inspection for corrosion, paint condition, damaged members, loose bolts, missing or damaged hardware, ladder and safety rail condition, etc.
- 4. Inspection Reports. A simple procedure for reporting station level inspections should be established by the servicing CEU, whereby only exceptions to the norm are reported (see format 1 of Appendix B). However, reports of inspections by Coast Guard civil engineers, tower specialists, and contractors should be as detailed as possible; they should contain, as appropriate, plots of alignment and twist, guy tension readings, accurate descriptions of discrepancies and their location, and good color photographs (see format 2 of Appendix B).

Simplicity, brevity, and substance should be the attributes of the narrative portions of inspection reports. Maximum use should be made of color photographs to show normal, typical, and unusual conditions. Copies of reports showing unusual conditions or procedures should be forwarded to other field commands that are responsible for similar towers.

D. Tower Failures.

1. Past Failures and Causes. Major tower failures have occurred over the years, providing a number of "lessons learned" which are reflected by certain sections of this Manual and in current procurement specifications. These failures and their causes are:
 - a. LORSTA Carolina Beach - 1961 - A self-supporting 625-ft tower buckled at 2/3 its height in a storm. Top-loaded radials had been added to a tower originally designed for no radials, and their presence overloaded the tower.
 - b. LORSTA Ejde - 1962 - A structural guy slipped through cable clips securing the guy at the anchor end, resulting in the collapse of a 625-ft tower.
 - c. LORSTA Iwo Jima - 1964 - A threaded eyebolt in a TLE insulator failed, causing swing-in damage to tower members. During the subsequent repair operation, the 1350-ft tower collapsed with workmen aboard. The apparent cause of failure was the lack of proper temporary bracing.
 - d. LORSTA Yap - 1964 - An error in procedure during erection caused the collapse of a partially erected 1000-ft tower.
 - e. LORSTA Angissoq - 1964 - Fatigue failure of the eyebolt head in a compression cone insulator on a structural guy caused the collapse of the 1350-ft tower.
 - f. LORSTA Jan Mayen - 1980 - Improperly installed tensions in combination with a heavy ice loading apparently caused this 625-ft Stainless Model 1300 tower to collapse.
 - g. COMMSTA Miami - 1992 - Two 300-ft guyed communications towers collapsed during Hurricane Andrew. The weak link appeared to be the fiberglass-rod insulators that connected the guys to the tower. Designed to function as axial-force members, these insulators may have failed prematurely when forced into bending due to twisting of the tower under the extreme wind load (see Figure 3-2a). Had each insulator been attached to the tower using a shackle as shown in Figure 3-2b, the collapse of these structures might have been prevented.
 - h. LORSTA Cape Race - 1993 - A fatigue failure of an eyebolt head occurred in a compression cone insulator (see Figure 3-3). The remaining insulators on the severed structural guy caused sufficient swing-in damage to the tower to collapse the structure. The insulators on this tower incorporated a rocker assembly that was designed to alleviate the cyclic bending stresses on eyebolt heads that contributed to the Angissoq

collapse of 1964 and failures of other non-Coast Guard towers. While it is evident that the universal-ring assembly has significantly reduced fatigue loading, this incident demonstrates the continued susceptibility of eyebolt heads to fatigue failure.

- i. LORSTA Kargaburun - 1993 - This 625-ft Stainless Model 1100 tower, which was inadequately designed for snow and ice loading, collapsed during a significant snowstorm. Because of faulty construction practices, the tower was erected with a built-in twist of 3.0 degrees, exceeding the 1/2-degree design parameter and further reducing the tower's load capacity. In addition, the TLE and structural guy foundation placement did not compensate for the slope of the site, causing the horizontal guy forces on the tower to be unbalanced. This may have further compromised the stability characteristics of the tower.
2. Documentation of a Tower Collapse. Although there is every hope that sound inspection and maintenance programs will preclude future tower collapses, the following steps should be taken if a collapse occurs:
 - a. Notify the servicing Civil Engineering Unit and the CG Tall Tower Coordination Center by message.
 - b. Mark each and every component as to its location in the antenna system.
 - c. Photograph all fractured components; mark all photos with identification of component, date, and name of photographer.
 - d. If feasible, take aerial photos of the collapsed tower from many angles; mark all photos as in (3) above.
 - e. Make an accurate plan view diagram of the antenna in its collapsed position, showing all components as accurately as possible.
 - f. Dispose of all rubble as directed by the servicing CEU. If any component is removed from the station for further examination, ensure that it is not later misplaced. If it is to be destructively tested, ensure that its "as received" condition is adequately photographed and described.
 - g. Ensure that certified copies of all documents are filed in at least three different cognizant offices.

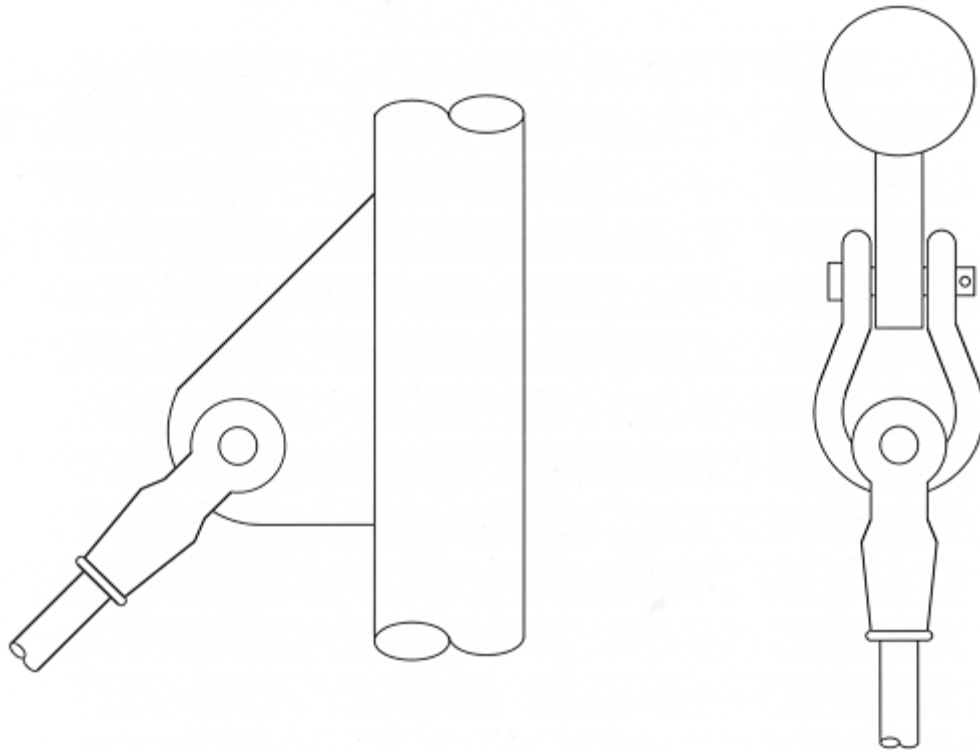

a. Elevation view showing insulator connected directly to gusset plate. Twisting of the tower could subject insulator to bending loads.

b. Plan view showing insulator connected to gusset plate via a shackle creating a universal joint to alleviate bending.

Figure 3-2 Connecting Insulator Rods to Avoid Bending Loads.

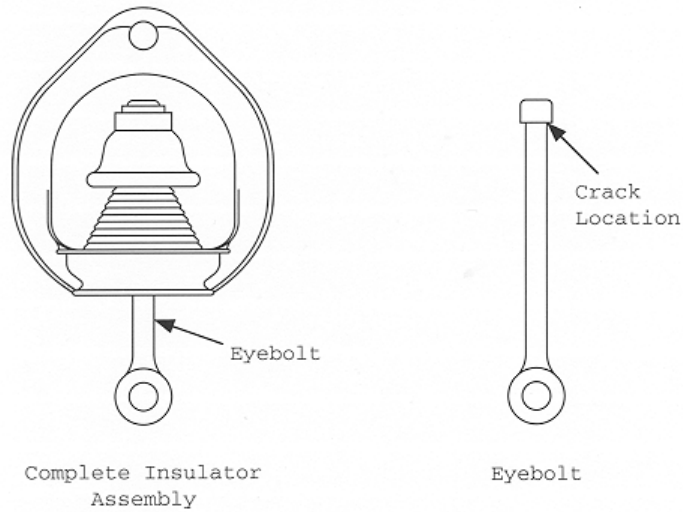

Figure 3-3 Location of fatigue failure in compression cone insulator.

CHAPTER 4. MAINTENANCE GUIDELINES

- A. Maintenance Objectives and Requirements. The primary purpose of maintenance is to correct deficiencies in the early stages so that they will not cause unnecessary off-air time or develop into costly repair projects.
1. Maintenance Effort. The quality of tower maintenance is only as good as the personnel, methods, and materials employed in the work. Proper selection of these elements is a prerequisite to satisfactory maintenance. Major forms of maintenance or repair, which require slacking or removal of guys, structural component and insulator replacements, heavy lifts, etc., should normally be accomplished by contractor personnel. Coast Guard personnel should perform substantial ground level component preventative maintenance and emergency on-tower repairs to the maximum extent possible.
 2. Contract Maintenance. Whenever the scope of required tower maintenance dictates that the work be done by a commercial contractor, only qualified tower erection or maintenance firms should be considered. A firm may be considered "qualified" if it employs key personnel (foreman, winch operators, riggers) who have had recent successful experience in maintaining towers of similar height, and which owns or has access to proper equipment necessary for the job. Depending on the complexity of the tower maintenance a professional engineer may need to be specified. Pre-award surveys should be conducted, considering factors such as job supervision, percentage of work subcontracted, method of accomplishing the work, potential to minimize off-air time, and quality of manpower. Specifications should include incentive and/or liquidated damages clauses as appropriate. They should carefully spell out the available government assistance, such as station personnel, lodging, messing, transportation, tools, shop spaces, and other items which will clarify the situation for bidders and which will tend to reduce costs.
 - a. Scope, Scheduling, and Approval. Tower inspection reports should be the source of the scope of work for most tower maintenance contracts. Minor maintenance items such as lighting system repairs, treatment of localized on-tower corrosion, etc. may be included within the scope of a contract inspection if no major maintenance is required. Work should be scheduled to take advantage of optimum weather conditions and to minimize off-air time. The servicing CEU should inform the Tall Tower Coordination Center if conducting the following maintenance:
 - (1) Replacement or installation of any structural tower member, including guy system components;
 - (2) The slackening or removal of any structural or radial guy;
 - (3) Replacement or installation of any component of the tower lighting system, except for replacement in kind; or

- (4) Any modification to the grounding or lightning protection system.
- b. Review of Contractor's Plans. Whenever contract work calls for slackening or removal of a structural guy or replacement of any tower structural member, the specifications shall call for a prior engineering review of the contractor's proposed procedures. The shop drawings clause of FAR 52.236-21 should be used when requiring submission of proposed rigging methods. See ► C.4 and ► E below.
- c. Insurance. Because of the high risk involved in working on primary members or structural guys of these non-redundant structures, insurance may be required when justifiable in accordance with FAR 52.228-5. When insurance is to be required, the contract file shall cite specific reasons for inclusion of the provision, in sufficient detail to clearly establish that the insurance is in the best interest of the government. The value of such insurance shall be sufficient to include the cost of repair and/or replacement of all government property which might be damaged in a singular, massive tower collapse which could occur due to improper performance of the work or associated activities. This value shall be established in the invitation for bid (IFB). However, the contractor should not be required to list the cost of insurance separately in the bid. Insurance should be considered for initial tower erection, whenever replacing a primary tower shaft member and whenever a non-redundant structural guy is disconnected from the tower or its anchor.
- d. CG Inspector. A Coast Guard representative should be assigned to all tower maintenance, repair, or modification contracts as an inspector on a full-time basis whenever feasible. The representative should have a technical background such that reasonable, independent evaluations of the contractor's methods may be made, and to ensure that the work is accomplished in accordance with the contract. If feasible it may be desirable to employ the services of a contract inspector or tower consultant when the degree or magnitude of tower work exceeds the capabilities of available Coast Guard personnel. For minor work, the station commanding officer may be delegated the responsibilities of the contracting officer's representative.
3. Coast Guard Maintenance. Maintenance should be performed by Coast Guard personnel to the maximum possible extent. Personnel familiar with general equipment and electrical maintenance and repair practices should be able to satisfactorily accomplish a substantial portion of the preventive maintenance effort. This will greatly reduce the costs of tower maintenance. Coast Guard station personnel should be utilized as much as possible for preventive maintenance.
- a. Maintenance by Station Personnel. Civil Engineering Units shall promulgate lists of maintenance items for which the station commanding officer is responsible. Repair of extinguished lights is the only on-tower maintenance normally required of station personnel. Except in extraordinary circumstances, this

maintenance should be at the ground level only, including such items as:

- (1) Treatment of corrosion and corrosion control.
- (2) Repair of the ground system.
- (3) Repairs to the lighting system.
- (4) Installation of safety wire at anchors.
- (5) Renewal of non-structural components, such as cotter keys.
- (6) Cleaning of insulators.
- (7) Adjustment of ball gaps.
- (8) Clearing of vegetation around the guy anchors and tower base.

b. Maintenance by Civil Engineering Units. In-house maintenance capabilities vary widely throughout the Coast Guard. Types of maintenance to be accomplished or supervised by personnel at this level is best left to the discretion of the servicing CEU. At a minimum, the CEU Commanding Officer should ensure that members of his staff periodically inspect all maintenance performed by station personnel, and that station personnel are trained in proper methods.

B. Maintenance, Repair, and Modification. While an adequate tower maintenance program will lengthen useful tower life, it cannot be expected to entirely eliminate the eventual requirement for repair or replacement due to damage, premature failures, or normal wear.

1. Replacement Materials. Materials and equipment used for repairs or replacements will be of the same size and type as used in the original design. Higher quality replacement materials which would provide longer life may be substituted for the original materials provided there is long-term economic justification.
2. Timely Corrective Repairs. The maintenance program should not only be concerned with maintenance and repair of superficial failures or damage, but with the timely correction of the basic cause of failure. Some damage may be due to normal wear and weathering, but many failures may be traced to other causes. Correction of these underlying causes will be justified by decreased maintenance as well as improved tower longevity and safety.

a. Causes of Failure. Premature failures of tower structural components, materials, and other parts may be caused by one or more of the following:

- (1) Lack of proper maintenance.
- (2) Defective materials or parts.

- (3) Incorrect installation or application.
 - (4) Failure of related, connected, or adjacent components.
 - (5) Unusual or extreme climatic conditions exceeding design considerations.
 - (6) Faulty design.
 - (7) Damage done during construction or maintenance activities.
- b. Investigation and Reporting of Failures. Component failures should be carefully investigated and the basic defects corrected before superficial repairs are accomplished. Prompt reporting of failures to higher command authority should immediately follow detection so that preventive measures can be taken on similar towers. Major component failures should be reported to Commandant (G-SEC) and the Tall Tower Coordination Center with a detailed description of the circumstances and conclusions as to the cause of the failure.
- c. Technical Assistance. Unless the cause of a particular failure is immediately discernable and corrective measures are not complicated, a higher command level should be consulted for advice on corrective action.
- d. Tower Designer's Instructions. In the case of some specific materials and equipment, the tower erection and maintenance manual and/or original drawings may provide sufficient information for corrective measures.
- e. Tower Design Consultants. In vital structural matters or in complex circumstances, consultation with qualified tower design engineers may be necessary. If still available, the tower manufacturer is normally a good source of information on design questions.
3. Modifications. Any tower modification should be evaluated by a structural engineer with specific knowledge in tower design and construction. Additions of any antennas or appurtenances, beyond those contemplated in the original tower design, must be evaluated by a structural engineer. Specifically, requests from other government agencies and commercial companies to place communications equipment on CG property must comply with the application criteria as outlined by MLC(t). If available, the tower manufacturer is an excellent source of information. Proposed tower modifications such as communication dishes, antennas, or a change to the structural components must consider the types and compatibility of materials. Modifications which will not economically extend tower life or reduce the maintenance effort should be avoided. Modifications to towers of any height will be reviewed by Tall Tower Coordination Center upon request.
- C. General Inspection and Maintenance Problems. Some components are readily accessible and can be checked visually without difficulty. Others are either inaccessible or hidden, making inspection difficult. Visually

detectable deficiencies should not present any inspection problem, but hidden or latent defects are of great concern.

1. Accessible Tower Components. The entire tower structure, ground level components, and guys, radials, guy insulators, and hardware in near proximity to the tower and anchors are readily accessible for close visual inspection. Consequently, it is very unusual for visually detectable deficiencies in these areas to develop into major structural problems.
2. Inaccessible and Hidden Components. The major portions of the tower guys, radials, guy insulators, and hardware are not easily accessible and in most cases the major portions of the tower base foundations, anchors and anchor arms are hidden by ground cover. Regardless of the inspection difficulties, the timely detection of deficiencies in these areas is just as important to tower preservation as those in the more accessible areas. In order to provide a means for the visual detection of tower deficiencies and abnormalities on inaccessible and hidden tower structural elements, several practical inspection methods may be employed. For inaccessible areas, these methods are: binocular or telescope examination, disconnection of guys at their anchor points for examination from the ground and the tower, and riding the guys; for subsurface areas, excavation of the overburden is required.
3. Binocular/Telescope Inspection. This method cannot be expected to produce the same results as a close visual examination, but it can reveal conditions such as frayed guy cables, broken guy components, contaminated insulators, evidence of corrosion, and similar physical abnormalities. Observing the tower guys and associated insulators and hardware from the ground and from the tower will substantially increase the scope of visual inspections. Some units have been furnished high-powered Questar telescopes to facilitate detailed inspection from the ground. A special camera provided with the Questar enables inspectors to photograph discrepancies for the record. Use of other types of telescopes and binoculars is acceptable. The use of this device is encouraged during inspections by Coast Guard personnel.
4. Disconnection of Guys for Inspection and Maintenance. This provides a means for conducting a close visual inspection of the guy system on any tower regardless of height. It is practical for towers up to 700 feet in height, but is a most difficult and arduous task when applied to towers in the 1000+ ft. range. Guys should be disconnected only for urgent structural reasons, and then only by experienced and qualified personnel. See ► A.2 above.
 - a. Lowering Structural Guys. Whenever a structural guy is slackened to be walked in toward the tower or to be lowered completely to the ground, a temporary guy must first be installed and the full load transferred to this temporary guy. At the tower end, the temporary guy is usually attached to the tower leg just above the permanent guy pull-off. At the anchor end, the temporary guy is usually attached to a come-along or suitable winching device, which is in turn connected to a spare connection point on or adjacent to the anchor. This procedure is discussed in Evolution #6 of Appendix E.

- b. Maintenance of Structural Guy Anchor Hardware. One of the most common reasons for disconnecting structural guys from their anchors is for the maintenance or replacement of anchor-end turnbuckles or thimbles, or to reposition the anchor-end Big-Grip dead ends (always using new ones) to allow turnbuckle adjustment. A come-along, winch, or other suitable pulling device, properly attached to the existing guy far enough up the guy to allow the work to be accomplished, and properly connected to a pulling point adjacent to the existing connection is considered to be an adequate temporary guy for the performance of this type of work.
 - c. Radial Guys. When a radial guy is slackened, temporary guying is not required. However, the opposing radial should be slackened in order to minimize deflection at the tower top. For 625-ft and 700-ft. Loran-C towers, procedures in Appendix E should be followed, modified as necessary when the tower is de-energized.
5. Riding the Guys. This inspection method is only preferred for guy and insulator inspections on towers greater than 1000ft in height before disconnection of the guys is considered. A bosun's chair or other device is rigged, and the inspector "rides the guy", or next to the guy, to the ground while examining all of the guy components. While this method requires special skill and rigging, it does not subject the tower to the risks inherent when a structural guy is disconnected. Appendix E describes several methods. Specifications for inspection by guy riding should be the "performance" type. Actual contract documents should not incorporate procedures shown in Appendix E, but the contractor may be allowed access to this appendix.
6. Subsurface Inspections. The most important subsurface structural element to be inspected is that portion of the steel anchor arm that is in contact with the soil. However, it may be desirable to expose the concrete portions of an anchor to check for deterioration. In either case, careful excavation is necessary. This excavation should be done only on one anchor at a time, and the excavation should always be backfilled with properly compacted material before another excavation is attempted. Up to two radial anchors of a 625-ft or 700-ft tower may be uncovered at a time provided they are opposing anchors and both are exposed and the radial guy is slackened in each case. Excavations should be restricted to the sides and backs of anchors as much as possible, or to the immediate local area around the protrusion of the anchor arm. Excavations should be done when winds are as calm as possible and high winds are not forecast for the work period.



Figure 4-1 Excavation and inspection around anchor arm.

7. Corrosion from Within. The structural members of many towers are thick-walled tubes that are crimped at the ends and then drilled to provide connection holes. Tiny "drain holes" in the bottom or sides have tended to admit moisture, sand, and salt air into these pipes. Severe internal corrosion has been found on some towers with such members. Inspection by tapping or scraping the undersides of the members and by the use of ultrasonic devices has been attempted, with limited results. Inspectors should be alert to the possibility of this kind of hidden damage, and the Tall Tower Coordination Center should be notified whenever a serious problem is suspected.
8. Latent Defects. Latent defects in structural materials such as forging bursts can usually be detected only by special testing, most of which requires removal of the particular tower component for field or laboratory analysis. Microscopic structural defects can develop into serious problems or even tower failure without the benefit of any prior visual indication of abnormality. Whenever there is reason to suspect the structural capacity of a particular tower component, full advantage should be taken of any maintenance project which would permit the removal and examination of the suspected part. It may be advantageous to permanently replace the part so that it can be subjected to a laboratory examination.
9. Analysis and Evaluation of Defects. Whenever a defect on the tower is found, an overall evaluation of the tower should be conducted. As an example, one or more tower diagonals may be found to be bowed. Since diagonals are usually tension members, the bowing may indicate that unacceptable compressive forces are acting on the diagonal and that the cause of the condition lies elsewhere. (See Ch. 5 ►C.5.a(3)) As another example, tower misalignment may be caused by several conditions such as settlement of the base pier, movement of the guy anchors, stretching of the guy cables, loose bolts, broken insulators, slippage of guy hardware, or damaged tower structural members. Thus all detected abnormalities must be analyzed together to determine the actual causes, in order to ensure that proper corrective measures are taken.

D. Common Abnormalities. The most common conditions with which the inspection process is concerned are tower misalignment, wear, deformation, corrosion, improper guy tensions, and damaged structural members.

1. Tower Misalignment. Guyed towers are designed to deflect when subject to wind and ice loading conditions, and some degree of misalignment can occur under normal service conditions. See Figure 3-1. This subject is discussed in Chapter 8.
2. Wear and Deformation. Some degree of mechanical wear of structural elements such as guys, fittings, shear pins, turnbuckles, thimbles, etc. can be expected under normal service conditions. This subject is discussed in Chapters 5 and 6.
3. Corrosion. Since most Coast Guard towers are located in marine environments, corrosion in the form of highly localized corrosion cells will be most evident. Corrosion of anchor steel in direct contact with the soil will vary over a wide range depending on the corrosivity of the soil. The destruction by corrosion takes many forms depending on the nature of the metal or alloy and the presence of water, oxygen, and ions in the environment. In combination with these essentials are the influences of numerous variables such as temperature, stresses, area effects, and stray electrical currents. In most cases visual inspection before cleaning of the corroded components will provide valuable information leading to the solution of a corrosion problem. Chapter 5 and 7 discuss this problem further. The following references provide extensive information on treatment of corrosion and its prevention as it relates to towers:

Annex J of Structural Standards for Steel Antenna Towers and Antenna Supporting Structures, TIA/EIA-222-F, Electronic Industries Association, Washington, D.C.

<http://www.corrosionsource.com> Corrosion Source Portal

"Understanding and Preventing Guyed Tower Failure Due to Anchor Shaft Corrosion", Craig M. Snyder, Sioux Falls Tower Specialists Inc. published in 1994 Broadcast Engineering Conference Proceedings, available at http://www.anchorguard.com/reference_understand.cfm.

- a. Atmospheric Corrosion is primarily due to the effects of moisture and oxygen, accentuated by contaminants such as sulfur compounds and salt. In a marine environment, sea salt particles are carried by the wind and settle onto exposed surfaces. The presence of moisture (rain, dew, condensation, or high humidity) on contaminated surfaces triggers the corrosive effects. In the absence of moisture, most contaminants would have little or no corrosive effect. The shape of structural elements has an important bearing on the life of metals exposed to the atmosphere. Joints, pockets, cavities, crevices under bolt heads, and other areas where good drainage is not provided can be expected to develop intense localized corrosion. Salt contamination decreases rapidly with distance from a saltwater body, and is greatly affected by wind currents. Corrosion on the windward side of tower elements can be expected to be more

intense because of the erosion of the paint and galvanizing caused by the wind-driven rain, salt and dust.

- b. Galvanic Corrosion. The use of tower parts made of dissimilar metals coupled together leads to the formation of galvanic cells and results in corrosion at the point of contact. A galvanic cell consists of two dissimilar metals in contact and a common electrolyte. A galvanic couple is created where a portion of a piece of metal is encased in concrete, such as tower anchor arms. Bare steel is anodic to concrete-covered steel, and localized corrosion of the bare portion can often result. The arrangement of several metals according to their relative potentials in a given environment has been termed the galvanic series. The series shown in Table 3-1 has been developed for a marine environment. When any two metals in this list are coupled in the presence of an electrolyte the one with the lower number will corrode. Also, the further apart the metals are in the list the greater will be the corrosion rate.

Table 3-1 Galvanic Series

#1	Zinc	#6	Lead
#2	Aluminum	#7	Tin
#3	Steel	#8	Copper
#4	Iron	#9	Stainless Steel (passive)
#5	Stainless Steel (active)		

Galvanic corrosion has beneficial applications, such as the anodic protection of steel by coating it with zinc (galvanizing) or aluminum. Where dissimilar metal contact cannot be avoided, it is good practice to select materials as close as possible in the galvanic series, to insulate dissimilar metals, and to prevent moisture from reaching the contact area through the use of impervious coatings.

- c. Soil Corrosion. Soil is considered to be a good, but variable, electrolyte and any metal in direct contact with soil is considered to have a high potential for corrosion. The degree of corrosion is influenced by the properties of the soil. This type of corrosion can be expected on all portions of anchor arms which are exposed directly to corrosive soils. Generally, poor aeration and high acidity, electrical conductivity, salt, and moisture, and sulfur content are characteristics of corrosive soils. The zinc coating on anchor steel will protect the base metal as long as a sufficient amount of the coating remains. When the zinc coating is inadequate, corrosion of the base metal will be accelerated. Protection of anchor steel in contact with the soil should be considered. (i.e. Concrete or NO-OXIDE grease can be used.)
- d. Stray Current Corrosion occurs on sub surface metals. It differs from all other forms of corrosion in that the electrical current that causes the corrosion process has a source external to the affected metal structure. This type of corrosion is generally associated with direct current, which may be caused by generating equipment, battery chargers, DC components from electronic equipment, and lightning. The corrosion process results when

current from these external sources flows on a metal, leaves the metal, and enters the surrounding electrolyte. When stray currents reach high amperages, metal removal can be extremely rapid. It is important that guy anchors are grounded to help avoid stray currents from entering the steel in the anchor.

- e. Stress Corrosion Cracking is the development and propagation of cracks in metals and alloys caused by the combined effects of corrosion and static tensile stresses. The stress may be residual, as from cold working or forming, or may result from external loading. Neither the tensile stress nor the corrosion acting alone will cause the cracking; both are necessary to produce a stress-corrosion crack. Failure in this case is a spontaneous brittle fracture of an otherwise ductile metal, sometimes at stress levels considerably below the yield strength of the material. Chloride ions are an almost universal accelerator of stress corrosion in the atmosphere, affecting stainless steels, aluminum, and magnesium alloys, but not affecting most nickel-based alloys.
 - f. Corrosion Fatigue is a special case of stress corrosion. It is defined as the reduction of fatigue resistance due to the presence of a corrosive medium. Corrosion produces pits, notches, or other starting points on the metal surface for the concentration of stress and the initiation of fatigue cracks. Under continuous cyclic stresses, these pits increase in sharpness and depth, and become the origin of microscopic cracks that propagate until one of the cracks progresses across the entire section, causing failure. Localized corrosion at cracks and pits in protective coatings such as zinc, or on structural steel elements on the tower and guys, can be much more harmful from the standpoint of the potential loss of the fatigue strength of the member.
4. Breakage and Damage. Cracked, broken, bent, or otherwise damaged structural components can occur from a variety of causes, such as premature failures and foreign object damage. Most of these conditions can be readily observed through a careful and thorough visual inspection. Cracks propagating as a result of fatigue can only be detected by non-destructive methods such as magnetic particle (Magnafluxing), dye penetrant, ultrasonic, etc. Weld and bolt connections are primary areas where visually detectable cracks or breaks can be expected to occur. Broken or frayed guy strands will more likely occur at the connection points of the end fittings or mechanical clamps (see Figure 4-2). Cracks and breaks can also be expected where there is an abrupt change in cross-section of a part.



Figure 4-2 Broken strands on TLE.

5. Failures in a 625-ft or 700-ft. Loran-C Tower Radial Guy. Several radial guy failures have occurred on 625-ft Loran-C towers. Most failures are attributed to the hidden corrosion of the steel core of ACSR cable. The following steps should be followed should such a failure occur:
 - a. Failure in the grounded portion of the guy. Retension using any suitable material as a temporary guy or as a splice near the broken section. Attempt to achieve the original breakup insulator pattern.
 - b. Failure in the TLE or at the lower, strain-insulator end of the TLE. Lash the broken TLE to the tower and slacken the opposing radial guy to a tension of a few hundred pounds. When lashing, use nonconductive line to minimize arcing and wear. Before lashing, bond the TLE to the tower in accordance with Evolution #5 of Appendix E, or de-energize the tower. If repairs cannot be effected soon, the opposing TLE should also be lashed to the tower and the grounded portion of the guy disconnected.
 - c. Failure at tower end of TLE. Slacken the opposing radial to bring the tower alignment to within 6 inches of plumb at the top. If necessary, increase the tension in the two radial guys adjacent to the failed guy to a maximum of 150% of the specified initial tension. If a new Big-Grip location is necessary, install a new grip rather than repositioning the existing grip. As an alternative to these tension adjustments, the opposite TLE may be lashed to the tower as described in paragraph b above.
- E. Replacement of Structural Members. The decision to replace a major structural component in lieu of repair is most difficult. Such decisions should be made only after a thorough engineering evaluation of the condition has been made and less expensive and less hazardous corrective

measures such as shoring or reinforcement have been fully explored. Considerations when replacing tower members are:

1. A temporary member **should always** be installed before removal of the permanent member.
2. Since most temporary members will be installed eccentrically, allow for the abnormal stresses due to the eccentricity.
3. The temporary member must be designed to clear all obstructions, and to permit removal of the permanent member.
4. The temporary member should be adjustable in length when installed, to allow for removal of the shear load from the permanent bolts.
5. Permanent bolts should also be renewed.
6. If at all possible, bracing should be designed to permit installation of the replacement member prior to removal of the old member.
7. An important element which should always be considered in reaching the proper decision is the built-in safety factor of the particular structural component. The residual strength of the component will not only affect the decision, but in most cases will also determine the urgency involved. Field or laboratory testing is recommended whenever the structural integrity of the tower or its components is uncertain. The following is an example of a testing program which has provided a better understanding of tower conditions, has avoided unnecessary maintenance, and has postponed off-air time: Several fiberglass Insulator pairs on a 625-ft. tower were severely twisted. Following some corrective action (see Ch. 6 ► J.2.a(5)), a few insulators were removed for testing. The rods proved to be as strong as originally specified, and the decision was made to keep the existing previously-twisted rods in service.

CHAPTER 5. TOWER STRUCTURE

- A. General. A wide variety of structural materials are used in the fabrication of Coast Guard towers. Whenever possible, tower purchase specifications are developed around those materials which provide the highest degree of maintainability consistent with structural requirements and economical costs. This Chapter is devoted to structural components of the tower that are not associated with the guys or guy anchors. Such components include vertical, horizontal, and diagonal members, fasteners, foundations, and base insulators. It outlines their most important characteristics and inspection and maintenance requirements. Steel antenna towers and other supporting structures should be analyzed when changes occur to the existing design or operational loading conditions. This is required when any additional antenna or appurtenance is contemplated which was not accounted for in the original design. Additions of any antennas or appurtenances, beyond those contemplated in the original tower design, must be evaluated by a structural engineer. Specifically, requests from other government agencies and commercial companies to place communications equipment on CG property must comply with the application criteria as outlined by MLC. This chapter will also provide instruction on the procedure for determining tower leg and face designations.
- B. Standard Tower Leg and Face Designations. The following conventions shall be used to designate tower legs and faces. The use of these conventions is very important to avoid confusion in inspection reports and correspondence. This section provides information on the designation of tower legs and faces only. Conventions for the designations of guy lanes and guy levels are provided in Chapter 6 of this manual.
1. Tower Legs. When a ladder is mounted on or inside a tower leg, that leg is leg "A". When a ladder is mounted on or integral with a tower face, the leg which is at the right hand of a climber on the outside of the tower looking in through the tower framework is leg "A". Viewing the tower from above, the remaining legs are designated "B" and "C" in a clockwise order (Figure 5-1).
 2. Tower Faces. A tower face is designated "A", "B" or "C" according to the designation of the leg which precedes it in a clockwise order when the tower is viewed from above (Figure 5-1).
 3. Tower Sections. The leg joints/flanges define the beginning and end of each "section". Sections are designated by numbers "1", "2", etc., beginning at the base of the tower (Figure 5-1).
 4. Tower Panels. The portions of the tower between horizontal members are called "panels". They are numbered from the bottom upward in each section. For example, panel 2-3 is the third panel upward from the bottom of section 2 (Figure 5-1).
- C. Structural Members. Structural grade galvanized steels and aluminum alloys are used for tower structural members. These materials are used in a variety of shapes and sizes and they are selected for their strength, weldability, galvanizing qualities, resistance to corrosion, general workability, and economy.

Structural aluminum alloys in various shapes (usually extrusions) are used for the smaller towers, generally up to 130 feet in height. Structural steels are utilized for the taller towers. Stainless steels are used for special purposes such as where greater corrosion-resistance is required. For all applications, structures are designed with a safety factor or allowable stress which allows for variances in the materials, workmanship, handling, the uncertainties of the ultimate loading forces, etc.

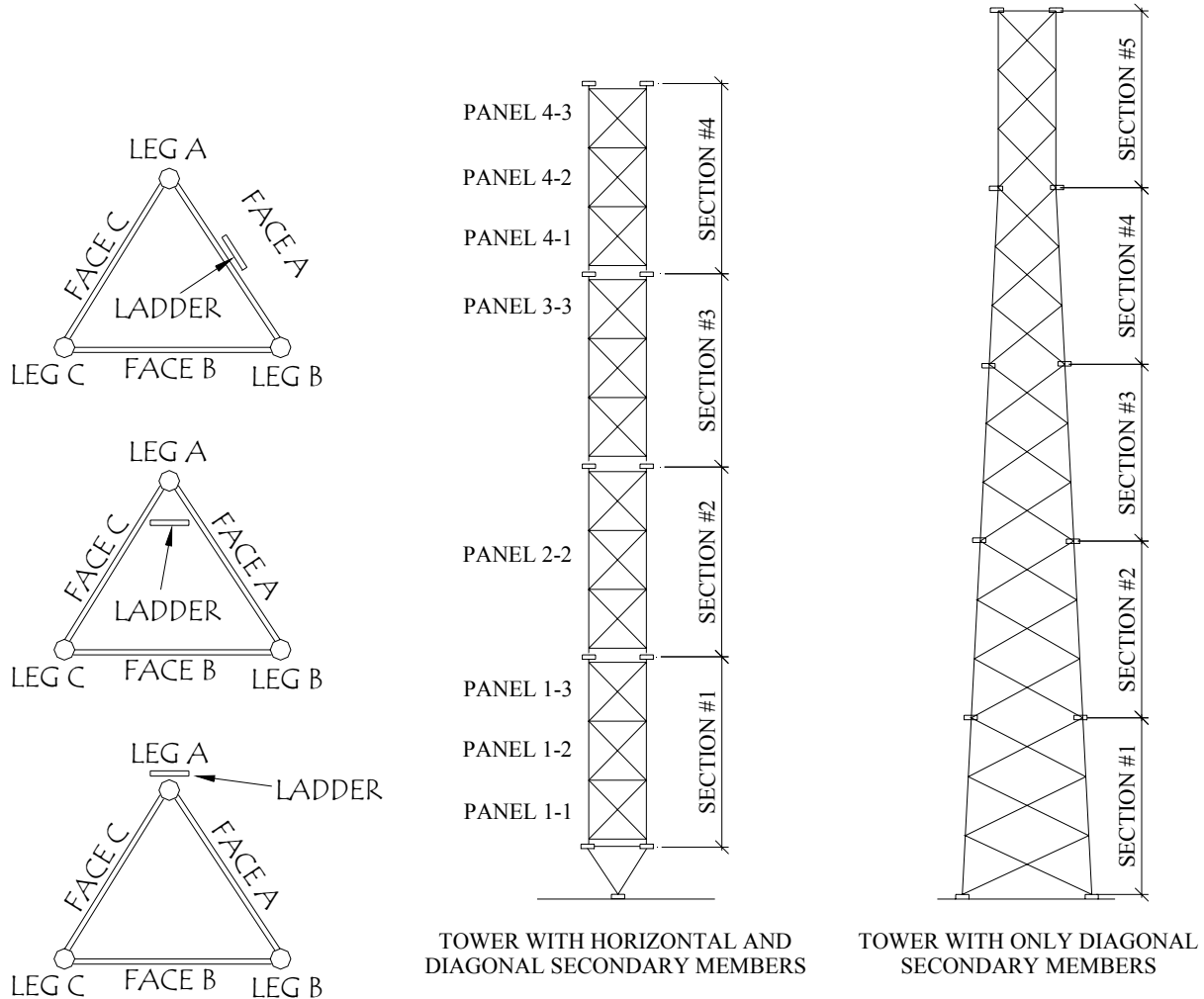

Figure 5-1

1. Galvanized Steels. Structural grade steels of solid shapes are generally furnished to the American Society for Testing Materials Specifications ASTM A36, a mild steel with good weldability. ASTM A7 steel has been used to some extent, but its specification has been discontinued in favor of A36 steel. In addition many steel towers are increasingly using 50ksi and other high-strength low alloy steels including A572 Grade 50, A242, A588. Welded and seamless pipe is generally furnished to ASTM A53 or A501 and for high strength A618, or to American Iron and Steel Institute (AISI) standard carbon steel compositions, C1010, C1020, C1025, C1045, C1055. The properties of most steels furnished under these and other generally accepted

standards can be changed radically by subjecting the steel to various heat treatment processes and manufacturing procedures. Considering the wide variety of structural steels, it is of utmost importance to know exactly what type of material is involved before reworking (welding, heating, straightening, etc.) or replacing any structural component.

2. Protective Zinc Coating. All tower structural steel members are galvanized to ASTM A123 that specifies a hot-dip process. The zinc coating is applied by immersing a completely fabricated structural member in a bath of molten zinc for a controlled period of time and at a temperature between 830 and 860°F. This process develops a layer of iron-zinc alloy next to the steel and an outer layer of relatively pure zinc. The galvanizing layer on steel can last from 10 to 40 years depending on the severity of the environment and the quality of the original construction. With few exceptions, galvanized surfaces have a common method of failure that is usually characterized by color and general appearance. When malleable iron or low carbon-steel galvanized structures are new, the galvanizing is a light, bright metallic color, sometimes with the characteristic spangled effect readily apparent. After about a year or more of normal weathering, this brightness usually disappears and the steel takes on a more uniform, dull grayish appearance which it maintains for many years. Just prior to failure, a severe darkening of color may be noted. This will probably first be observed on the sharp edges where the zinc film is the thinnest, on the upper portion of horizontal members, and on the windward face of those towers subjected to a prevailing wind. If this blackening change is noted on the structure in general, it is a good indication that the useful life of the galvanizing has been expended. This condition is the forerunner to active rusting. If painting is accomplished at this stage, very little surface preparation will be required and the galvanizing layer will function as an integral part of the maintenance paint system. Corrosion of the base metal is readily identified by rusting. Another type of common galvanizing failure is attributed primarily to the sandblast effect (erosion) of wind driven particles such as sand and water. Where steel is exposed to strong winds, the abrasive actions of these particles eat away at the softer zinc metal and do not allow time for the customary darkening action and more graceful type of failure. Under these exposures, the steel surfaces take on a reddish stained appearance indicative of minute pinhole damages, where corrosion may already be started to a very light degree. When this type of failure occurs, it is important to get a coat of paint on the tower as soon as possible to prevent the spread of such corrosion and the accelerated breakdown of the galvanized coating.
3. Structural Aluminum Alloys. A wide variety of aluminum alloys are available. Their strength, resistance to corrosion, weldability, and formability are developed by varying the chemical compositions and tempering processes. Structural aluminum alloys currently in use are ANSI Alloy designations 6061-T6 or 6063-T6. These types of aluminum alloys are heat treated, artificially aged, and have the desirable characteristics of light weight as well as high corrosion-resistance, weldability, and strength. Type 2024 Aluminum has been used in the past with very poor results and should not be used. As in the case of structural steels, it is of the utmost importance to know the

exact type of aluminum alloy involved before any reworking or replacement is accomplished.

- a. Self-Protection. The exposure of aluminum alloys to the atmosphere causes an almost immediate formation of a thin invisible oxide film. This film tends to protect the metal from further oxidation by preventing corrosion from penetrating deeper into the metal itself. Where corrosion occurs, it is usually in the form of localized pitting and the rate of corrosion generally falls off with an increase in exposure time. Despite the high degree of corrosion resistance, aluminum alloys are considered one of the most active of the structural metals used for tower construction and they can decompose rapidly when in contact with other metals due to galvanic action. (Figure 5-2 is a good example of this kind of problem, where galvanized steel guy pull-off plates were fastened directly to the 6063-T6 aluminum leg of a 129 foot Loran-A tower.) Some aluminum alloys can be anodized at the factory to improve the surface resistance to corrosion. Other protective coatings such as paint are not normally applied to aluminum structures unless the structure is installed in a highly corrosive environment (see Chapter 7).
4. Stainless Steels. Corrosion-resisting (stainless) steels are alloys with varying compositions of chromium, nickel and copper. These steels are available in a wide range of physical characteristics and are furnished to AISI composition ratio designations. The two important characteristics which differentiate stainless steels from ordinary carbon steels are coefficient of thermal expansion and resistance to corrosion. Generally, the expansion and contraction of structural stainless steels is 35 to 60 percent greater than carbon steels. Despite the high degree of general corrosion-resistance, stainless steels are subject to corrosion from galvanic action. However, the damage from such action is only about one-third that of ordinary steel subjected to the same conditions. As in the case of aluminum alloys, stainless steels obtain their corrosion-resistance properties by the formation of a very thin transparent surface film that develops naturally when the steel is exposed to the atmosphere. When corrosion occurs, it can be expected to be in the form of localized pitting similar to that which is characteristic of aluminum alloys. It is again emphasized that the exact type of stainless steel must be known before reworking or replacing a structural component. The benefits of the corrosion-resistance properties of stainless steels must be weighted against the relatively high cost of such material compared to other metals. Even where the combined factors of corrosion resistance, strength, and low maintenance makes the use of stainless steel a sound investment, the higher cost is normally justified only for cotter pins, safety rails, gradient rings, and, in some cases, bolts and nuts. Type 304 stainless steel is commonly specified. Type 316 offers higher resistance to marine atmospheric corrosion, but its greater cost is not normally justified. Special high tensile strength stainless steels are used for the rocker assemblies in the large compression cone insulators on the 1350-foot towers (see Ch. 6 ► J.1.b(1)).

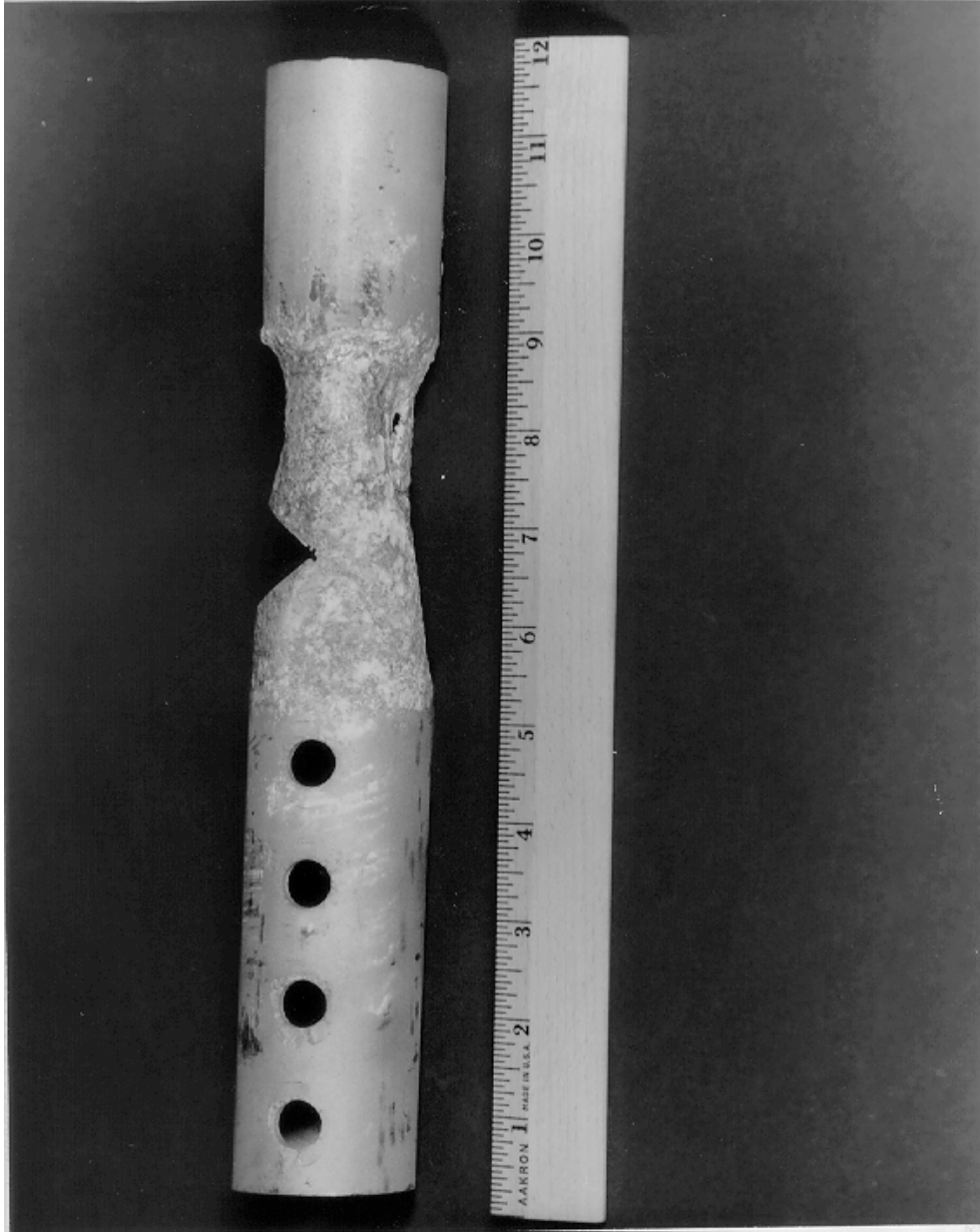

Figure 5-2 Galvanic corrosion on aluminum leg of 129ft tower.

5. Structural Applications. Generally, all structural components on taller towers are made of galvanized steel. They include leg members, diagonals, girts, gusset plates, etc. in various shapes such as solid rounds, pipe, angles, channels, and plates. Galvanized high strength steel bolts and nuts are used for connecting the assemblies of prefabricated welded parts. The structural components on the smaller towers are generally made of aluminum alloys. The structural members of these smaller towers are generally made of extruded angle shapes and tubing.
6. Inspection and Maintenance. Inspection and maintenance of structural metals will be concerned with corrosion, wear, deformation, and

premature failures. Corrosion control normally requires the most attention.

- a. Galvanized Steels. Protection of the galvanizing by maintaining the protective coating system over the galvanizing should be the thrust of the corrosion control effort for galvanized steels. In cold marine environments, corrosion of galvanized steels is a slow process and very little, if any, effort is required to protect the zinc. However, in tropical marine environments with prevailing winds, protection of the zinc requires a considerable effort. Experience has shown that once corrosion of the steel has begun in such a severe environment, it cannot be stopped without a surface preparation that removes the rust completely. This requires intensive grinding (which is discouraged) or abrasive blasting. Efforts to slow the corrosion process by accepting a surface preparation method which removes only the worst rust are very costly over time and the success of these efforts is questionable at best. Failure of the protective coating over the galvanizing is discussed in Chapter 7. The galvanized surface will first show signs of corrosion by the formation of a bulky white substance. The next stage will be the formation of a bright yellow product resulting from corrosion of the zinc-iron alloy layer formed on the surface of the base metal. Since most galvanized surfaces are painted, the loss of the galvanized coating and the occurrence of rust because of an improperly maintained protective coating system over the galvanizing may not be apparent. If there is a fracture of sufficient size in the paint coating, the rust will appear at the surface. Where the paint film appears to be intact, but is minutely cracked, rusting can occur beneath the paint film. This condition can be detected by the appearance of blistering or buckling of the paint surface. Since this condition can also be caused by the loss of adhesion of the paint film, the coating should be scraped off to the extent necessary to determine if rusting is taking place. Dissimilar metal contact points should always be closely examined. On some 625-foot towers and many small towers, leg members are made of pipe that is galvanized inside and outside. The accumulation of dirt and other foreign matter inside hollow members is a good breeding ground for corrosion. In some cases, open-end members have been sealed after tower erection. Depending on the quality of the seal, this effort may eliminate the cause of internal corrosion. As a means of determining if there is a reduction in wall thickness due to internal corrosion, leg member inspections should call for random sounding, particularly in the vicinity of the flanges, by means of a hammer or wrench. Admittedly, tapping with a hammer or wrench is not a very reliable method of determining wall thickness. However, the proven method of sample replacement of suspect members for internal inspection is not practical for structural members other than diagonals and horizontals. Ultrasonic testing has proven to be just as unreliable as member tapping for the small-diameter 625 foot tower members, and is much more expensive to perform. Corrective treatment for exposed surface areas should be accomplished as described in Chapter 7. When internal corrosion is detected in horizontal or diagonal members, full-scale member replacement is recommended. If

internal corrosion is detected in tower legs, notify the servicing CEU.

- b. Aluminum and Stainless Steels. Corrosion of aluminum alloys and stainless steels can initially be identified by pitting of the metal surfaces. Severe corrosion of aluminum alloys can be exhibited by pronounced exfoliation of the material in which the corrosion product expands, causing a laminated and flaked surface. With proper controls, this degree of corrosion will not occur. As in the case of galvanized pipe sections, inspection should require random sounding, or where practical, random replacement and sampling of aluminum tubing structural members in an effort to detect internal corrosion. When pitting of aluminum metals becomes severe, corrective treatment should be accomplished as described in Chapter 7. Stainless steels should not require a great deal of maintenance, but they should nevertheless receive periodic inspection. A build-up of dirt and other contaminants can cause corrosion in the form of pits or staining. Cleaning such surfaces should be all the maintenance that stainless steels will require. However, if severe forms of corrosion are found, a coating of paint as described in Chapter 6 for aluminum surfaces should be applied, except that working and bearing surfaces should remain uncoated. Since both aluminum and stainless steels are subject to galvanic corrosion, contact points with dissimilar metals should always receive special attention.
- c. Wear, Deformation, and Failures. Most forms of wear, deformation, and failures of parts and welds can usually be detected through close examination during periodic tower inspections.
- (1) Wear. Wear or abrasion on major tower structural members will rarely be a problem. This condition can occur at bolted connections where the bolts are not properly tightened and at the guy connection points. Where this condition is found at bolted connections, the bolts should be renewed. Minor wearing at guy shackle connections can be expected due to movement of the guys and should not require action unless the condition becomes progressively worse (see Ch. 6 ► I.3).
 - (2) Deformation. Permanent deformation of a structural member indicates that it has been stressed beyond the elastic limit; if this deformation is significant, the tower may be in jeopardy. Deformations of this kind may or may not be detectable through an instrument check or binocular inspection. When bends are observed, a straightedge should be placed parallel to the affected member and the amount of deflection measured as accurately as possible. Subsequent straightedge checks should then be periodically performed in order to determine the degree of any further deflection. If the deflection is found to be progressive, immediate corrective action must be taken.
 - (3) Bowed Diagonals. In tall towers with tension-only diagonals, bowing of these diagonals is fairly common and is not normally a cause for concern. Bowed diagonals are usually a result of

built-in dimension tolerances of fractions of an inch which are sufficient to cause a bow off-set of an inch or more. Some diagonals slip in their bolt holes while under a tensile load and then cannot return to their original position because of their high slenderness ratio. If bowing of diagonals in a particular tower is widespread, or if serious defects or overloading is suspected, the situation should be reported to the servicing CEU and to the Tall Tower Coordination Center.

(4) Deformation in Plates. Deformed plates are often the result of fabrication errors or damage during erection. Replacement of plates is usually impractical because most plates are welded to larger structural members on the tower. Attempts to straighten bent plates by hammering or other means should not be made. Deformation may also occur in pinned or bolted areas of plates if the yield strength is exceeded. This can be noted only by a very thorough inspection. If deformation induced by service loads is suspected, the situation should be reported to the servicing CEU and to the Tall Tower Coordination Center.

(5) Cracks. Cracks, unless microscopic, can be detected by close examination. With the exception of aluminum towers, structural components are usually prefabricated by welding. Fillet welds are the most common in tower fabrication. Cracks can occur in any portion of a weld, but are most likely along the line of contact with the joined members. Cracks in pinned and bolted plates can occur if the stresses at a hole exceed the ultimate strength of the plate material. Immediate corrective action must be taken when cracks are found, and proper and safe repair techniques must be applied.

7. Structural Steel Bolts and Nuts. High strength steel bolts and nuts conforming to ASTM A325 are generally used for the final assembly of steel and aluminum tower components. These fasteners are made of medium carbon steel and are galvanized to ASTM Standard A153. Under certain conditions, hardened washers are also used. Interference-body interrupted-rib bolts, which must be hammer-driven to achieve proper positioning, have been used on several of the taller towers. Special conditions may exist which justify installation of these bolts (see ►C.5.c(3) above). Jam nuts are thin nuts that are used under full sized nuts to develop the locking action through deformation of the jam nut. They are frequently applied to the wrong side of the main nut, where their usefulness as a locknut is decreased. PAL nuts are a common type of self-locking nut that are frequently used on Coast Guard towers manufactured by *ROHN Industries*. Unlike jam nuts, PAL nuts and other self-locking nuts are installed on top of the full sized nut. The most common type of self-locking nut is the ANCO locknut, which achieves its locking characteristic by an integral steel locking pin. The pin engages the bolt thread as the nut is tightened and acts to hold the nut in its final tightened position. Self-locking nuts are reusable, and should be installed in lieu of jam nuts on new structures or when replacement is required.

a. Bolt Tensioning Methods. All bolted structural connections on a tower are subjected to dynamic forces that may cause the

fasteners to loosen. Where the main nut is in contact with the structural surface, proper tensioning of the bolt helps prevent loosening. Tensioning of high strength bolts is accomplished by two methods accepted by the American Institute of Steel Construction (AISC): the calibrated wrench method and the turn-of-the-nut method. Unfortunately, there is no correlation between these methods. A discussion of the differences between, and the philosophies behind these three methods is beyond the scope of this Manual: AISC specifications and commentaries should be consulted for a greater detailed discussion. General Coast Guard policy in the past has required turn-of-the-nut method. New bolts installed in existing towers shall use the turn-of-the-nut method. Construction of new towers may use either the turn-of-the-nut method or calibrated torque wrench method as approved by AISC.

- b. Inspection and Maintenance. Bolt tension checks have little apparent value. On painted towers, cracking or peeling of the paint will tend to indicate movement or loosening of the bolt, and tapping the bolt with a small hammer or wrench is a very good indicator of looseness. The bolted joints in nearly all towers are bearing-type connections. While the performance of bolts in bearing is not dependent upon high tension, loose bolts are clearly not desirable. Overall, visual and tapping inspections are adequate for checking bolts. The following is the current policy for inspection and maintenance of high strength bolts:

- (1) Periodically check tower bolts visually and manually, but not by torquing.
- (2) If a bolt is loose, replace it in kind. Use an ANCO self-locking nut. The threads should be on the outer face of the tower structure or on the upper face of leg flanges.
- (3) If it is desirable to inspect a bolt or connection by loosening the nut or removing it, do not reuse the bolt. Do not remove more than one bolt from a connection at any one time. The bolts in a single-bolt connection shall not be removed except as described in Chapter 4 ► E.

8. Aluminum Bolts and Nuts. Aluminum bolts and nuts provide optimum material compatibility with aluminum structures, and may be used for aluminum towers. Bolts are usually made of 2024-T4 alloy. However, the low corrosion resistance property of 2024 aluminum in marine environments justifies the slight additional expense of using 6061-T6 or the stronger 7075-T73 alloy fasteners. The clamping load developed in an aluminum bolt at a given torque value or at a given rotation of the bolt head or nut can vary widely depending on bolt and nut materials, thread fit, condition of the bearing surface under the part being turned, the grip and makeup of the joint, and lubrication. Over-torqued aluminum fasteners are highly susceptible to stress corrosion, especially if the fastener has been loosened and retightened. It is therefore very important that aluminum fasteners be properly torqued during erection, and controls established to avoid over-tightening during tower maintenance or inspections. Experience has shown that torque or rotating values for a particular application are best established through trial on the job site or by

means of pilot models. One method often implemented is to tighten several bolts to the breaking point, under the same conditions as will be encountered on the job, and then use 70 to 80 percent of the lowest torque obtained for tightening all bolts. Lubricating the aluminum fastener will enable clamping loads within 5 to 10 percent of the tensile strength of the bolt. A good petroleum based lubricant will also ensure consistent results, regardless of the tightening method used. In a bolt and nut combination where the nut is to be turned, a thorough lubrication of all the surfaces of the nut is usually all that is necessary to attain the advantage offered by the lubricant.

9. U-Bolts. U-Bolts are typically installed on tower ladders and at diagonal crossing points. When galvanized, they are usually very quick to corrode. Stainless steel U-Bolts should always be used as replacements.

D. Base Insulators. Loran and other towers that are radiating antennae are insulated from the supporting base pier by a base insulator. The types of base insulators in use on Coast Guard towers employ a hollow porcelain dielectric in various forms. These insulating elements are supported by attached steel caps and plates that distribute the compressive loads to the ceramic. A safety factor of 3 is used as a basis for selecting the size of these base insulators.

1. Compression Cone Type. Single cone-shaped base insulators are generally used for the smaller guyed towers. See Figure 5-3. Double inverted cone insulators that provide higher electrical characteristics are used to support some 625-foot towers. See Figure 5-4. The porcelain elements are smooth surfaced and either straight or curve sided for these applications. They provide the high compressive strength necessary for tower support (the curve side being the stronger) as well as the required electrical characteristics. These types of insulators are long lead-time delivery items.



Figure 5-3 Cone shaped base insulator.



Figure 5-4 Double cone base insulator.

2. Single and Multiple Cylinder Types. Single cylinder insulators are used for support of some 625 and 700 foot towers. See Figure 5-5. They are filled with oil, and some of them contain isolation transformers for tower obstruction lighting. The porcelain element surfaces are smooth and the ends are cemented to steel end plates. Multiple cylinder base insulators are used for 625 and 1350 foot towers. The number of cylinders in this type of insulator varies from 5 for 625 foot towers to 21 for the 1350 foot Loran-C towers. See Figure 5-6. The construction of these insulators is unusual in that the hollow cylinders are set in gasket seals and are held in position between a top and bottom steel bearing plate by compression alone. Prior to placement in service, load is applied and held by tension rods connected between the two bearing plates. After tower erection, the tie rods are removed and the tower provides the compressive load that keeps the cylinders in their proper position. The cylinders are normally oil-filled with Volt-Esso #35 or any good transformer oil, and air vents and drains are provided in each cylinder through nipples screwed into the sides of the bearing plates. They are made to special order and are long lead-time delivery items.
3. Inspection and Maintenance. Insulators require periodic inspection for cracks, broken elements, corrosion of their metal parts, and contamination of the glazed surfaces of the porcelain elements. Generally, corrosion and contamination control will require the most inspection and maintenance attention.
 - a. Inspection. The porcelain insulator elements in current use have provided reliable structural service even after they have developed cracks or become chipped. Such condition may, however, reduce the dielectric strength of the insulator. Therefore, cracks or other structural damage to the porcelain elements should always be considered serious and inspection should strive for their early detection. Statifluxing the surface of base insulators will highlight hairline cracks that may not otherwise

be visible. See Figure 5-7. Statifluxing is more fully described in Appendix E. The truncated porcelain cones of base insulators should be checked for signs of fracturing and spalling, particularly around the joint with the metal cap on the small end. Similar failures in cylindrical porcelain elements will generally occur as longitudinal fractures. Spalling may also occur where their ends contact the supporting bearing plates. Evidence of arc-over can be an indication of cracks in the porcelain elements. In oil-filled insulators, oil leaks can also be indicative of cracks in the elements.



Figure 5-5 Oil filled cylindrical base insulator.



Figure 5-6 Oil-filled multiple cylinder base insulator.

- b. Maintenance. Porcelain insulator elements will require little, if any, structural maintenance. Cracked or otherwise seriously damaged single element base insulators must be replaced as soon as possible after detection. A similar condition in an element of a multiple element base insulator may not require replacement of the insulator depending on the location and severity of the damage. Any such damage to base insulators should be immediately reported to the servicing CEU for determination of corrective action. The elements of this type of insulator cannot be replaced in the field since the ends of the porcelain cylinders must be ground to close tolerances to provide necessary support in combination with the other elements. Metal parts of insulators should be maintained as indicated under paragraph ►C.5.a above. Contamination on insulator porcelains should be washed or wiped whenever arcing across the insulators becomes objectionable. Buffing the porcelain surfaces after an application of a very thin coat of silicone grease has been found to be effective in preventing contamination flashovers in some areas.



Figure 5-7 Statifluxing an oil-filled base insulator.

- c. Base Insulator Replacement. Most insulated guyed towers between 280 and 1350 feet in height have been designed with jacking plates under the tower legs for the purpose of base insulator replacement. Base pier jacking plates and jacking legs have been furnished with some towers. In most cases, jacking procedures of these towers are contained in the manuals provided by the tower designers. Base insulator replacement is discussed in detail in Appendix D.
- E. Tower Base. The tower base foundations are normally constructed of reinforced 3,000psi concrete and are designed to support the vertical and horizontal (if self supporting tower) forces imposed by the tower. The two major elements of tower base foundations and guy anchors are

discussed below. Concrete is considered to be a permanent structural material and when properly designed, mixed, and placed, should last indefinitely. To fully serve its purpose in foundations and encasements, concrete must be of high quality and of sufficient cover over the embedded anchor bolts and reinforcing steel to protect them from corrosion. Only high quality concrete can withstand continued exposure to water, freezing and thawing, and other adverse conditions. Considering the locations of various towers and the conditions under which they were erected, it should not be taken for granted that all foundation and encasement concrete is high quality and fulfilling its intended purposes.

1. Inspection of Components. Inspection of the tower base foundation presents a difficult problem in that the major elements of these structures are concealed. The means for accomplishing subsurface inspections are discussed under Ch. 4 ►C.6. Inspections of exposed and exposable galvanized steel should be guided by the discussion in ►C.5.a above. The timing or frequency of inspections should be determined by the major field commander based on the soil conditions, corrosive environment and history involved. The inspection should note and record the surface condition of anchor bolts and exposed steel. In the event a substantial loss of cross-section or other structural deficiency, the servicing CEU should be consulted as to proper corrective action before proceeding further. Structural and encasement concrete should be checked for cracks and spalls, mechanical damage, and erosion. When subsurface concrete is exposed, the surfaces should be tapped and probed with a chisel or screwdriver to check for soundness and integrity of the concrete. Cracking and spalling, with or without surface indications of rust, can be caused by mechanical damage, expansion pressure resulting from rusting of embedded steel, or expansion of salt and ice crystals in the pores of low quality porous concrete. Erosion of concrete can be caused by surface or subsurface water action.
2. General Above-Ground Inspections. The tower base foundation piers should be checked periodically for settlement or lateral movement. Slight vertical and horizontal movements cannot be detected with the unaided eye, but movements of serious proportions can be visually detected. Such inspections should look for evidence of mounding or folding of the soil at the sides of the foundation with an accompanying crevice on the other side. Such a condition would be indicative of differential settlement of the tower base pier. Where there is reason to suspect pier movement, periodic instrument checks should be conducted.
3. Maintenance. Whenever normally hidden foundation elements are exposed for inspection, preparations should be made to accomplish anticipated maintenance at the same time. The most common form of maintenance will consist of patching cracks and spalled areas in the surface and subsurface concrete elements.
4. Drainage and Landscaping. In order to preserve the original design conditions, the soil surrounding the base pier must be maintained in a stable and well compacted condition with the ground surfaces sloped away from the piers to provide adequate drainage. Ponding of water should never be allowed, since the structural stability of the pier

can be diminished and settlement or lateral movement may occur. Landscaping or the installation of surface or subsurface drains should be provided where ponding is a problem. Vegetation should not be permitted to grow in the vicinity of the tower base pier.

5. Ground Straps. At many towers, the base insulator rests on top of copper ground straps that are bonded to the ground system. This arrangement has caused severe galvanic corrosion of the steel base insulator plates. It has been established that the only bonding connection which is necessary between the base plate of the insulator and the grounding system is a single #8 AWG conductor. The most acceptable grounding arrangement at the base of a Loran-C tower is shown in Figure 5-8. The 6 inch ground strap can be installed around the top or side of the foundation pedestal in order to reach all ground-end ball gap arms. Existing straps beneath the base insulator may then be cut flush with the insulator plate, and corrosion may be arrested by cleaning the area and sealing it with a petroleum-based coating. It is necessary to ensure that the transmitter ground lead is connected to a portion of the ground radial system and not to the base insulator plate. However, if the grounded rod of the ball gaps is mounted on the base insulator plate, a larger conductor between the base insulator and the ground system is required; its size is computed as follows:

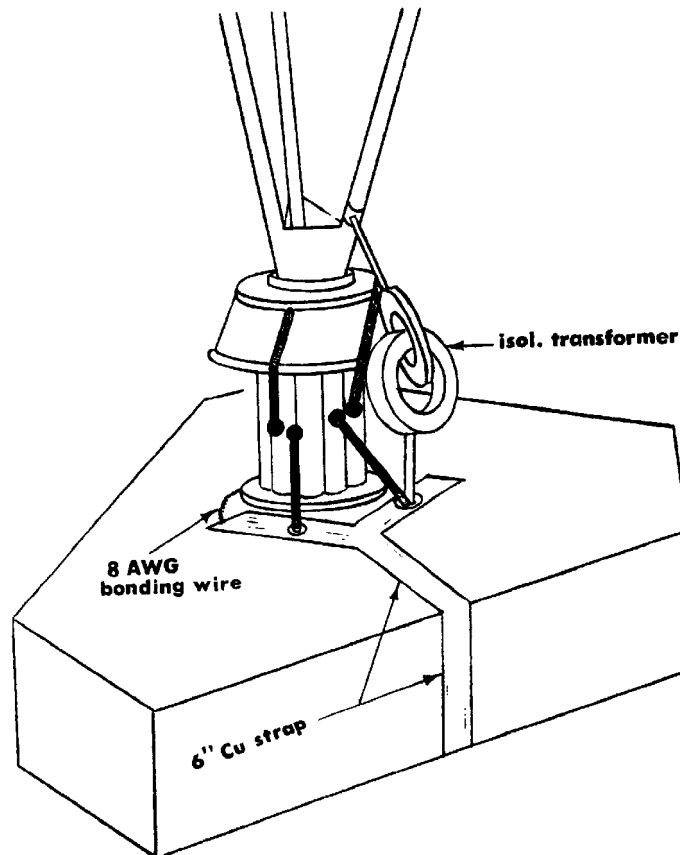

Figure 5-8 Grounding and lightning protection details at the base of an energized tower.

- a. Compute the projected area of one of the balls of the ball gap, in square inches. Call the numerical value of this area "M".
 - b. Choose a conductor whose perimeter, when viewed in cross-section, is equal to or greater than "M" when expressed in inches. The minimum recommended strap thickness is 16 gage.
 - c. For example, consider 1-1/2 inch diameter balls on a tower's ball gaps. The projected area is $\pi/4 \times (1-1/2)^2$ or 1.77 square inches. "M" = 1.77. Select a one-inch wide stainless steel strap as the base-insulator-to-ground-system conductor; viewed in cross-section, its perimeter is $1" + 1" + 2 \times (\text{strap thickness})$, whose numerical value is more than "M".
 - d. The stainless steel strap should then be bonded to the copper ground strap(s) a suitable distance from the base insulator where inspection and maintenance of this connection can be readily accomplished.
- F. Ladder Safety Rail, and Rest Platforms. These features require particular attention because of their relationship to the safety of climbers. The safety rail, ladder, rest platforms, and all associated connections should be carefully inspected for corrosion, breaks, looseness, etc. The safety rail should be inspected to ensure that the rail sections have been installed right-side up (that the notches are at the bottom of the tapered cuts rather than at the top) and for worn, broken or defective notches. Replace defective rail sections as soon as possible. Ensure that Safety Rail (or any fixed ladder safety system) is properly supported and fastened at the minimum intervals specified by the manufacturer. Climbing devices should be visually inspected for cracks before each use. Safety rails should not be painted unless corrosion is a serious problem. The use of stainless steel safety rails is recommended in corrosive environments to reduce maintenance. Paint or coatings applied to ladder rungs should not have a smooth or glossy finish in order to reduce the possibility of slipping while climbing. The clamps, studs, bolts, and nuts used to secure the safety climbing rail should be inspected for corrosion, looseness, and breakage, and should be repaired or renewed as appropriate. Replacement studs, nuts and bolts should be stainless steel.
- G. Hoists and Elevators. Originally, many 625 and 1350 foot towers were furnished with hoists, and several 1350 foot towers were furnished with elevators. Due to their infrequent use and the high degree of inspection and maintenance required to keep them safely operable, they are no longer specified for new towers. Although most of the hoists, motors, controls, and elevators have been removed from existing towers, some elements of the system such as pulleys, fair leads, cab rails, and platforms have been retained to facilitate inspection and maintenance.
- H. Ground Systems. Most antenna towers and antenna support structures must be properly grounded to maintain proper electrical and counterpoise characteristics for the antenna. Loran tower ground systems consist of copper wire radials bonded to tubing or screen and extending outward from the tower base toward the tower guy or radial anchors. Depending on the type of antenna and the type of soil conditions involved, radial ground wires will be required every 1 to 4 degrees in a full circle around the tower base. The ends of the ground wires may be brazed to individual

ground rods, which are embedded into the earth to prescribed depths. The tower base pier is normally grounded as are the guy anchor arms. Ideally, the radial ground system should be shallowly buried for electrical stability and to prevent damage from vehicles and equipment. In many locations, however, ground systems have been placed above ground, and fastened at various intervals with stakes or pins to keep the wires in place. Ground wires, leads, and connections should be maintained in their design condition. Wires above grade should be inspected for breaks or looseness, and repaired by brazing or by splicing in new sections as appropriate. Exothermic welding of ground connections provides a better bond, but is not very practical except during initial installation of the ground system. Special mechanical fasteners are available for ground connections and will give satisfactory results if they are properly sized and installed.

- I. Tower Jacking Legs. Jacking leg or frames have been provided for some towers for use in connection with initial erection and with replacement of the base insulators. These items should be inspected periodically and maintained in good condition to permit their use when required.
- J. Spare Parts. Whether through initial outfitting or subsequent procurement, a variety of structural and electrical spare parts are available for each tower or antenna system. Typical parts are hardware or expendable items such as turnbuckles, Big-Grips, light bulbs, nuts, bolts, mercury switches, and johnny-ball insulators; sometimes major items such as tower members and base insulators are stored at the station.
 1. Identification. All tower spare parts must be carefully identified and maintained in like-new condition. The servicing CEU should ensure that station personnel can accurately identify each spare part by attaching tags, providing detailed descriptions, or whatever other method may be most appropriate. Any item that is in questionable condition should be discarded.
 2. Inventory. An accurate inventory of all tower spares should be available at the station and in the office of the servicing CEU. This inventory should be updated periodically by responsible station personnel. Local experience should dictate detailed spare parts requirements, based on station isolation, long lead-time items, and probability of failures.
 3. Storage. Tower spare parts should be stored in a specially designated location at every station, and access to this area should be strictly limited. Items which may be adversely affected by exposure to weather should be stored indoors. A central storage area, within the servicing CEUs jurisdiction, may be justified for common heavy or expensive tower spares.
 4. Procurement. It is recommended that all major tower part procurements be coordinated by the servicing CEU. The station may be made responsible for procuring minor electrical system items such as lamps and mercury switches. Certain long lead-time items such as isolation transformers may be in Coast Guard stock. However, many older base insulators are no longer manufactured. As a result, replacements for older base insulators may require custom fabrication by the manufacturer. In cases where custom fabrication of older base

insulators is not possible, a tower engineer should determine which base insulator currently being manufactured is appropriate to replace the older insulator.

- K. Antenna Installations. The installation of antennas, mounting brackets, and feed lines on towers add to the sail area of the structure. For every tower, there is a limit to the amount of sail area that can be placed on a tower to avoid overloading it in high wind or ice conditions. This allowable limit shall be checked prior to the installation of antennas on towers. Consult the servicing CEU for verification that it is safe to install the proposed equipment. At a minimum the following information is required:
1. Tower Model and height.
 2. Existing antenna configuration with flat plate equivalent areas and surface areas for existing antennas and mounting brackets. The flat plate equivalent area and surface area are typically available from manufacturer's technical data.
 3. Manufacturer's technical data for the proposed installation including the antenna, mounting bracket, feed line and location on the tower.
- L. Antenna Removals. The removal of existing antennas that are no longer needed is required to minimize loads on towers during storm conditions. The removal should include the antenna, mounting bracket, and transmission line. Notify the servicing CEU and the cognizant ESU in the event of an antenna removal.

CHAPTER 6. GUYS AND GUY ANCHORS

- A. General. A wide variety of materials are used in guy supports for towers. This chapter is devoted to hardware specific to guyed towers including, guy cable, guy hardware, insulators, and anchors. It outlines their most important characteristics and inspection and maintenance requirements. This chapter will also provide instruction on the procedure for designating guy lanes, guy levels, and anchors.
- B. Standard Guys, Guy Anchor and Insulator Designations. The following conventions shall be used to designate tower guy anchors, guy lanes, guy levels, and guy insulators. The use of these conventions is very important to avoid confusion in inspection reports and correspondence. This section provides information on guy and anchor designations only. Conventions for the designation of tower legs and faces are provided in Chapter 5 of this manual.
1. Guy Lanes. Guy lanes are designated "1", "2", and "3" starting with the first lane clockwise from the North. There are normally three structural guy lanes for a guyed tower and up to 24 lanes when designating top loading radials of some Loran-C towers (Figure 6-1).
 2. Guy Anchors. Anchors are designated by a letter and number. The anchors nearest the tower are designated "A", the next farthest "B", and so on. Anchors are also designated by the "guy lane" that they are in (Figure 6-2).
 3. Guy Levels. Guys are designated by a number according to the tower attachment level and a letter if the tower is faced-guyed. Tower attachment levels are numbered consecutively from the lowest level up. The letter used for face-guyed towers is either "A" if it is the left hand guy when looking at the tower from the anchor, or "B" if it is the right hand guy (Figure 6-2). Top loading radial guys receive the same designation as their anchors, since only one guy is attached to each anchor and there can be no confusion. For example:
 - a. "4-B2" is the guy leading from the 4th guy level attachment point to anchor B in guy lane 2, on a corner-guyed tower.
 - b. "3B-A1" is the right hand guy leading from the 3rd guy level attachment point to anchor A in guy lane 1, on a face-guyed tower.
 - c. "C13" is a radial guy that is the 13th such guy clockwise from North. Note that "C13" is also the proper anchor designation.
 4. Multi-Tower Antennae.
 - a. SLT Antennae. View the antenna field in plan, and consider the feed point as the center of the system. The first tower clockwise from North is "Tower #1", the next clockwise is "Tower #2", etc. SLT antenna panels are designated by two digits according to their support tower numbers; for example Antenna Panel 2-3 is supported by towers #2 and #3. "Antenna Panels" refer to the energized antenna wire arrays, and should not be

confused with "Tower Panels" discussed in Chapter 5 ►B.4.

- (1) SLT and TIP Guys do not follow the convention established in ►B.3 above for their designations. Guy lanes are designated "A", "B", or "C", depending on their position relative to the antenna system, rather than in reference to North:

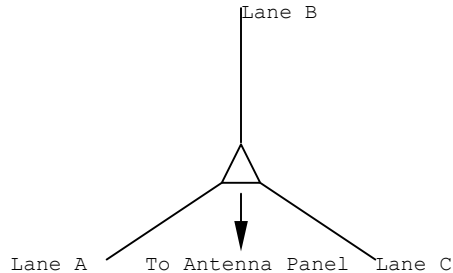

- (2) Each guy is then designated by (a) pull-off elevation, (b) lane, and (c) tower number. For example, guy "7-B-TWR#2" is the seventh-level guy in lane "B" at Tower #2.
 - (3) SLT and TIP Anchors. The anchors nearest the tower are designated "A", the next farthest "B", etc. This letter, plus the lane designation, plus the tower number will identify a particular anchor. To avoid confusion, the word "lane" should be used with the lane designation. For example, "B-lane C - TWR#3" is the anchor second farthest from tower #3 in lane C.
- b. Log-Periodic Antennae (LPA). In an LPA, the Northernmost tower is "Tower #1", the Southernmost tower is "Tower #2". Where there is more than one LPA at a particular station, local practice should be used to designate each LPA. Guys and anchors of LPAs should be given designations in accordance with Section B above.
5. Guy Insulators and Segments.
- a. 1350-ft. Loran-C Towers. These towers have insulators in a "cluster" at the tower connection points (designated "CL") and distributed along their guys as "break-up" insulators (designated "BU"). The insulators are numbered from the tower downward, beginning with "1CL" for the first cluster insulator and "1BU" - for the first break-up insulator. Thus, "3-B2-4CL" is the 4th insulator in the cluster in guy 3-B2.
 - b. Strain Insulators. Ceramic and fiberglass insulators whose insulating element is in tension are generally known as "strain insulators". Since there is usually only one strain insulator per guy, the designation is "Strain Insulator, Guy _".
 - c. All other insulators are numbered from the tower downward (ignoring the presence of strain insulators), and designated according to this number and the guy in which they are located. Thus, "3A-B3-4" is the 4th insulator down from the tower in guy 3A-B3.
 - d. Guy Segments. Guy segments are designated according to the guy in which they are located and are numbered from the strain

insulator downward. Thus, "3A-B3-4" is the 4th segment down from the strain insulator in guy 3A-B3. It is also an insulator designation (see previous paragraph), but the context of the message, report, etc. should make it clear that it is a segment being discussed. Top-loading elements above the strain insulator are designated "TLE (guy #)".

- C. Guy Cables and End Fittings. Steel cable used for tower guys and top loading elements are zinc-, aluminum-, or copper-coated wire arranged in the form of strand or rope. Guy cables serve to provide lateral support for the tower and are an integral element in the structural system. Cables are selected on the basis of their rated breaking strengths. In accordance with EIA/EIA-222-(series), for structures under 700 ft in height, the safety factor of guys and their connections shall be not less than 2.0. For structures 1200 ft or greater in height, the safety factor of guys and their connections shall not be less than 2.5. For structures between 700 ft and 1200 ft in height, the minimum safety factor of guys and their connections shall be determined by linear interpolation between 2.0 and 2.5 (Note: A 1/3 increase in stress for wind-loading conditions does not apply to the published breaking strength of guys and their connections. In addition, cables used as antenna elements are selected for electrical characteristics. When specified, cable and end fittings are proof-tested and pre-stressed before being placed in service. Pre-stressing is normally a requirement for larger cable sizes used on taller towers in order to remove constructional looseness.
- D. Wire Strand and Rope. Wire strand is composed of individual wires laid helically about an axis or center wire that produces a symmetrical cross-section. Wire rope consists of strands (each made up of several wires) laid helically around a center strand. The direction of rotation or helix of either the wires in a strand or the strands in a rope is termed "lay". Wires spiraling towards the left or right are denoted as left hand lay and right hand lay, respectively. Strand is less flexible than wire rope, has a higher modulus of elasticity, and size for size is stronger by about 30 percent. That strand is less expensive than rope accounts in part for its extensive use for tower guys. There are also major differences in the types of wire strand and wire rope. Primary classifications for strand are Steel Strand and Bridge Strand, and for rope are Wire Rope and Bridge Rope. Appendix C provides cable data including tabulations of sizes, grades, and strengths.

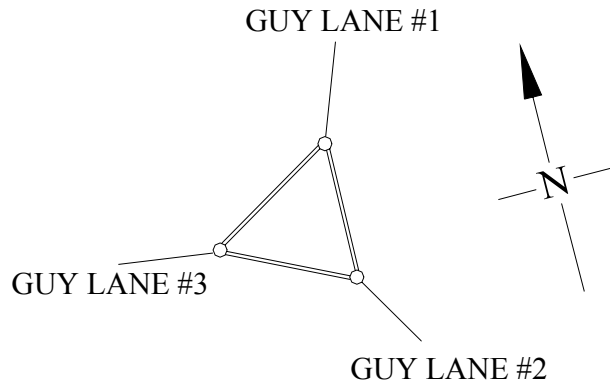

CORNER GUYED TOWER

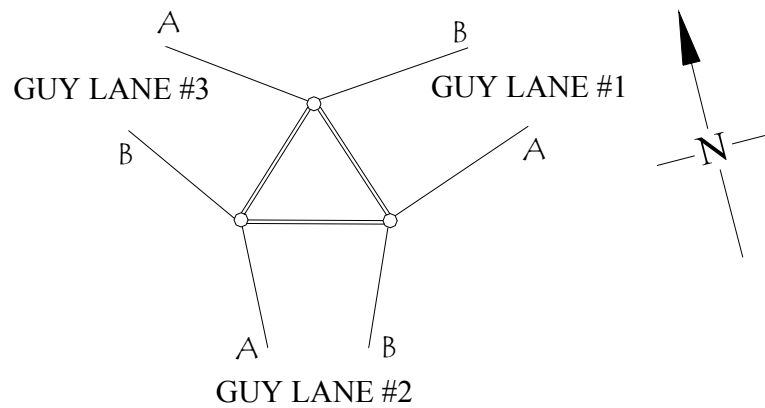

FACE GUYED TOWER

TOWER GUY LANE DESIGNATIONS

Figure 6-1

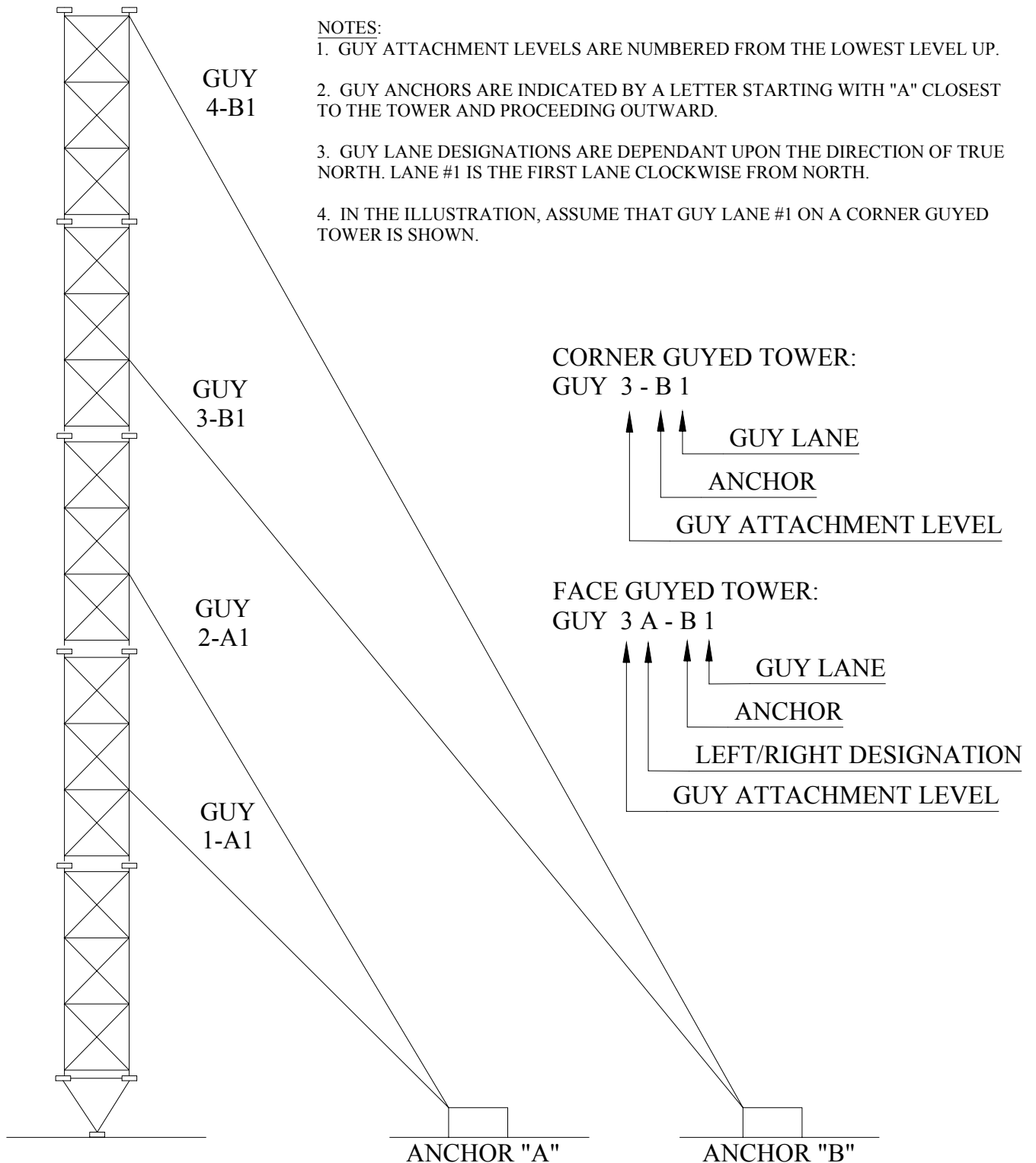

TOWER GUY AND ANCHOR DESIGNATION

Figure 6-2

- E. Galvanized Steel Cable. The individual steel wires are coated with zinc, which is either applied electrolytically or by the hot-dip process in accordance with ASTM A475 or A586. As in the case of galvanized steel shapes, the purpose of the coating is to provide corrosion protection of the steel wires. The weight of the zinc coating is specified as Class A, B, or C, which designates the coating weight in ounces per square foot of uncoated wire surface. A hot-dip process results in a Class A coating thickness. Class B and C coatings are applied electrolytically and have double and triple the mil thickness of a Class A coating, respectively. The catalog breaking strength of bridge strand and rope is usually based on a Class A coating of the individual wires. It is standard manufacturing practice to provide galvanized cable with all wires having either a Class A, Class B, or Class C coating on the outer wires and a Class A coating on the inner wires. The theory of applying a thinner coating of zinc on the inner wires is that they are protected from the corrosive elements by the outer wires of the cable. As the thickness of the zinc coating on the individual wires increases from Class A to Class C, the diameter of steel wires which make up the cable decreases to compensate for the addition of the peripheral zinc coating so as to maintain the standard catalog nominal diameter of the strand or rope. For corrosive environments, Coast Guard practice is to call for Class C galvanizing on all inside and outside wires. When other than Class A galvanizing for the inside and outside wires is required, the manufacturer must be consulted on the adjusted minimum breaking strength of the cable.
- F. Aluminum Coated Steel Cable. This type of cable is made up of high strength steel wires covered by a coating of aluminum. The wires are arranged in the form of a single multi-wire strand. The coating is applied by either the hot-dip method (ASTM A474) or by a powder metallurgical process (ASTM B415 and B416). "Alumoweld" is a common cable manufactured to these specifications. The advantages of aluminum coated steel cable are its high degree of corrosion resistance and its high strength to weight ratio. However, the use of this type cable may be limited because of size limitations.
- G. Reinforced Aluminum Conductors. This type of cable is furnished in the form of multi-layered strand in which the inner core wires are made of either galvanized steel or aluminum coated steel with the outer wires made of solid bare aluminum wire. This strand is often confused with aluminum coated strand such as Alumoweld. The basic application for this cable is as open wire conductors where the combination of strength and conductivity are required. It has been used extensively for the top loading elements of Loran-C towers. The galvanized steel wire for the core of aluminum conductor, steel reinforced (ACSR) strand is furnished to ASTM B498, which covers various weights of the zinc coating, such as Class A, B, or C. The aluminum conductor is furnished to ASTM B230 and the completed strand to ASTM B232. Cable with a core of aluminum-coated steel wires is known as ACSR/AW. Another somewhat stronger variation of ACSR cable is Alumoweld-Aluminum Conductor (AWAC). A specially designed Big-Grip type connector is usually specified for all these cables. Several problems have occurred, however. The ACSR solid aluminum outer conductors have broken at the press fittings which in some cases led to slippage and loss of a top-loading element. Brittle and/or stress failure of the solid aluminum wires has occurred and can be expected to occur with time. For these and associated reasons, ACSR, ACSR/AW, AWAC or any other type of strand which consist, in part, of solid aluminum

wires are no longer recommended for Coast Guard use. Whenever replacement of existing guy or antenna cables of this type is indicated or required, Alumoweld cable should be used.

- H. Copper Coated Steel Cable. This type of cable is made up of steel wires covered by a coating of copper and arranged in the form of a multi-wire strand. The strand is available in a wide range of sizes, strengths and degrees of conductivity. The coating process is achieved by pouring molten copper into a mold containing a heated steel billet, which unites the copper and steel. The resultant product is then hot-rolled to rod size and then cold-drawn into finished wire sizes. The thickness of the copper coating varies with the size of the wire. The coated wire is furnished to ASTM B227 and the completed strand is furnished to ASTM B228. Copper coated steel wire strand has slightly less strength than an equally sized strand made up of aluminum coated steel wire, and is also more expensive. This type of cable has been used for structural guying on 625-ft. towers. The copper coating provides excellent corrosion protection because of its nobility. However, if the coating is nicked or scratched to the extent that the underlying steel is exposed, the steel will sacrifice itself to protect the more noble copper coating (in much the same way that zinc will sacrifice itself to protect steel), resulting in the loss of the structural cross section of the cable. This disadvantage is inherent in the use of copper-coated steel cable for tower structural guys, and more frequent corrosion control inspections are required. This type cable is not recommended for Coast Guard use.
- I. Cable End Fittings. Terminals for the various types of guy cables previously discussed are factory applied compression (press type) fittings, sockets, and pre-formed Big-Grip dead-ends. These end fittings are designed to have a holding efficiency equal to or greater than the catalog rated strength of the cable to which they are applied. Cable clips are less efficient, and consequently are not authorized for any new structural application. See Appendix C for illustrations of end fittings.
1. Compression Fittings. Compression or press type fittings are generally applied to guy cables under one inch in diameter. They are normally applied by the tower fabricator. They consist of a sleeve that is applied to the live and dead ends of a cable looped around guy strain insulators or thimbles. These fittings are generally made of copper, aluminum or stainless steel alloys compatible with the surface material of the cable to which they are applied. Compression end fittings having a forged clevis or eye for connection purposes (in lieu of forming a loop as described above) are referred to as swaged fittings. These are commonly used on smaller antenna arrays, mostly with stainless steel cable.
 2. Socket End Fittings. Open and closed end sockets are used for the larger cable sizes (usually over one-inch in diameter), particularly on bridge strand and rope where high strength end fittings are required. These sockets are usually made of galvanized carbon steel and are forged and machined. The open socket has a clevis pin connection, whereas the closed socket has an eye pin connection. Socketing is accomplished by inserting the separated strand or rope wires into the cone shaped basket of the socket. The socket is then heated and molten zinc is poured into the basket to form the high strength connection. This type of socket end fitting is also

referred to as a potted fitting. In recent years, epoxy has been used to fill the socket basket in lieu of zinc. This method allows for socketing in the field in emergency situations where a molten zinc pot is not available. Although this method is also used by the cable manufacturers upon request, the process requires much more quality control than zinc filling and is not recommended when zinc filling can be performed.

3. Preformed Line Products Big-Grip® Dead-Ends (BGDEs). BGDEs (often referred to as a PLP's or dead-ends) are a commonly used end connector. BGDEs is a proprietary product manufactured by the Preformed Line Products Company. The BGDE is helically laid over the main cable; the greater the pull the tighter the clamping action of the dead-end. See Appendix C for product information. The inside of the BGDE is coated with an abrasive that is suited to the material of the cable being gripped. The dead-ends are made of the same material as the strand or cable to which they are applied, including high strength steel wires that are coated with aluminum, zinc, or copper depending on the coating of the main cable. The lay of the BGDE must match the lay of the main cable. When ordering any Preformed Dead-End, it is very important to specify the type, size, and lay of the main cable, and the intended use of the dead-end if not as an end grip or as noted in ►H.3.a below. If it is to be used with open or closed end porcelain insulators (johnny-ball), the type and size of insulator should also be carefully specified. Similar preformed products in use on Coast Guard antennae are "splices", for connecting two cables end-to-end, "armor rods" for protection of an area of a cable or for building up cable diameter.
 - a. Big-Grip® Dead-Ends for ACSR, AWAC, and ACSR/AW. Special double BGDEs are used for end connections of ACSR type cable. First the outer aluminum layers of the cable are cut back to expose the inner core wires. A small BGDE is then applied to grip these core wires. Armor rod is then applied (if necessary) over the smaller BGDE to build up the cross-section to that of the original main cable. Finally, a large BGDE is applied over the armor rod and extended over a few feet of the main cable beyond the cut-back point. The BGDE loops are then fitted with a single thimble, and the connection is ready.
 - b. Dead-end Installation. During the original installation of a dead-end on a cable, the BGDE may be applied up to three times in order to achieve proper positioning. If the proper positioning cannot be achieved in three applications, the BGDE must be discarded. If removal is necessary after a BGDE has been installed under load for a period greater than 3 months, the dead-end shall be replaced with a new one.
 - c. Use as a Pulling Grip. The use of BGDEs as an auxiliary grip for hauling a cable or removing the load from the permanent end connection is authorized, provided that the provisions in ►H.3.b above are complied with.
 - d. End Sleeves. Instances of BGDEs unraveling have occurred. After testing and analysis by the manufacturer, it was determined that icing and misapplication of the Big-Grips were the causes of

unraveling. Unraveling tends to occur only on BGDEs at the lower ends of guys, due to ice sliding down onto the BGDE legs. The effect of guy galloping and vibration was also studied, but results were inconclusive. As a preventive measure, the manufacturer developed a special "end sleeve", as shown in Figure 6-3, and suggested that these end sleeves be installed on all BGDEs. The end sleeve ensures that the Big-Grip remains properly applied as they prevent unraveling, discourage tampering, and break up and deflect any ice that may travel down the guy cable. When ordering end sleeves, carefully specify the part number of the dead-end, type of coating, and size of the main cable. A common sleeve design works with either lay. In an emergency, available sleeves of the wrong size may be used by crimping oversized sleeves or spreading undersized sleeves. It is Coast Guard policy to install end sleeves in the following situations:



Figure 6-3 End sleeve installed on guy-grip dead end.

- (1) Where the cable connected by dead-end extends for 200 feet or more without interruption, in either an upward or downward direction, where icing can occur.
 - (2) On ground level BGDEs at remote, unmanned sites.
 - (3) On any dead-end which, in the opinion of the servicing CEU, requires this added safety precaution.
- e. Unraveling. If unraveling of a dead-end, splice, or similar connector is observed, the urgency of replacement may depend on the position of the grip along the guy, the location of the tower, and the resulting cost and scope of work. Any unraveling should be reported to the servicing CEU. The following table gives estimates of the remaining strength in unraveled dead-ends and should be considered when scheduling repair:

<u># of pitches unraveled</u>	<u>% of rated strength remaining</u>
1	98
2	88
3	73

- f. Restriction in Use of End Fittings. Cable clip, U-bolts, line taps or similar manually applied hardware are less efficient than the aforementioned fittings and require frequent checking for tightness. They have been used in the past to some extent for dead ending guy cables on towers up to 625 feet in height. However, they are no longer specified for use in any structural application on tower guys. Their use is restricted to reducing the cable bight size around guy insulators when the cable is held by factory applied compression fittings, or for special, temporary purposes (such as in a splice or as shown in Figure 6-4) until a permanent fix is made.



Figure 6-4 "Sister Wire" consisting of shackles, turnbuckles, wire rope segment with preformed eye, reinforcing a TLE on a Loran tower.

- J. Inspection and Maintenance. Corrosion control is the most common and continuing inspection and maintenance problem for guy cable and end fittings. However, abrasion and complete breaks in the cables (particularly at the connection points of end fittings) can also occur. Structural guys have a built-in safety factor to compensate for loss of cross-sectional area of the steel wires of the cable. The amount of permissible loss and residual cable strength is impossible to determine when corrosion is the reducing agent. However, fairly accurate estimates can be made when one or more of the cable wires are broken.
1. Inspection. Tower guy cables are, for the most part, inaccessible and difficult to inspect. With the exception of bulging outer cable wires due to interior wire corrosion, the extent of any damage to the interior wires of the cable is practically impossible to detect without removing the cable from service. However, bulging of the

outer cable wires is difficult to detect and in many cases is not present. Wind induced vibration and rain frequently "washes away" the corrosion as it develops reducing the likelihood of bulging in the cable. However, staining can occur on the cable indicative of this type of corrosive action. The only known practical method (short of destructive testing) for determining the condition of any type of installed guy cable is by visual inspection of the outside of the cable. Indicators of cable condition are abrasion of the outside wires, broken outside wires (Figure 3-4), and corrosion. In extreme cases, a marked decrease in cable diameter can be an indication of severe abrasion of the outside wires and/or corrosion of the inside wires. Previous inspection reports and as-built drawings should be carefully consulted prior to taking action on any cables or wires evaluated solely on changes in diameter. If surface examination does not show evidence of corrosion, broken wires or abrasion, but the cable diameter is markedly reduced, a condition of internal deterioration or material failure may have taken place. In all such extreme cases, immediate corrective action is required. A reasonable guide to overall guy cable condition is a close examination of the guy cables that are accessible, such as the ground level. As a rule, examination of the exposed surfaces of guy cables will provide a fairly accurate indication of the cable's condition and the importance of periodic inspection is emphasized. Since guy cables are subjected to changes in stress, bending, abrasion and corrosion, any one of which can ultimately reduce strength, their condition can be expected to change. It is necessary, therefore to watch for these changes and maintain a record of cable condition so that any adverse trends can be determined. Whenever a broken cable wire is found, replacement or bracing of the involved guy segment must be considered. See Figure 6-4. The seriousness of such a condition is considered as being dependent on the number of sound wires left in the cable. In cases of this kind, the cause of the break should be determined, and the area of the break closely examined to see if there is any evidence of a pending failure of the other cable wires, such as necking down of the wire (reduction in section due to overstressing) or corrosion. If corrosion is found to be the cause, the chances are that the adjacent wires have been subjected to some degree of the same corrosion process (except in the case of "Copperweld"), and complete failure of the cable could be very close at hand. During tower inspections, the cables should always be closely examined at the end fittings, as it is at these points where abrasion, breaks, and corrosion of the wires will most likely occur. Any evidence of cable pullout or slippage of the end fittings should be carefully noted. The end fittings with their associated shear pins and cotter pins should also receive reasonable inspection coverage for corrosion, deformation, cracks and other signs of distress. The guidelines presented in Chapter 4 should be consulted for a discussion of the various techniques that may be employed to perform cable and end fitting inspections.

- a. Galvanized and Aluminum Coated Steel Cables. Zinc and aluminum coated steel cable will exhibit corrosion in much the same manner as galvanized steel and aluminum structural shapes. Chapter 5 ► C should be referred to for a discussion of the corrosion process as it pertains to zinc and aluminum. Special attention must be paid to ACSR cable, especially at the factory applied press end fittings where slippage or failure of the outer aluminum

conductors has been prevalent (see ►F above). A small mirror mounted on a short stick or pole will help to examine the lower portions of the end fittings at the tower end of the guys and TLE's. Another characteristic of ACSR cable is a tendency for the inner galvanized core wires to corrode, causing a bulging ("birdcaging") in the cable. Replacement should be considered if the bulging increases or the inner strands show significant wear or breakage. Sample testing to breaking load, if practical and feasible, may help to determine if and when replacement is justified.

- b. Copper Coated Steel Cable. Corrosion of copper coated steel wire cable presents a much different and more difficult problem than does corrosion of zinc and aluminum protective coatings. Copper is a noble metal and is not a sacrificial coating as is the case of zinc and aluminum. It has a high degree of resistance to atmospheric attack. After exposure to the atmosphere, the copper coating oxidizes and slowly develops a thin, sometimes brittle, green to brown coating called patina. This coating is a copper sulfate and after many years of exposure becomes stabilized and undergoes no further change. This coating is more likely to develop on the copper surface in industrial and seacoast areas, and it serves as a protective coating. Since steel is anodic to the more noble copper, a fracture or pit in the copper coating which exposes the underlying steel will cause corrosion of the steel because the steel will sacrifice itself to protect the copper. Copper coatings provide a higher degree of protection against corrosion than is afforded by zinc and aluminum coatings, but only as long as the copper coating remains completely intact. Also, sometime after exposure, the copper coating may dull and approach the color of rust and it then becomes very difficult to distinguish the copper patina from any steel corrosion that may be present. Furthermore, if rusting is detected at the surface of the coating, the full extent of corrosion of the steel core cannot be visually determined. Inspection of copper coated steel wire cable should be directed to those portions where tensioning clamps, "come-alongs" etc., have been used, at the end fittings, and other areas where abrasion and wear may have occurred. During this inspection, the individual wires should be checked for surface irregularities such as pits, scratches, nicks, and loss of cross-section.
2. Maintenance. Maintenance of tower guy cables and end fittings is a difficult task, primarily from the standpoint of accessibility. This problem is discussed under Ch. 4 ►C.2 along with several suggested means of reaching the inaccessible portions of the guys. The most important guy cable maintenance item will be corrosion control.
 - a. Galvanized and Aluminum Coated Steel Cable. When rusting of zinc and aluminum coated steel wires or end fittings is detected, the affected areas should be reconditioned in accordance with the protective treatment procedures described in Ch. 7 ►E.3. This corrective action should always be taken as soon as possible after detection to minimize future inspection and maintenance attention. In certain instances, it may not be immediately possible to accomplish the necessary reconditioning. When this

happens, a delay can generally be permitted under two conditions: (1) where the extent of corrosion is limited to small and scattered rust spots (because they will continue to receive protection from the adjacent protective coating of zinc or aluminum); and (2) provided that frequent checks (including close-up color photographs if possible) are conducted to monitor the progression of the corrosion process. When a perceptible progression is detected, the protective treatment should be applied as soon as practical. There should be no delay in reconditioning rusted areas on cable or fittings that are readily accessible.

- b. Copper Coated Steel Cable. Maintenance of copper-coated steel cable and end fittings is not anticipated and is not recommended due to the inherent characteristics of this type of cable as discussed in paragraph I.1.b above. Repair in the form of cable and end-fitting replacement is the only reasonable recommendation that can be made. Any such replacement should be a different type of cable, preferably with aluminum coated steel wire.

- K. Guy Cable Hardware. Guy hardware items such as thimbles, turnbuckles, take up U-bolts (hairpins), link bars, and shackles with associated pins are important structural accessories which must receive the same degree of inspection and maintenance that is given to other guy structural components. See Figure 6-5. Guy hardware items are selected for their efficiency and reliability in the same manner as other structural components. Their factor of safety is commonly 4 to 5 (ultimate breaking strength/design load). Most hardware items are made of galvanized carbon steel.



Figure 6-5 Structural guy anchor on a 625ft Loran-C tower.

1. Thimbles. Steel thimbles provide a supporting grooved bed of ample radius and length to accommodate the cable and protect it from abrasion and distortion when placed under tension. Due to the importance of maintaining adequate cable loop radius, only heavy-duty type thimbles should be used for any guy application. Thimbles should be inspected for wear, deformation and corrosion at the same time the guys are inspected. Since galvanized steel thimbles are commonly used in conjunction with copper-coated steel cable, the areas of such dissimilar metal contact should be closely inspected and maintained. Evidence of wear and deformation should be carefully noted; extreme cases of either condition can cause the cable or Big-Grip to bend in a reduced radius which in turn can cause serious wear and fatigue problems at the area of contact between the hardware and cable or Big-Grip. Maintenance of thimbles will be limited to corrosion control. When wear or deformation of the thimbles occurs, replacement is recommended.

2. Turnbuckles and Take-up U-bolts. Turnbuckles are extensively used at the anchor end of the guy cables of towers up to 700 feet in height, and also at the anchor ends of the radial guys on some taller towers. Where higher strengths and versatility are required, take-up U-bolts (hairpins) are provided for use with closed end bridge sockets. These high strength-adjusting devices are installed at the anchor ends of all structural guys on some 280 to 300 foot single-guy-level tower guys. These devices are installed for the primary purpose of adjusting guy tension. They have extensive threaded areas that are highly susceptible to corrosion and damage. These hardware items should be inspected at the same time the associated guys are inspected. Evidence of wear, cracks, and deformation should be closely noted. To simplify minor guy tension adjustments, turnbuckles should be set with a 40-60% take-up during initial installation, guy replacement or whenever they are disconnected from the turnbuckle. Full opening or closing of turnbuckles should be avoided. For example, at least two or three threads of each threaded end should be visible within the body of the turnbuckle when open. Turnbuckles should be secured with safety wiring, locknuts, or other means to prevent rotation. Acceptable methods of safety wire installation are shown in Figures 6-6a and 6-6b. Lock nuts are used to prevent loosening of take-up U-bolts, and are the preferred securing device. The tightness of these devices should be regularly inspected. The jaws should be examined for deformation and cotter pins and other hardware should be checked for condition. The threaded portions of these hardware items should be maintained in such a condition that adjustments can be made as required. This can be accomplished by keeping the threads lubricated and corrosion free. When the turnbuckles or take-up U-bolts are found to be deformed, cracked, or in otherwise questionable condition, they should be replaced.

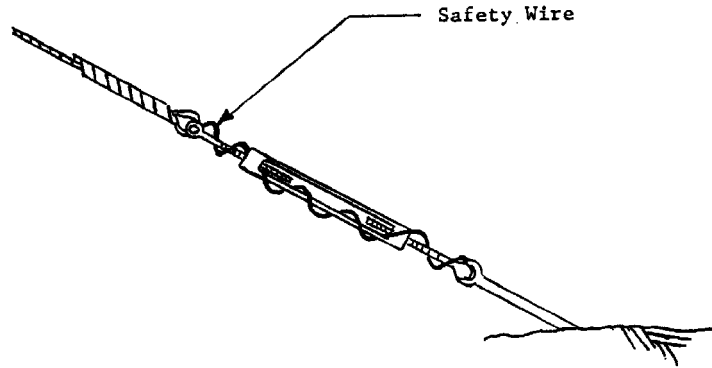

Figure 6-6a

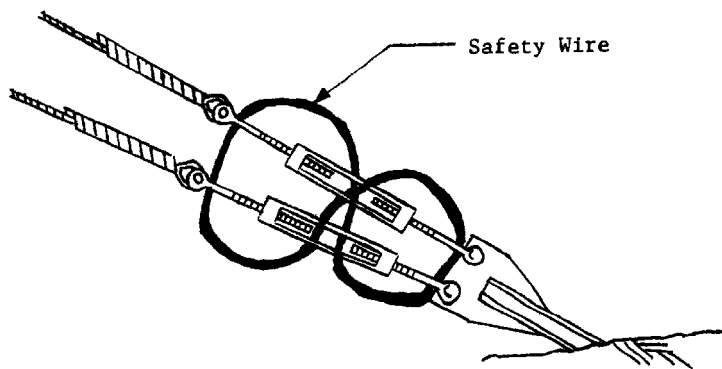

Figure 6-6b

3. Shackles and Pins. Galvanized steel shackles are used extensively on towers up to 700 feet for connecting guy end fittings and fiberglass insulator yokes to tower leg pull-off plates. They are usually forged from carbon steel and are formed with eyes at the ends of the legs for inserting a pin or bolt. Round pins held in place by cotter pins are most commonly used. Safety shackles are fitted with a threaded bolt, which is secured and held in place with a nut and cotter pin. Safety type shackles are preferred and should always be specified when shackles are replaced, especially at connections where vibration can accentuate pin movement. Shackle pin-to-turnbuckle pin connections should be avoided. Screw pin shackles in which the pin is screwed into a tapped eye of the shackle body are not recommended because of the lack of any positive locking feature. If used, they should be moused with safety wire to prevent loosening. All shackle elements including the body, pin, nuts and cotter pins, should be inspected at the same time as the other guy elements. Attention should be given to the shackle pin to make sure it is in proper position and that the cotter pin is providing the required locking action. For unthreaded shackle pins, whenever possible, ensure that the shackle pin head is snug against the shackle as this will eliminate cotter pin chafing. Any evidence of wear, deformation, and corrosion should be noted. Excessive wear and any degree of deformation are cause for immediate replacement. See Figure 6-7. Excessively corroded elements should be replaced promptly. Type 304

stainless steel cotter pins should be used on all shackles and shear pins. Galvanized or aluminum cotter pins normally corrode, wear, or break much sooner than stainless steel cotter pins. Standard shackles and other fittings usually come with galvanized cotter pins. Orders for new hardware should specify stainless steel cotter pins.

4. Bonding Hardware. In some cases, bonding straps have been installed across guy end fittings, shackles, etc., to provide electrical continuity and eliminate arcing. The straps are usually made of braided or solid copper or aluminum and are attached to guy cables, insulator yokes and tower members with various types of copper, aluminum and galvanized connectors. The use of metals with different potentials is sometimes unavoidable and a galvanic couple usually results. Aluminum-to-zinc couples do not present a galvanic problem, whereas copper to zinc or aluminum can be expected to cause varying degrees of galvanic corrosion. The materials involved can be readily identified and the zinc or aluminum metals in contact with copper should be closely inspected for evidence of corrosion during every guy inspection. Due to winds and vibration, the bonding straps may be broken at their connections and cause arcing.



Figure 6-7 Wear of cotter pins.

- L. Insulators. Loran and other towers that are radiating antennae are insulated from the structural guys with various types of insulators. The radiating top loading elements of Loran-C towers are insulated from their supporting guys. The support guys of these towers are divided into segments by what are called break-up insulators, to minimize RF noise. The insulating elements of the antenna and guy insulators are made of porcelain and or fiberglass. Some antenna and guy insulators are made up

entirely of porcelain, and others incorporate hot-dip galvanized steel supporting elements. Some antenna and guy insulators include gradient cones and arcing rings (see ►L below).

1. Porcelain Insulators. For Coast Guard use, porcelain insulators are manufactured by the wet process in which wetted clay is shaped by hand machine and then fired and glazed. Porcelain has extremely high compression strength (eight to ten times its strength in tension) and, consequently, most porcelain insulators are loaded in compression. Porcelain, however, is sometimes used in direct tension for the strain insulators at the ends of top loading elements where their tensile strength is adequate.
 - a. Open and Closed End Insulators. These types of guy insulators are used on towers up to 1350 feet in height where their mechanical and electrical properties are adequate. They are furnished in a wide range of shapes and sizes, and are commonly known as "johnny balls". See Figure 6-8a and 6-8b. They are made entirely of porcelain with holes or grooves at right angles to each other through which guy cables are looped in an interlocking fashion. Interlocking of the guy cable loops provides a fail-safe feature. The units with holes are called closed end insulators and the grooved units are called open-end insulators. Closed end insulators can be furnished with a rated mechanical strength up to 33,000 pounds and open-end insulators up to 140,000 pounds. Open-end insulators are stronger than closed end insulators for a given cable size, but have lower flashover ratings. Therefore, the flashover rating as well as the structural strength must be considered when interchanging one type for another during replacement or modification. These insulators have a small unglazed surface which, although watertight, is liable to collect contaminants and is therefore installed facing down the guy so that the insulator will stay clean. When ordering, two coats of varnish or weather resistant enamel should be specified to cover the unglazed portions. The glazing color should be specified brown to facilitate visual inspection. These types of insulators are normally selected on the basis of the same safety factor as the guy. Although they are a standard commercial product, procurement lead times of six months or more are normal.
 - b. Compression Cone Guy Insulators. This type insulator is designed to take advantage of the high compressive strength of porcelain. They are furnished in several different designs but basic features are similar. The major portion of the insulator consists of a cast steel open frame with a clevis connection formed at the top; a steel-capped, hollow truncated-cone-shaped porcelain dielectric is cemented to a circular seat formed at the bottom of the frame. Sometimes the porcelain cone surface is grooved to increase the leakage distance. See Figure 6-9. To complete the insulator assembly, the top end of an eyebolt is inserted through the porcelain cone where it is secured at the steel cap by split rings or a half round ball nut, depending on whether the top of the eyebolt has an upset head or threaded stub. The assembled insulator is connected to the guys through the clevis connection at the top of the frame and the eye of the eyebolt on the bottom. This type of insulator has a designed fail-safe feature in that the round steel cap on top of the

porcelain cone is larger in diameter than the circular opening at the bottom of the frame. Should the porcelain cone break, the metal cap and frame will engage to provide structural continuity in the guy system. The fail-safe feature of this type of insulator has not been fully tested either while in service or under laboratory conditions. In addition, the single solid eyebolt shaft is not fail-safe and, should the eyebolt fail, the guy will separate. Use of compression cone insulators is not recommended. In 1964, two 1350 foot Loran-C antenna towers collapsed either directly or indirectly as a result of eyebolt failures. Compression cone insulators used in the guy system of the replacement towers had special stainless steel rocker assemblies installed between the eyebolt head and the insulator cap to reduce the eyebolt bending stresses at the head-shank transition. See Figure 6-9. Precipitation hardened stainless steel (17-4PH) was employed for the towers at Cape Race, Sandur, Port Clarence, and Marcus, whereas AISI type 420 stainless steel was used for the rockers on the Yap and Iwo Jima towers. In 1966, cracks were discovered in the rockers on the Yap and Iwo Jima towers. An extensive study by Battelle Memorial Institute (BMI) led to the replacement of the 75 rocker assemblies in the upper three structural guy levels of the Iwo Jima tower. The BMI study recommended a new rocker material, inconel alloy 718, because of its higher resistance to stress corrosion cracking. In 1976, the rocker assemblies on the radial guys and on the 1st and 2nd guy levels of the Iwo Jima tower were replaced with inconel alloy 718 rocker assemblies. Special attention must be given to these eyebolts and rocker assemblies during inspection. Riding of selected guys on towers with eyebolt and rocker assemblies is not recommended because a guy could fail at any time without warning. The Tall Tower Coordination Center should be contacted before any repair or procurement action is taken relative to eyebolts and/or rocker assemblies to ensure that current design standards and optimum replacement materials are used.

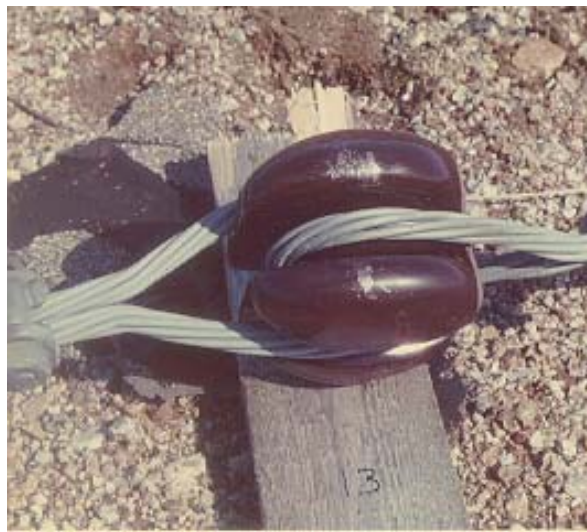

Figure 6-8a Open end johnny ball insulator.



Figure 6-8b Closed end johnny ball insulator.



Figure 6-9 Compression cone insulator.

- c. Porcelain Strain Insulators. This type of insulator uses porcelain in tension. It consists of a solid porcelain rod with metal caps cemented to each end. Guy cables are connected to an eye or clevis fitting formed on the metal cap. The diameter of the rod determines the tensile strength of the insulator and the rod length determines its electrical properties. To satisfy the electrical requirements, the rod may be grooved at regular intervals to form skirts or petticoats that increase the leakage distance along the length of the insulator. Because of the large size of porcelain required, the insulator is furnished in three segments, each with cemented metal caps for connecting the elements together and for attaching the guy cables to each end of

the assembly. These insulators do not have a fail-safe feature and consequently are designed with a safety factor of 2.5 or more. This type insulator is furnished by special order, and is not a readily available commercial line product.

- d. Fiberglass Loop Strain Insulators. This type of insulator uses a multi-filament continuous fiberglass loop in tension. A ceramic shell covers the fiberglass loop to provide protection from ultraviolet rays. The void between the ceramic and fiberglass is filled with insulating oil to prevent lightning from puncturing the ceramic. (If the void contained air rather than oil, lightning would tend to puncture the ceramic shell and follow the path of least resistance along the inside of the shell.) The oil is contained by a number of cork and neoprene seals and gaskets that are held in place by a spring. The fail-safe features of this insulator are the multi-filament loops. A fabrication effort of six months can be expected.

- e. Inspection and Maintenance of Porcelain Insulators. Insulators require periodic inspection for cracks, broken elements, corrosion of their metal parts, and contamination of the glazed surfaces of the porcelain elements. Generally, corrosion and contamination control will require the most inspection and maintenance attention. Most guy insulators are difficult to inspect and maintain because of their location. The guidelines presented in Chapters 3 and 4 should be consulted for a discussion of the various methods to follow in performing inspection and maintenance of guy insulators.
 - (1) Inspection. The porcelain insulator elements in current use have provided reliable structural service even after they have developed cracks or become chipped. Such conditions may, however, reduce the dielectric effectiveness of the insulator. Cracks or other structural damage to the porcelain elements should always be considered serious and inspection should strive for their early detection. Evidence of arc-over can be an indication of cracks in the porcelain elements. In oil filled insulators, oil leaks can also be indicative of cracks in the elements. Strain type porcelain insulators should be checked for any substantial loss of cross-section due to chip outs, The joints between the porcelain and end fittings should be checked for tightness. The bolted connections of multiple element strain insulators should be checked for loose bolts and nuts. The metal parts of the insulators should be inspected for corrosion and evidence of wear, deformation and other signs of distress in accordance with Ch.5 ► C.5. The porcelain elements should always be inspected for surface contamination. The ends of johnny-ball insulators near cable loops should be checked for chipping and fractures. Arc-over, particularly during moist conditions, can be indicative of surface contamination of the porcelain elements. Deterioration of the porcelain surface glaze can occur in some atmospheres and a dulling of the porcelain surfaces should be noted during inspections; such a condition will probably be progressive and ultimately result in a loss of dielectric efficiency.

(2) Maintenance. Porcelain insulator elements will require little, if any, structural maintenance. Chipped (but otherwise structurally adequate) guy insulator porcelains can be continued in service as long as there is no electrical problem. The chipped areas should be ground with an abrasive stone to remove all sharp edges and the affected areas should then be painted with weather-resisting gloss enamel. Whenever the cross-sectional area of a guy strain (tension) porcelain insulator is substantially reduced due to damage, prompt replacement is required. Metal parts of insulators should be maintained as indicated in Ch.5 ► C.5. Contamination on insulator porcelains should be washed or wiped whenever arcing across the insulators becomes problematic. Buffing the porcelain surfaces after an application of a very thin coat of silicone grease has been found to be effective in preventing contamination flashovers in some areas. A solution for extreme cases is to install insulators with higher flashover values.

2. Fiberglass Insulators and Non-Metallic Guys. Fiberglass rod insulators have been used extensively on 625-ft. Loran-C towers since 1961, and more recently on 700-ft. towers and multi-tower antennae. The long, thin rods have high dielectric strength and give good electrical performance; they are very strong in proportion to their weight and therefore desirable as structural members. Fiberglass rods are used where a radiating element must be connected with a grounded guy or tower. The rods are usually about 15 feet long, are installed in yoked pairs, and they are designed to a factor of safety of 5. Their structural capacity is limited by the bond strength of the end fittings (clevis). Other Coast Guard applications of synthetics include Phillystran support guys for several smaller towers, and stranded fiberglass rope for antenna support components and side catenaries on log periodic antennae. Use of synthetic cable material on a tower previously guyed by metallic guys substantially affects tower response. Prior to the use of synthetic guys, the tower and guy manufacturer should be consulted. Specifications held by the Tall Tower Coordination Center should be used when procuring new or replacement fiberglass rods.

a. Preventing Bending in Fiberglass Insulators. Two 300-ft towers at Communication Station Miami collapsed during a hurricane in 1992. On these towers the clevis end of the fiberglass rod insulator was attached directly to the pull-off plate. It is suspected that these towers experienced large lateral guy motion, possibly combined with opposing twisting motion of the mast. It is likely that this motion combined with the fact that the clevis was attached directly to the pull-off plate caused the tension rod insulator to experience bending forces and break. To prevent this, it is recommended that a shackle be installed between the clevis end of the rod insulator and the pull-off plate to provide for a "universal joint" at the tower connection.

b. Characteristics of Fiberglass Rods.

(1) Creep and Fatigue Resistance. Creep is a measure of long-term behavior under constant load. Fatigue resistance is a measure

of strength under cyclic or vibratory loading. Testing under laboratory conditions and some field results indicate that the performance of fiberglass rod is acceptable; however, fiberglass rope has high creep and low resistance to fatigue compared to metallic guy material, and is not recommended for structural guys on Loran-C antennae.

- (2) Ultraviolet Deterioration. Ultraviolet rays from the sun can cause discoloration, deterioration and/or breakdown of the fiberglass matrix. All Coast Guard rods are either protected with a whitish titanium dioxide coating, or fabricated with a slightly less effective urethane filler for protection against ultra-violet rays. Some rods have lost their coating through weathering, exposing the rod and causing some discoloration. However, tensile tests have shown that the coating loss does not affect strength. Uncoated rods having a translucent greenish color sometimes exhibit a "bamboo" appearance with time, but this is due to the way in which the rod is wrapped while it is cured in the factory and strength is not affected. Coating repairs have been attempted on existing rods, such as sanding and painting with acrylic paint or covering the surface with a special dielectric tape. The cost effectiveness of this maintenance must be examined on a case by case basis.
- (3) Weathering. Following coating loss, the outer fibers of rods tend to fray or break, and give a fuzzy appearance. Salt, dirt, and dust can be more readily trapped and less easily washed off by rain, and tracking may be accelerated (see next paragraph). Rods in this condition should be carefully inspected for signs of tracking.
- (4) Tracking. Tracking in the case of fiberglass rods can be described as progressive carbonization of a material by the electrochemical reaction created by an electrical discharge. Tiny droplets containing some contaminant may form a terminal for a partial discharge (leakage of current) from the clevis tip. This leakage current produces a localized heating of the rod surface, which in time oxidizes the polymer leaving a thin carbon track. This track then becomes the jumping-off point for another arc to another droplet farther down the rod. In fiberglass rods, it is the coating or resin matrix that tracks - not the glass. Tracking creates a conductive path that eventually grows such that the original insulative properties are lost; at this point the insulator that is tracking literally burns up. The presence of moisture and contaminants accelerates the rate of deterioration. Corona facilitates electrical breakdown by effectively increasing the electrical surface of the conductor. A gradual loss of cross-section accompanies severe tracking, and ultimately structural failure occurs.
- (5) Insulator Twisting. On 625-ft Loran-C towers, the rod pairs of structural guy fiberglass insulator assemblies may become twisted (Figure 6-10). In the past, this twist has been successfully removed using the following procedure:



Figure 6-10 Twisted pair of fiberglass train insulators.

- (a) Rotate the guy at the anchor end in a direction contrary to the twist of the rods.
 - (b) After several turns, the effort to rotate will become noticeably greater; at this point, stop the rotation even though the twist may not be removed.
 - (c) After the passage of at least several months, inspect the rod pairs to see if they have twisted farther. If the twist is not removed to a satisfactory degree, repeat a. and b. above, and check again after several more months. Lab tests have shown that more than 360° of twist at the rated breaking tension is required before failure occurs, and that significantly greater twist can be tolerated at lower loads.
- (6) Surface Cracking. Transverse cracking has occurred in 1/2-inch fiberglass guys after only a few years of service. In some cases, these cracks extended into the glass filaments, causing structural failure. All fiberglass rods should be closely examined whenever circumstances permit, for evidence of this kind of cracking.
- c. Inspection and Maintenance of Fiberglass Rods. All fiberglass rods should be checked at regular intervals for signs of wear, tracking, discoloration, cracking, etc. The end fittings should be checked for any sign of distress, and the clevis checked for

corrosion or deformation. The least accessible, yet electrically most highly stressed, fiberglass rods are at the ends of the TLEs of 625 ft and 700 ft Loran-C towers. Binocular or telescope inspection should be regularly accomplished, and selected rods should be closely examined every few years using the procedures of Appendix E. Both structural and radial insulator rods may be replaced with no off-air time, as detailed in Appendix E.

M. Gradient Cones and Arcing Rings. The development of devices for the protection of fiberglass insulator assemblies from electrical effects has mostly been the result of trial and error. There are a number of cones, rings and other devices now installed on Loran-C towers; some are adequate, some unnecessary, and some of questionable value. This section describes current requirements. Modification of existing towers is not required unless it is convenient to add onto the scope of related work or there is a severe electrical problem at a particular tower.

1. Gradient Cones. A gradient cone, similar to that shown in Figure 6-11, is required where fiberglass insulator rods are connected (via a yoke plate) to an energized cable such as a top-loading element or SLT antenna panel. These cones are effective in reducing the voltage gradient at the clevis tip, thus reducing the potential for tracking (see ►K.2.a(4) above). Servicing CEUs should contact the Tall Tower Coordination Center for design parameters and details.

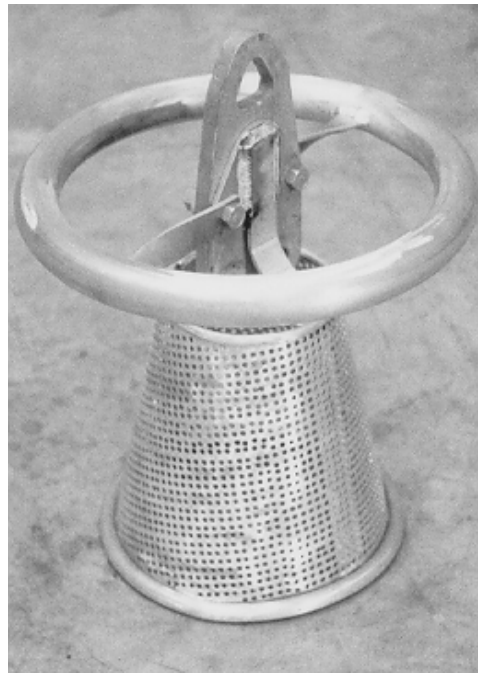

Figure 6-11 One type of gradient cone used on energized towers.

2. Arcing Rings. An arcing ring, similar to existing "corona rings" as shown in Figure 6-12, is required where fiberglass insulator rods are connected (via a yoke plate) to an unenergized cable such as a structural guy or an SLT backstay. This ring is designed to attract any lightning or flashover surge that would otherwise strike the clevis tip. It should be a smoothed tubular ring of 1 inch outside

diameter, and the plane of the ring should extend at least 6 inches beyond the clevis tip in the direction of the insulator. The overall ring diameter should be such that should one rod fail the remaining rod will not contact the ring under static conditions.



Figure 6-12 One type of corona ring, in place on a structural guy.

3. Tower Connections. Where a fiberglass insulator assembly is connected (via a yoke plate) to any tower leg, no device is required at the tower end. Old "corona rings" at such locations may be removed if they are deteriorating, but may be kept in service if their condition is satisfactory.
 4. Materials. New or replacement cones and rings should be fabricated from galvanized or stainless steel.
- N. Tower Anchors. The tower anchors are normally constructed of reinforced 3,000psi concrete and are designed to support the vertical and horizontal forces imposed by the tower. Tower guys are connected to steel anchor arms (eye-bolts or channels) which in turn are securely embedded in the concrete anchors (Figure 6-5). Although current standards require all anchor steel below ground level to be encased in concrete, there are many existing installations where a major portion of the guy anchor arms are in direct contact with the soil. The two major elements of guy anchors are discussed below.
 1. Concrete. Concrete is considered to be a permanent structural material and when properly designed, mixed, and placed, should last indefinitely. To fully serve its purpose in foundations, anchors, and encasements, concrete must be of high quality and of sufficient cover over the embedded anchor and reinforcing steel to protect them from corrosion. Only high quality concrete can withstand continued exposure to water, freezing and thawing, and other adverse conditions. Considering the locations of various towers and the conditions under which they were erected, it should not be taken for

granted that all foundation, anchor and encasement concrete is high quality and fulfilling its intended purpose.

2. Anchor Steel. In many instances, the galvanized steel anchor arms (eyebolts and channels) are in direct contact with the soil and consequently are subject to corrosion. It should be noted that in the presence of water or moisture, where a combination of steel and concrete occurs (as in the case of all tower anchors), the unencased steel is anodic (sacrificial) to the steel encased in the concrete, and corrosion of the exposed steel can be expected. The corrosion process is further discussed in Ch.4 ►D.3. While the anchor steel is galvanized and has a built-in factor of safety, which permits some loss of cross-section, it is unwise to expect indefinite trouble-free service without inspection and maintenance attention. At least one radial anchor arm has failed at the point where it entered the anchor, and several cases of severe loss of cross-section or pitting have been found at the interface with the concrete anchor. New or replacement anchor steel should have a factor of safety of at least 5.
3. Inspection of Components. Inspection of the guy anchors presents a difficult problem in that the major elements of these structures are concealed. The means for accomplishing subsurface inspections are discussed in Chapter 4 ►C.6. Inspections of exposed and exposable galvanized anchor steel should be guided by the discussion in Ch.5 ►C.5. The timing or frequency of inspections, determined by the servicing CEU, should be based on the soil conditions, corrosive environment and history involved. The inspection should note and record the surface condition of the anchor arms. If the anchor arms are found to be in good condition, one of the protective coatings, described in later in this section should be applied to those anchor arms. In the event a substantial loss of cross-section or other structural deficiency is found the servicing CEU should be consulted as to proper corrective action before proceeding. Structural and encasement concrete should be checked for cracks and spalls, mechanical damage, and erosion. When subsurface concrete is exposed, the surfaces should be tapped and probed with a chisel or screwdriver to check for soundness and integrity. Cracking, spalling, surface indications of rusting of embedded steel, and/or expansion of salt and ice crystals all indicate presence of low quality porous concrete.
4. General Above Ground Inspections. The anchors should be checked periodically for settlement or lateral movement. Slight vertical and horizontal movements cannot be detected with the unaided eye, but movements of serious proportions can be visually detected. Such inspections should look for evidence of mounding or folding of the soil at the front face of the exposed or encased anchor arms with an accompanying crevice on the back side. Where there is reason to suspect anchor movement, periodic instrument checks should be conducted. Where anchors are located on fill material of relatively soft or unstable soil, bench or control markers should be installed close by on firm ground as a means for checking or monitoring movement. Constant reduction in guy tensions may also be indicative of anchor movement.

5. Maintenance. Whenever normally hidden foundation and anchor elements are exposed for inspection, preparations should be made to accomplish anticipated maintenance at the same time. The most common form of maintenance will consist of coating the anchor arms that are in direct contact with the soil, and patching cracks and spalled areas in the surface and subsurface concrete elements. When the anchor arms are initially exposed, the protective treatment, depending on the condition found, should be one of the methods described below. It should be emphasized that the purpose of such coatings is to isolate the anchor arms from the soil environment and the coatings must be applied properly and be of sufficient thickness. If the coatings do not provide a completely positive seal, corrosion can take place under the coatings without being detected.
 - a. Bituminous Coating Protection. There are various types of petroleum based protective coatings. Although proven effective, these coatings are no longer recommended, in favor of epoxy coatings.
 - b. Special Protective Coating. There are several types of special protective coating systems that may be used where corrosion control becomes a serious and expensive problem. These coatings are described in the Coatings and Color Manual, COMDTINST M10360.3(series). Since the surfaces to be protected by the coatings must be highly cleaned in order to provide a proper base for the coatings, their use will be limited to extremely high maintenance areas. Epoxy coatings when properly applied provide adequate protection for anchor arms.
 - c. Concrete Encasement. In many soil environments, concrete encasement is a preferred and economical way to provide protection for anchor arms. When this type of protection is applied, the concrete cover over the steel should not be less than 3 inches and must be designed to provide an impermeable barrier for the anchor steel. Before encasement, the anchor steel should be painted with an asphalt-based paint or similar material. All new installations, when feasible, should incorporate concrete encasement for guy anchor arms, reinforced and tied into the anchor to reduce cracking and spalling from vibration. Concrete sleeves that are not tied to the parent anchor will not provide adequate protection under load, and eventual separation from the anchor and exposure of the anchor arm at the anchor interface will most likely occur.
6. Drainage and Landscaping. In order to preserve the original design conditions, the soil surrounding anchors must be maintained in a stable and well-compacted condition with the ground surfaces sloped away from the anchor arms to provide adequate drainage. Ponding of water should never be allowed, since the structural stability of the anchor can be diminished and settlement or lateral movement may occur. Also, ponding of water around exposed anchor steel invites corrosion. Landscaping or the installation of surface or subsurface drains should be provided where ponding is a problem. Vegetation should not be permitted to grow in the vicinity of the anchors.

0. Tower Guy Accessories.

1. Guy Tensioning Devices. Most guyed towers have been furnished with hydraulic tensioning devices or dynamometers for use during tower erection and subsequent guy tension measurements. These are important and delicate instruments that must be maintained in the best possible condition at all times, if they are to provide the necessary accuracy. In the event these devices are dropped, mishandled, damaged, or otherwise believed to be inaccurate, they should be immediately repaired and recalibrated or replaced. They should also be calibrated prior to any retensioning efforts. Shunt dynamometers are furnished with calibration curves or tables that should always be kept with the instrument. See Chapter 8 for further discussion on guy tensioning.

2. Guy Pulling Devices. Various devices, generally referred to as cable or wire grips, are available and used to pull guys into the anchors, hold the guys in place during disconnection and/or to slacken guys away from their anchor connections. The grips normally consist of two opposing jaws that tighten around the guy cable in a vice-like manner as the grip is pulled along the line or plane of the cable. Some cable grips utilize wedges or are specially designed to prevent slippage if the pulling action on the grip is eased. Some have permanent or insertable soft metal (bronze, copper, lead) jaw plates for use with aluminum and copper coated cable to prevent nicking or similar damage to the cable surface. Double concave jaws should be used with fiberglass guys to minimize surface damage. These grips are normally used with "come-along" hand or puller hoists. Only properly sized and shaped grips should be used, and grips should be kept in good working condition to prevent slippage and loss of a guy. Preformed Big-Grip dead-ends can be safely used as pulling grips if the following precautions and procedures are observed:
 - a. Use of the correct Big-Grip dead-end size and material.
 - b. Use a properly sized heavy-duty thimble at all times.
 - c. Carefully check the physical condition of the dead-end before use. If there are corroded or broken strands, discard grip. Check loop to be sure that there are no sharp bends.
 - d. Be sure that the upper end of the dead-end is tight against the guy cable (not loose or unraveled).
 - e. Never apply a pulling force at an angle from the line of stress; i.e., come-alongs or winch leads must be connected to or fair-led through a point on or immediately adjacent to the guy anchor arm. The dead-end should be installed as far up the guy as possible to provide an optimum line of force.
 - f. Use the Big-Grip dead-end for minor tension or length adjustments only. Use regular jaw grips for slacking the guy into the tower, pulling the guy back to its approximate connecting position at the turnbuckle or for similar erection or maintenance work.
 - g. Be sure the Big-Grip dead-end is holding fast and not slipping before disconnecting the primary guy coupling to the anchor.

- h. Ensure that the guy connection points are not allowed to rotate during operations. The rotation of guys fastened to a Big-Grip can cause the Big-Grip to open slightly. The opening of the Big-Grip can lead to the release of the guy cable.
 - i. Once a Big-Grip dead-end has been installed and used as a pulling grip, it shall not be removed and reinstalled for use again. However, it may be permanently installed and used many times. Once removed it must be discarded.
3. Guy and Guy Anchor Related Spare Parts. Whether through initial outfitting or subsequent procurement, a variety of structural and electrical spare parts are usually available for each tower or antenna system. Typical parts are hardware or expendable items such as turnbuckles, Big-Grips, light bulbs, nuts, bolts, mercury switches, and johnny-ball insulators.
- a. Identification. All tower spare parts must be carefully identified and maintained in like-new condition. Servicing CEUs should ensure that station personnel can accurately identify each spare part, by attaching tags, providing detailed descriptions, or whatever method is most appropriate. Any item that is in questionable condition should be discarded.
 - b. Inventory. An accurate inventory of all tower spares should be available at the station and in the office of the major field commander. This inventory should be updated periodically by responsible station personnel. Local experience should dictate detailed spare parts requirements, based on station isolation, long lead-time items, and probability of failures.
 - c. Storage. Antenna system spare parts should be stored in a specially designated location at every station, and access to this area should be strictly limited. Items that may be adversely affected by exposure to weather (Big-Grips, lighting system components, etc.) should be stored indoors.
 - d. Procurement. It is recommended that all major tower parts procurement be coordinated by the servicing CEU, except that the station may be made responsible for procuring minor electrical system items such as lamps and mercury switches.

CHAPTER 7. TOWER PAINTING

A. General. Tower painting is accomplished for three reasons:

- To provide obstruction marking, if required by the FAA;
- To extend the life of galvanizing;
- To help prevent corrosion.

The use of galvanized steel or aluminum for all Coast Guard towers and similar coatings or materials for guys, hardware, and other components in some cases precludes the need to paint to preserve the surface. The reason for painting with the orange and white color bands is to meet the visibility requirements of the FAA.

1. FAA Marking Requirement. Refer to FAA Advisory Circular 70/7460-1(series) for complete marking requirements. The marking requirements set forth in this chapter provide a summary of the information in the Advisory Circular as it relates to Coast Guard Towers. The Federal Aviation Administration recommends that all towers presenting a hazard to air commerce be marked with alternating bands of aviation surface orange and white unless they are marked with high-intensity lighting systems. In general, all towers greater than 200 feet in overall height above ground level are to be marked and/or lighted regardless of geographical location. Towers with an overall height of less than 200 feet may require obstruction marking depending on their location in relation to airways, landing areas, and land forms. Under certain conditions, a tower may not require obstruction marking if the tower is shielded by a higher structure that is properly lighted and marked. An aeronautical study by the FAA is required in this case.
2. Responsibility for Tower Marking. It is the responsibility of the Civil Engineering Unit to determine whether the marking of new towers is required, and to ensure that all towers are marked as required by the FAA. The conditions under which towers must be marked and when FAA Form 7460-1 should be submitted is discussed in FAA, Advisory Circular AC 70/7460-1(series). If an existing tower to be replaced is less than 200 feet in height and was previously painted, consideration should be given to painting the new tower to maintain visual familiarity.
3. Maintaining Tower Visibility. The current FAA Advisory Circular on tower marking, AC 70/7460-1(series), states that repainting is required "when the color changes noticeably or its effectiveness is impaired by scaling, oxidation, chipping, or layers of industrial contamination". Any decision to repaint should take into account other factors, such as the condition of the paint, the need to repaint for protective purposes, and the anticipated life of the tower. Where doubt exists as to the adequacy of daytime tower visibility, the FAA should be consulted. The current scheme for color band characteristics calls for each band to be approximately 1/7 the tower height, for towers not exceeding 700ft in height. Consult Advisory Circular 70/7460-1(series) for towers exceeding 700ft in height.

4. Painting New Galvanized Towers. If a new galvanized steel tower does not have to be painted for daymarking, it may be painted if it is located in a harsh environment in an effort to extend the life of the galvanizing. This decision is the responsibility of the CEU, and it must be based on an economic and environmental analysis. All local factors and the projected lifecycle costs must be included in this analysis. The life of the galvanizing, the life of the paint system, and the life of the structure as defined by operational need are sometimes difficult to estimate; a sensitivity analysis covering such variables should be performed as a part of the economic analysis.

B. Maintenance of Tower Painting. Complete tower repainting is an expensive and time-consuming undertaking. Many times a good touch-up painting will postpone the need to completely repaint the tower for two to five years. (As a rule of thumb, complete repainting in the field can be expected to have about 1/2 the life of the factory applied paint.) In any case, for corrosive environments, it is much less expensive to maintain a coating system, preventing it from failing, than it is to maintain a coating system once it has failed, the galvanizing has been lost, and the steel has as begun to corrode. The man-hours involved in surface preparation and coating application are the key to the savings realized by maintaining a good paint system. A discretionary policy of touch-up cleaning and painting should always precede complete repainting. The Coatings and Color Manual, COMDTINST M10360.3(series) should be consulted for information on painting techniques, paint materials, and safety precautions. Other sources for similar information, recommendations, and sample specifications are:

The Society for Protective Coatings (SSPC). SSPC Special Reports and standards for coating of steel, available from the SSPC.
<http://www.sspc.org>.

American Galvanizers Association. "Suggested Specification for Preparing Hot-Dip Galvanized Surfaces for Painting (1998)". Available through 1-800-HOT-SPEC or <http://www.galvanizeit.org>.

1. Tower Repainting. Towers should not be repainted to improve appearance if they have adequate visibility (see ►A.3 above) and there is no reason to paint for surface protection. Complete repainting should be governed by the overall condition of the existing paint coating and not by premature localized failures. Normally the best time to repaint is when the old paint evidences general erosion or deadening of the coating. It is always better to repaint with the same type of material originally used unless there are clear indications that different materials will be compatible with the old system. Some of the newer coatings contain solvents that may act as efficient paint removers on old conventional paints. It is often necessary to completely remove the old paint from all surfaces to avoid problems of incompatible paints and to ensure proper adhesion of the new paint. When severe corrosion of the galvanizing layer of the tower is attributable to the sand blast effect described in Chapter 5, it is important to use a paint based on a penetrating type vehicle so as to get into the small pores created. The same paint should also be heavily pigmented with an abrasion resistant pigment to counteract such future erosion.

2. Touch-up Painting. Touch-up painting should not be done merely to improve appearance. Towers with over 70% paint loss have been considered to be "adequately marked" because the remaining white and orange color patches had the required effect on the human eye at distances which are of concern to pilots. The discussion in ►B.1 above applies whenever touch-up painting is required to improve visibility. Touch-up painting is most frequently accomplished when corrosion control is necessary. When this involves corrosion of the base metal in corrosive environments, a choice must be made between either complete rust removal, reconditioning, and maintenance of a protective coating system, or "worst" rust removal, efforts to slow the corrosive process, and a plan to eventually replace the corroded components when enough cross-section has been lost. Only a comprehensive economic analysis can show which choice should be made. A careful appraisal of each situation will help to determine the most economical maintenance program. It is important to inspect structures from the top down, because the worst corrosion occurs on the uppermost sides of the horizontal members and cannot be readily seen from the ground. In making these inspections, the rusted areas or those showing the common rust color, should be carefully examined and wire brushed. If the red color can be removed in this way, and if good zinc (for galvanized towers) still remains after the cleaning, the problems are not severe. For such instances, all surfaces showing any red stain should be thoroughly wire brushed and a single coat of paint will usually suffice and give an average life nearly equal to that of the paint job done before failure. On towers with spots that have none of the original galvanizing remaining, it is necessary to scrape and chip these areas, then wire brush them well, and then touch up these spots with a primer coat of rust-inhibitive paint. When this is completed, the tower is ready for the finish coat. In relatively non-corrosive environments, the decision to slow the corrosion process has proven sufficient because the corrosion process, even unaddressed, does not pose a serious problem. In severely corrosive environments, the decision is not so straightforward. It is important to note that painting before the galvanizing layer fails simplifies the painting process and significantly extends the life of the paints that are applied.

3. Lead Paint. Refer to your servicing CEU environmental branch for the most current requirements for environmental and worker protection from lead paint hazards. The requirement to paint towers can be waived if high-intensity lighting systems are used. However, an existing paint system that may contain lead paint cannot be neglected regardless of FAA marking requirements.

C. Standard Tower Painting Systems. Most Coast Guard towers which require painting are made of galvanized steel. The following paint systems should give good service when applied to new galvanized steel towers prior to erection:

1. Normal Environment. (limited or no salt spray or industrial pollutants, normal humidity levels):

a. One coat Epoxy-Polyamide Primer (MIL-P-24441).

b. Two coats Silicone Alkyd (MIL-E-24635) or Acrylic Enamel (TT-E-2784).

2. Moderate or Severe Corrosive Environment. (high humidity, heavy salt spray and/or pollutants):
 - a. One coat Zinc Rich Epoxy Primer (MIL-P-24648).
 - b. One coat Epoxy-Polyamide Primer (MIL-P-24441).
 - c. Two coats Silicone Alkyd (MIL-E-24635) or Acrylic Enamel (TT-E-2784).

- D. Alternative Painting Systems. In those cases where the standard paint system has failed to provide reasonable service, a more durable system may be selected. Where experience on the suitability of other painting systems is lacking, field experimentation is encouraged in accordance with ►H below. Should field experimentation be undertaken, COMDT(G-SEC) and the Tall Tower Coordination Center should be periodically advised of the coating system performance. It must be emphasized that when choosing a coating system, the ability to recoat can be just as important as the bonding, weathering and intercoatability.

- E. Corrosion Protection of Unpainted Towers. Sometime during the life of unpainted towers, it may become necessary to provide some sort of protection against corrosion.
 1. Galvanized Steel Towers. The zinc coating of structural steel members may be destroyed by corrosive action that is sometimes accelerated because of flaws in the coating itself. Such corrosion can be identified as discussed in Chapter 5 ►C.5. Loss of the sacrificial zinc coating will result in rusting of the underlying steel. Efforts to restore the zinc through the application of zinc dust paints have not always been successful in the field, because this type of coating requires the complete removal of all rust (a white-metal surface preparation), constant agitation (to ensure that the zinc dust remains in suspension) and proper mil thickness application. Failure to meet these basic requirements has resulted in substandard performance. To be effective, the manufacturer's instructions must be carefully followed when using these products. A better solution for field touch-up of galvanizing layers is the use of cold galvanizing compounds. These compounds are readily available and have proven themselves in a variety of tower locations. Cold galvanizing compounds (both spray and brush-on) are an excellent rust inhibitor and are easily applied. The surface requires mechanical or wire brush cleaning before application.

 2. Aluminum Towers. The aluminum alloys used for tower structural members have a high resistance to atmospheric corrosion. However, serious corrosion in the form of surface pitting can occur after prolonged exposure to severe environments. Deeply pitted areas should be reconditioned by cleaning and wire brushing, then Priming with a Zinc Chromate rust-inhibitor primer (TT-P-645), then coating with a ready mixed Aluminum Paint conforming to TT-P-38. The American Society of Civil Engineers (ASCE) "Suggested Specifications for Structures of Aluminum Alloys" should be consulted for recommendations on coating or painting aluminum surfaces, especially

where dissimilar metals are fastened or attached to the aluminum structure.

3. Galvanized and Aluminum Coated Steel Cable and Associated Hardware. In addition to the zinc dust paints noted in ►E.1 above, there are commercially available special coating compounds that will inhibit further deterioration of the metal. Petroleum-based products have been used successfully on turnbuckles and exposed portions of anchor arms. Keeler and Long #4405 RIFC Anodic Self-Priming Stainless Steel paint has been applied to galvanized structural guys on a 1350-foot tower. Development of such compounds is relatively rapid, and extensive testing prior to field use may not be possible. CEUs who use new products of this type are requested to forward to the Tall Tower Coordination Center brochures, cost data and the results of periodic evaluations of performance. Compounds containing oil or grease bases should not be used over preformed Big-Grips. There is a possibility that lubrication of the interface between the grip and the cable may result, causing the grip to slip.

- F. Ladders and Safety Rails. See Chapter 5 Section F for information on coating ladders and safety rails.
- G. Application. Brushes are normally used for tower painting, and will normally ensure proper paint thickness application. Hand mitts or other applicators may be used providing that there are no restrictions by the paint or coating manufacturer and that the specified thickness can be met.
- H. Records. Records of completed paint jobs are a good means of determining the best paint job for a particular surface and environment. The surface preparation, coating system (including application methods) and site conditions must be accurately documented to properly evaluate the performance of a coating system. Inadequate surface preparation, improper coverage or mil thickness, or overcoating a prime coat with something other than that specified by the manufacturer are examples of circumstances that make performance evaluations invalid or at least suspect. The weather conditions, the surface preparation method used, the condition of the surface after cleaning and just prior to coating application, the coating system used, the method of application, the costs, the long term performance and the suspected cause of failure will allow a meaningful evaluation of completed jobs and will help determine methods of improvement for future work. Acceptance or rejection of any system should be made on a case by case basis and backed with a sound economic analysis.

CHAPTER 8. TOWER ERECTION, ALIGNMENT, TWIST, AND GUY TENSIONS

- A. General. In order to perform properly under wind and/or ice loadings, the alignment and twist of a tower under no-load conditions must be maintained within the limitations imposed by the tower designer. If the tower is guyed, the initial tensions must likewise be maintained within design limitations. When a tower is properly fabricated, assembled and erected, maintaining these characteristics within design tolerances can be a relatively easy task. However if any one or more of these have not been correctly accomplished, maintaining proper tower alignment and twist will become an almost immediate post-erection problem which will become increasingly difficult to correct. Towers will adjust to their environment and some loosening of structural fasteners and stretching of cables on guyed towers, for example, can be expected after erection. The influence of these conditions on tower behavior can be such that alignment and twist limitations may be exceeded as the wind and/or ice load approach their design maximum. Since these adjustments are likely to occur after exposure to annual weather cycles, the requirement for yearly tower inspections is recommended (see Ch. 3 ►C.1). These inspections should include checks of alignment, twist, and guy tensions. To provide a better understanding of the importance of tower alignment, twist, and guy tensions, a brief discussion of tower design and behavior follows.
- B. General Tower Design Characteristics. Towers are designed to withstand the loading conditions (wind and ice) which are expected to exist in the geographic location where they will be placed in service. The legs are designed to carry the compressive load. The horizontal and diagonal members are designed to transmit wind and gravity loads throughout the tower framework without inducing flexure in the leg members. Horizontal members serve essentially as spacers between tower legs. The diagonals, usually designed to carry only tension, provide resistance to shear and control leg alignment.
1. Guyed Towers. Guyed towers are usually triangular in cross-section and have a constant face width. On some towers the base section may be tapered inward to a pin connection. Structural guys are symmetrically anchored around the tower with initial tensions as required to provide proper stiffness to the tower. Guys are tightened to an initial tension of about 10% of their breaking strength. Under full design load the tensions will increase to about 40% of the cable's breaking strength. These towers are analyzed as continuous beams supported on elastic foundations. The base is usually treated as a pinned connection and any section above the topmost level of guys is considered as a cantilever. Guyed towers are designed to deflect laterally under wind loading to the extent permitted by the catenary and elastic elongation of the supporting guys. Under certain wind and ice loads the tower can bend simultaneously about the two major axes and also twist. In addition, on top loaded monopole antennae, such as those used for Loran-C, lift and drag wind forces acting on the top loading cables can cause the top of the tower to deflect into the wind.
 2. Self-Supported Towers. Self-supported towers may be triangular or square in cross-section and may either have a constant face width or taper with height. They are designed as a cantilever with a rigid

base connection. Under design wind and/or ice loadings, the tower legs are subject to both compression and tension forces. Deflection of self-supported towers increases from zero at the base to a maximum at the top. Twisting is usually minimal, the degree being primarily a function of the eccentricity of antennae and other appurtenances mounted on the tower. Most self-supported structures have high built-in torsional rigidity to meet the directional and stability requirements of installed equipment. Therefore, there should be no problem with tower alignment and obviously no concern with guy tensions.

- C. Analysis of Existing Towers. Special analysis or evaluations of abnormal tower alignment, twist, or guy tension conditions have been made by the Coast Guard. This research has included the study of reverse deflection, apparently excessive deflection under limited wind conditions, twisting of towers beyond the designer's or manufacturer's recommended limits, and crossing of guy pairs. The extent of such analyses has varied, but their results have been partially translated into inspection and maintenance policies which are now incorporated in this manual. Civil Engineering Units are encouraged to evaluate abnormal tower conditions on a local level as much as possible; however, when local analysis is inadequate or inconclusive, an evaluation by a Professional Structural Engineer should be considered.
- D. Cause of Misalignment and Twist. Misalignment and twist can occur in a tower for a number of reasons. Temporary misalignment and twist can result from wind and ice load as discussed in section B above. Permanent misalignment and twist can be caused by improper guy tensions. Twist can be caused by improper assembly and erection techniques, such as a systematic rotation of bolt tightening which produces a built-in twist in the tower framework.
- E. Alignment, Twist and Guy Tension Limitations. To obtain true tower alignment without twist an ideal set of conditions would have to exist during the alignment process. There would have to be no structural failures, loose fasteners or built-in twist, no wind or ice effect, with all guys at each level having equal lengths, identical catenaries, and equal temperatures. Consequently, from a practical point of view, true tower alignment is an impossible condition to achieve. In view of this, tolerances are given in Erection Manuals for tower alignment, twist and guy tension. If an erection manual is not available, see ►G.1.e below concerning alignment tolerances; tensions and tolerances will be provided by the Tall Tower Coordination Center, and existing twist should be monitored for change.
 - 1. Erection or Built-in Twist. Towers can be erected to the manufacturer's twist tolerances if proper erection procedures are used and qualified, experienced personnel are assigned to the job. This assumes, of course, that the tower has been properly designed and fabricated. In this respect, experience has shown that the preferred method for minimizing and controlling erection twist is to assemble tower sections on the ground using a jig to ensure straightness, and to tighten all bolts before raising the section in place by gin pole or crane. Opinions vary as to whether the bolts should be fully tightened on the ground or after the section is positioned in the air. This is usually left to the option of the erector. However, bolts should be tightened in a random pattern

rather than following a systematic pattern of proceeding around the tower in the same direction on each section. This could result in a serious twist. Twist may be most easily monitored during erection through the use of the "Leg Sighting" Method described in ►G.2.a below. Erection twist that may occur can usually be reduced to within specified tolerances by loosening and retightening bolts. There have been cases where the erection twist exceeded recommended limits and the circumstances forced acceptance of the tower with excessive twist. This problem has so far been limited to a few 625-ft. face-guyed towers, where as much as 4 to 4 1/2 degrees of twist has existed since erection without problems, compared to the rather restrictive 1/2 degree limit specified by the manufacturer. Towers can also be twisted with respect to the guy anchors because of a misalignment of the tower legs when the first sections were set on the base insulator. Although the tower has a pin-type connection at the base insulator, once the first sections are resting in place, rotation of the tower to bring the legs in line with the guy lane directions requires a considerable effort. As additional sections are set in place, correction of this type of misalignment or twist becomes impractical. The impact of this misalignment is not easily determined, but an alert inspector can eliminate it altogether during the tower erection process. Studies made at one station revealed that less than 1 degree of twist could be removed by severely unbalancing tensions in adjacent guys. Based on these studies and various other factors, the following policies have been adopted relative to erection twist.

2. Every attempt should be made during erection to maintain tower twist within manufacturer's tolerances by using proper erection procedures and qualified personnel. Erectors should be made fully responsible for erecting the tower within tolerances, and structures with excessive twist should not be accepted.
3. Where erection twist cannot be controlled or reduced to within tolerance, and acceptance must be made for operational or other purposes, the twist should be reduced to the minimum possible without unbalancing guy tensions or modifying the structure.
4. Measurements of tower twist subsequent to erection should be compared to the amount of twist measured at the time of erection and not to the specified tolerances. For this reason, the most accurate available method (see ►G.2.a below) should be used to measure the tower's twist immediately following erection, and the values recorded in the central file for the tower.

F. Conditions for Alignment, Twist, and Tension Measurements. As indicated above, an ideal set of conditions for guy tensioning, alignment, and twist measurements and adjustments will never occur. A practical set of conditions are:

1. Ground level wind speed of not more than 10 knots.
2. No ice accumulation on tower or guys.

3. Temperature distribution throughout the guys as equal as possible; this can generally be achieved during periods of cloud cover or in the early morning.

Measurements of any kind will seldom agree if taken at two different times. In order to obtain the best possible data, an effort should be made to perform each measurement or adjustment under which the previous measurements or adjustments were made.

- G. Determination of Alignment and Twist. Several methods of measuring alignment and twist of a tower are outlined below. All methods are acceptable for various conditions, but each has certain inherent inaccuracies that should be recognized and considered when results are interpreted.

1. Methods for Determining Alignment.

- a. Visual Check. This is a very quick, unsophisticated means of obtaining a rough check of tower alignment following storm conditions or when instruments are not available. The observer positions himself outside of the antenna field, in line with the tower and a guy of the highest level. For Loran-C towers, the top-loading radial guys should be used for this method. He must also be directly upwind or directly downwind from the guy. The guy that hangs vertically is then compared to the tower or a tower leg, thus giving a rough indication of the tower alignment. When the wind shifts, or if it is calm, a similar sighting is made from behind another guy that is as close as possible to 90 degrees away from the first guy. Significant deflections may be estimated using the tower face width dimension as a guide.
- b. Transit Check Method. This is an accurate method of obtaining an indication of tower alignment, but several inherent errors noted below cause final results that contain a measure of uncertainty. In this method, readings taken by transit or theodolite from two positions 90 degrees apart are plotted, resulting in a "bird's eye view" of the tower. The steps below apply to a triangular shaped tower, but the principles are readily adapted to a square-section tower, see Figure 8-1.
 - (1) Transit Readings. Set up a transit (position "T1") in the antenna field far enough from the tower to permit convenient sighting of the tower top, yet near enough to permit a reasonably accurate estimate of the deflection based on a leg diameter as a guide (i.e. typically at the TLE for a LORAN-C tower). Ensure that all tower legs are clearly visible, and that all legs will be visible from a second transit position 90 degrees away from position T1. Firmly embed the transit legs, and level the transit.
 - (2) Align the vertical cross hair with the edge of any tower leg at the base of the tower, then lock the scope to prevent horizontal movement. Elevate the line-of-sight to each guy attachment point and each midpoint between guy levels; record the direction (left or right) and amount (using the leg diameter as a guide) of deflection at each point. The leg

diameter of taller towers varies at different elevations and at pull-off points, and must be taken into consideration.

- (3) Repeat step b. above for all tower legs.
- (4) Plunge and invert the scope, check transit level, and repeat b. and c. above. This will eliminate collimation errors. Average the two sets of readings for each leg.
- (5) Move to transit position "T2", located a similar distance away from the tower, but 90 degrees away from T1. Obtain averages of deflection readings on all tower legs as described in b. through d. above.
- (6) To facilitate subsequent transit setups, it is suggested that permanent markers or concrete transit pads be established at optimum T1 and T2 locations.
- (7) Plotting results. On standard graph paper, draw an equilateral triangle representing the tower in plan view. Ensure that this triangle is correctly oriented so that T1 and T2 lines-of-sight may be represented by the horizontal and vertical graph paper lines. See Figure 8-1.
- (8) The averaged readings for each leg at each level from T1 and T2 are used to plot triangles representing the various levels. The triangle plotted in step (7) above is taken to represent the tower at the base, and thus the location of any cross-section through a perfectly plumb tower. Plot the true locations of each leg at each level by first drawing a horizontal line representing the line-of-sight from T1, and then a vertical line representing the line-of-sight from T2.
- (9) Use an exaggerated scale to plot deflection readings. That is, do not use the scale inferred by the original triangle drawn in step (7) above. This will allow a clearer view of the many triangles to be plotted, and will permit a more accurate indication of the final deflection figures.
- (10) As each triangle (representing the true position of a given level of the tower) is plotted, find its center using perpendicular bisectors of any two sides. Indicate this by a dot, and use a label such as "4" for the 4th guy level. Using the exaggerated scale, the distance from any such dot to the center of the "base" triangle is the measured deflection of the tower at that elevation.
- (11) Due to the effect of various errors, the plots will not normally be equilateral triangles. Twist will be indicated by the triangular plots, but will be exaggerated because of the exaggerated scale; superior methods of measuring twist are discussed in ►G.2 of this chapter. By plotting all three legs, the effects of twist and imperfect triangles is minimized when obtaining deflection readings.

(12) Steps 7-11 above can be completed using an AutoCad drawing program. If this is done, then the use of an exaggerated scale is not necessary.

(13) Errors. Human errors in operating the instrument and estimating deflections, instrument errors other than collimation, aberrations of the line of-sight, and movement of the tower while readings are taken contribute to the inaccuracy of the transit check method.

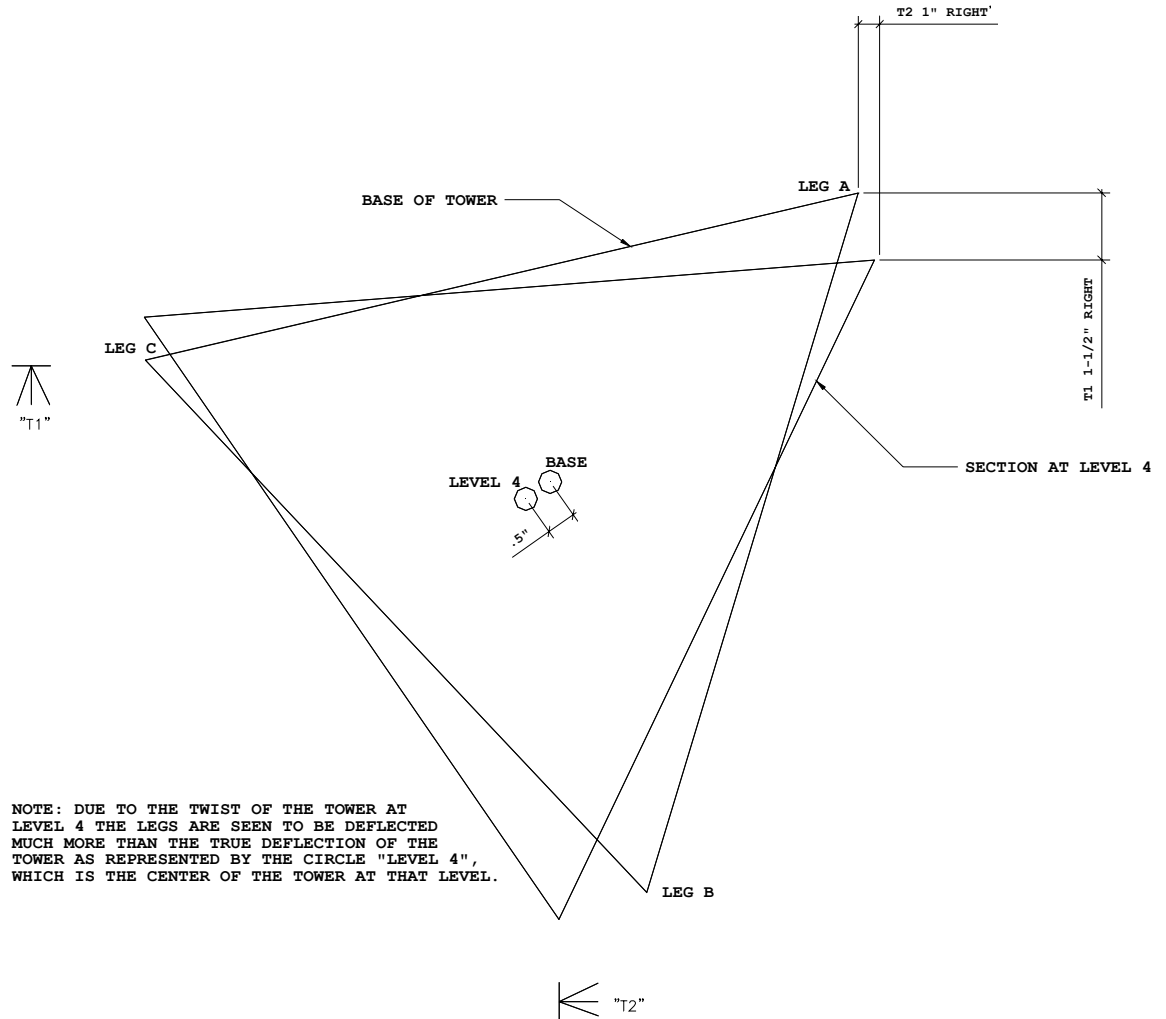

Figure 8-1

c. One-Leg Method. This method uses the same basic principles of the Transit Check method, but it is much easier to plot results and the final alignment plot can be made on the spot in the field. However, three transit setups are required instead of two.

(1) Locate the transit in the antenna field (see Ch. 8 G.1.b(1) above) so that two tower legs appear approximately in line. This is position "T1". Align the transit reticle on the edge of the third leg (not one of the two legs in line) and take deflection readings at points up to the tower top just as in

the Transit Check method. Plunge and invert the scope, take duplicate readings, and average the results.

- (2) The key to the plotting lies in having available special (but easily constructed) plotting paper, as shown in Figure 8-2a. These lines are drawn at 60 degrees to each other, and the center of the plot (small circle) represents the center of a perfectly plumb tower. (See Pg. B-20.)

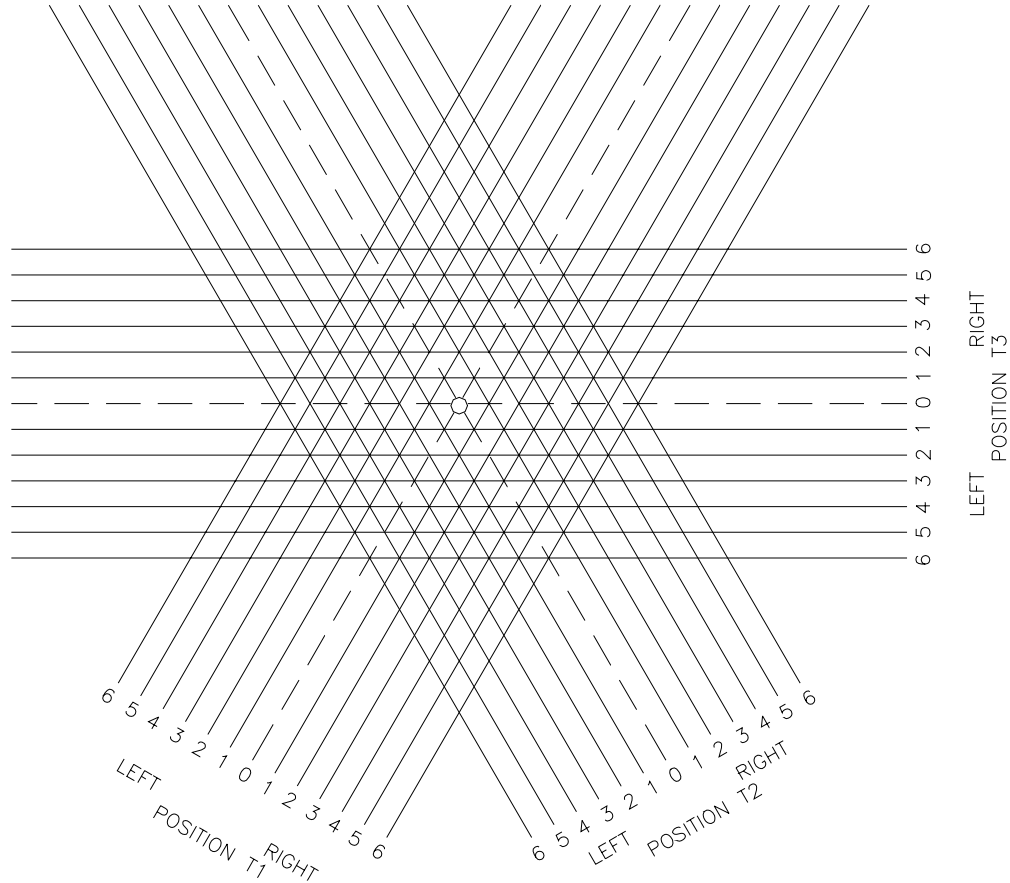

Figure 8-2a

- (3) Referring to the family of parallel lines noted as "T1", plot a line representing the deflection reading for the particular elevation. In Figure 8-2b, a deflection of 1 1/4 inches left has been plotted.
- (4) Now move to transit position "T2", 60 degrees further around the antenna field, where two legs again are approximately in line. Take deflection readings on the third leg as before, and plot results using the "T2" family of parallel lines. In Figure 8-2b, a deflection of 1 inch left is plotted.

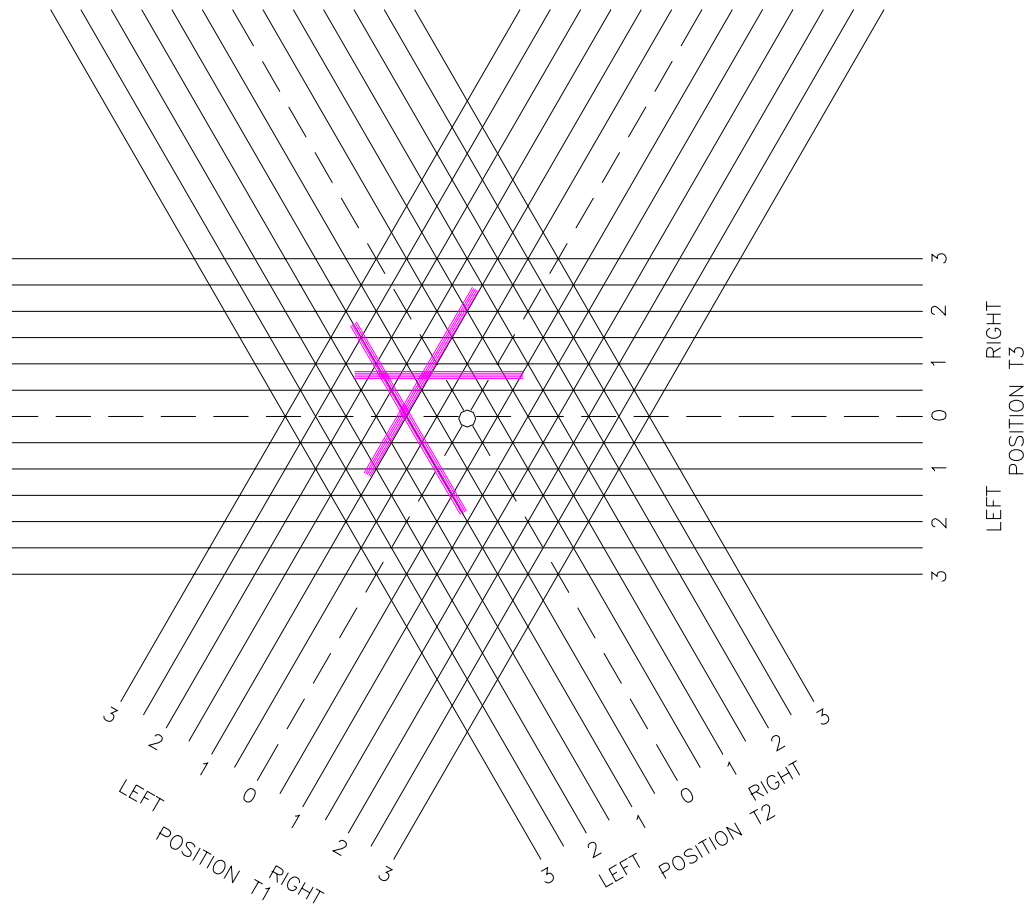

Figure 8-2b

- (5) Move to transit position "T3", another 60 degrees further, and repeat the procedures of recording deflection of the third leg. In Figure 8-2b, a deflection of 3/4 inches right is plotted.
- (6) The measurements are now complete and a triangle is formed on the plotting paper. The center of this triangle represents the plot of the tower center at the particular elevation, and the scaled distance and direction from the small circle is the probable true deflection. Under ideal conditions, the triangle should be a point; however, the readings become less accurate with distance, and the size of the triangle can be expected to increase accordingly. As readings are taken up the tower, efforts should be made to keep the triangles as small as possible. If a very large triangle is plotted, a reading is automatically suspect and can be taken again on the spot.

(7) The effects of tower twist are automatically eliminated when using this method, but on the other hand no indication of twist is obtained.

d. TIA/EIA Method. This method uses a procedure of calculations developed in the TIA/EIA Structural Standards for Steel Antenna Towers and Antenna Supporting Structures. This method gives accurate results from the data of a 3-transit set up. It will give both the alignment and twist from the data. The procedure does however require calculations from a computer spreadsheet. A copy of the spreadsheet along with the procedures can be acquired from the Tall Tower Coordination Center or the procedures and calculations can be taken from the TIA/EIA manual. This method is an accurate method with results that can be obtained relatively quickly compared to other methods.

e. Allowable Deflections. The maximum allowable deflections permitted shall be as specified by the tower manufacturer or designer. When such deflections are not specified, the following shall apply:

(1) The maximum allowable deflection at the top of the tower ("Dtop") is equal to the lesser of:

$$\frac{H_{top}}{720}$$

OR

$$\frac{W}{20}$$

(Htop is the height of the tower and W is the tower face width.)

(2) The maximum allowable deflection at any other elevation "H" is equal to:

$$\frac{D_{top} \times H}{H_{top}}$$

(3) The maximum allowable deflection between consecutive guy levels is equal to:

$$\frac{D_{top} \times L}{H_{top}}$$

(Htop is the tower height, and L is the distance between guy levels.)

2. Methods for Determining Twist. Five methods are discussed below, with those most highly recommended given first. Accurate twist measurements should be made during every tower inspection and checked on the spot against previous measurements. Any significant change in tower twist will indicate a problem (see ► D above), and an investigation should be undertaken.

a. Leg Sighting. This is the most simple and most accurate of all methods, but climbing the tower is necessary. This method is highly recommended for use during erection of a tower.

(1) Highly visible targets must be placed at the outer portion of the antenna field, usually adjacent to a top-loading radial

anchor where the distance to the tower is known. These targets are located along the circumference of an imaginary circle whose center is the tower; they are placed every 1/2 degree, or every 1/10 of a degree for greater accuracy. For example, targets placed at the radial anchors of a 625-ft. Loran-C tower, 850 feet from the tower, would be spaced at 1 1/2 foot intervals in order to indicate every 1/10 degree. The 0 degree target should be exactly in line with a tower face at the base of the tower.

- (2) An observer on the tower at any elevation may then sight along the outer edges of two tower legs and directly note the twist using the targets; interpolate between targets as necessary. It is important to use large, brightly painted targets, to locate the targets away from the sun relative to the observer, and to clearly distinguish the 0 and whole-degree targets from the others. See Figure 8-3.
- (3) On towers energized with high-powered transmitters, the high voltage gradients outside the legs may cause shocking which could preclude the use of this method.

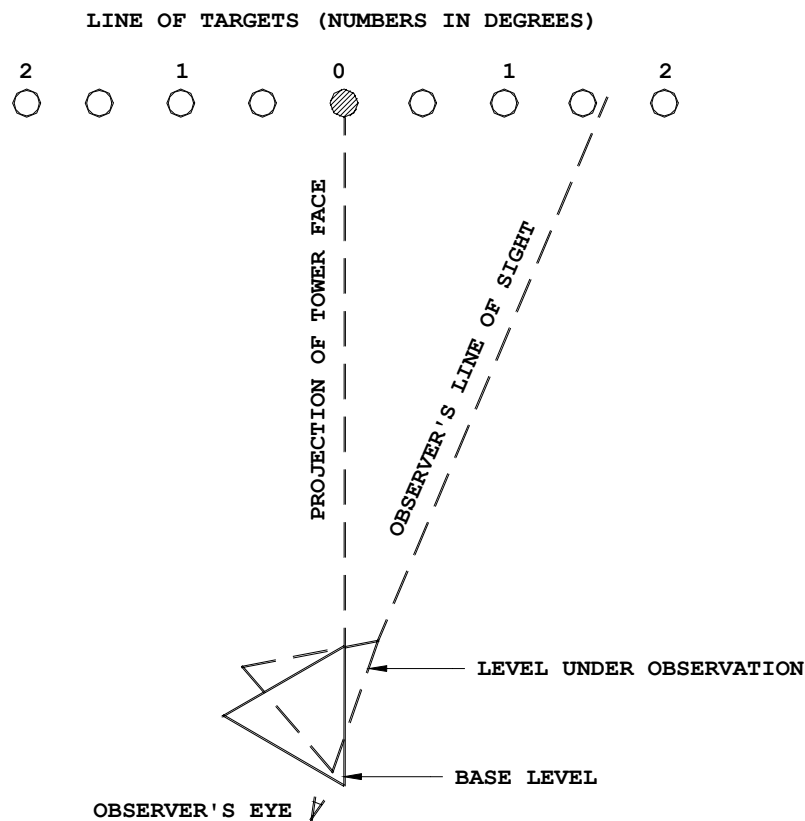

Figure 8-3 Leg Sighting Method for Twist Measurement.

- b. T-Square Method. This method uses the same basic principle as leg sighting, but relies on a device for sighting on targets rather than on the alignment of two legs. It may be used on all towers which may be climbed while energized (see Ch.2 Part II.B), but it is necessary to carry the device up the tower.
- (1) Highly visible targets such as described in ►G.2.a above must be placed at the outer portion of the antenna field, but are located such that the 0 degree target is exactly in line with the perpendicular to a selected tower face.
 - (2) A T-square shaped device is fabricated of rigid lightweight materials. The top of the "T" should be designed to rest securely upon any horizontal tower member. The stem of the "T" should be about two feet long, and fitted with a nail (or similar projection) at each end. This device is then carried by the observer on the tower. At each elevation where twist is to be measured, the device is rested near the midpoint of the horizontal member and the targets are sighted using the two nails on the stem of the "T".
 - (3) This method comes highly recommended because of its accuracy, but it has the obvious disadvantage of encumbering the observer with the T-square device. Inaccuracies may be introduced because of bent or distorted horizontal tower members, and it is good practice to use an average reading obtained from measurements using 2 or 3 vertically adjacent horizontals.
- c. Visual Check Method. If the tower is not to be climbed, or other reasons preclude the use of the above two methods, the visual check method should be used. This method is sometimes referred to as "Walking the Radials".
- (1) An observer on the ground is equipped with a transit, theodolite, or high-powered telescope of some kind. The observer-positions himself a known distance from the tower, in line with the projection of a tower face, usually at or near one of the top-loading radial anchors. The observer then marks the position, point ("A"), which is directly in line with the outer edges of the two overlapping tower legs at the tower base. See Figure 8-4.
 - (2) Sighting up to the first guy level, the observer moves left or right until the tower legs at this level appear in line. This point ("B") is then marked by a convenient object on the ground. The distance between this object and the point "A" can be related to the twist of the tower between the base and the first guy level by simple trigonometry equation, (see Figure 8-4).
 - (3) For example, assume the observer is near a radial anchor of a 625-ft. Loran-C tower, 850 feet from the tower. The observer has moved to the right 4 feet in order to line up to the two legs at the first guy level. The twist angle in radians is therefore, $4/850$; multiply by 57.3 to obtain degrees. The twist is 0.27 degrees counterclockwise.

- (4) The procedure in (2) above is repeated for each guy level, and the twist at each level computed according to the distance of the respective marker (point "A").
- (5) Accuracy of this method is primarily dependent on the ability of the observer to clearly see the alignment of the legs at the distances involved. For best results, follow these guidelines:
 - (a) On sunny days, sight along the tower face that is toward the sun, with the sun behind the observer. Align the outer edges of the legs.
 - (b) On cloudy days, use the gap between legs to determine alignment of the legs; that is, align the inner edge of the near leg with the outer edge of the far leg, or vice versa. The observer should be positioned where legs are best silhouetted against a bright sky.
 - (c) Use a high powered optic on a stable platform; a good theodolite is cumbersome but otherwise satisfactory. If possible, measure from the same spot from year to year.
 - (d) Measurement from a radial anchor not only gives an accurate distance from the tower, but allows absolute measurement of the twist of the base section by using the anchor as a positive point of reference.

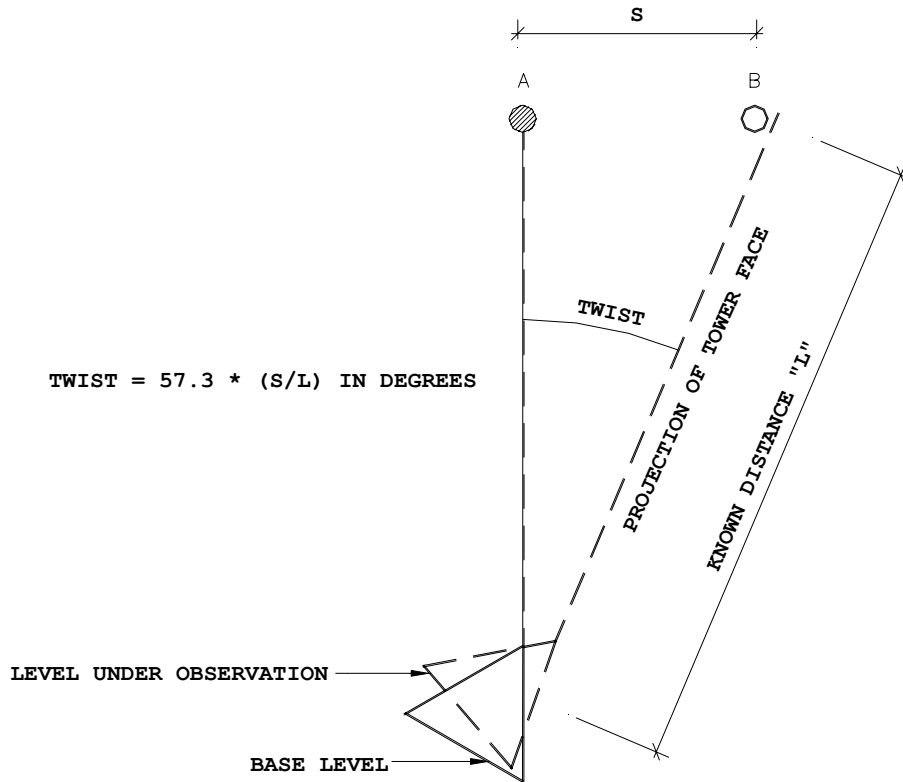

Figure 8-4 Visual Check Method for Twist Measurement.

- d. Boresighting. This method uses a cross-shaped device, fabricated of rigid lightweight materials, which is taken up the tower by the observer. One cross member is designed to rest against two tower legs, while the other is free to pivot and is fitted with two nails for sighting on a radial anchor or any other appropriate target. Graduations marked on either arm (depending on design) are used for readings of twist in degrees. Not only is it necessary to carry the device up the tower, but the accuracy of the final measurement cannot compare with measurements obtained using the chord of the angle, as in the three foregoing methods.
 - e. Transit Check Method. Twist may be obtained from the plot of cross sections at various elevations as described in ► G.1.b above. However, an exaggerated scale should not be used to plot deflections; the deflections must be plotted in true proportion to the scale of the triangle representing the tower cross-section. All of the errors noted in ► G.1.b(12) above contribute to the inaccuracy of this method. This, plus its basic inferiority to the foregoing twist determination methods, leads to the recommendation that it be used as a rough check only.
- H. Guy Tensions. The initial tensions should be maintained during no wind, no ice conditions to ensure that the guys and the tower are properly loaded if maximum design forces are experienced. Guy tensions and tower

plumbness are the primary indicators of the stability of the structure. It is therefore desirable to measure tensions in appropriate guys at each major tower inspection using a method or device which has good accuracy and, equally important, good repeatability. Prior to guy retensioning, the need to retension should be verified by the use of a recently calibrated guy tension measuring device. The calibration test should duplicate field usage of the equipment as much as possible. For example, for a 625-ft. Loran-C tower, the guy calipers should be calibrated with the dynamometers installed; calibration of the dynamometers alone is not considered adequate. The use of recently calibrated guy tension measuring devices during the actual retensioning effort cannot be overemphasized.

1. Master Lane. For the massive 1350-ft Loran-C towers the manufacturers specify initial tensions in one lane of guys only, because of the great physical effort required to obtain a tension measurement. Guys in a "lane" share the same, or nearly the same, vertical plane. If tensions within this "master lane" are within specified tolerances, and at the same time the tower is within its tolerance limits for verticality, then the tensions in the guys of the remaining two lanes must be acceptable. This method should be reserved for 1350-ft towers. This master lane should be as specified by the manufacturer or the one whose anchors are at elevations which are closest to the elevation of the tower base, since tensions are usually specified for an idealized flat site.
2. Methods for Measuring Tension. Coast Guard tower guys range in size from about 1/4 inch to over 2 1/2 inches in diameter; initial tensions vary from a few hundred pounds to more than 50 thousand pounds. There are therefore several entirely different approaches to the single task of tension measurement, depending on the circumstances. The methods described below are listed in general order of preference, but not all methods may be used on all towers.
 - a. Calipers. A guy tension caliper is a scissors-type device that is quick and simple to use, and is ideal for guys whose initial tensions do not exceed 3000lbs. See Figures 8-5 and 8-6. By modifying the design, but retaining the same basic principle, caliper-like devices have been developed for guys whose tensions are 12,000lbs (see Figure 8-7). The arms of one side of the caliper are designed to fit inside the thimble of the guy end and to straddle the eye of the connecting turnbuckle. The other arms are connected to a dynamometer, and have a crank-operated screw mechanism for tensioning. By turning the crank, the turnbuckle eye and thimble are separated, and the guy force is transferred through the caliper arms to the dynamometer. This gives a direct reading of guy tension. The caliper is preferred for use on all towers up to about 700ft in height, but it may be unnecessarily sophisticated for towers shorter than 200 feet. It is simple, quick, and accurate, and is endorsed without qualification by all who have used it. Great attention to the turnbuckle/ thimble detail is necessary for caliper design.

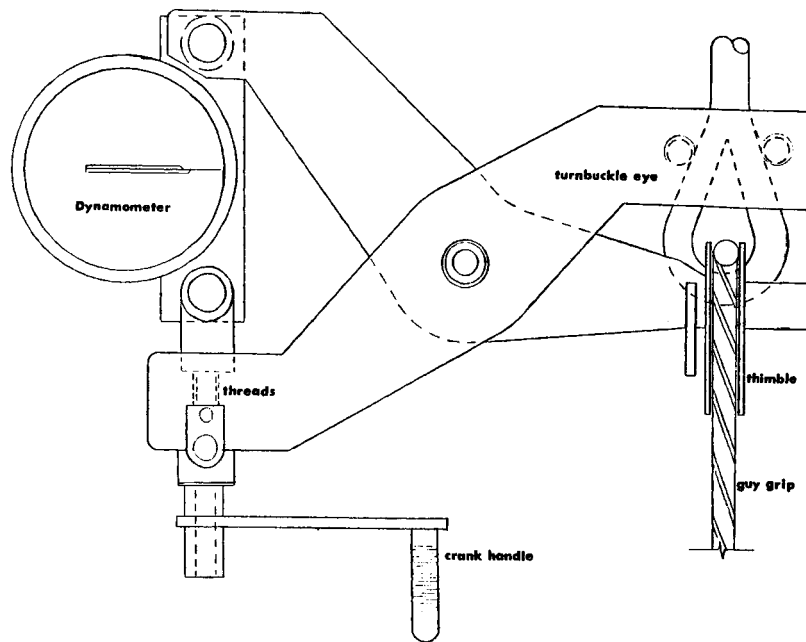

Figure 8-5 Guy tension caliper.

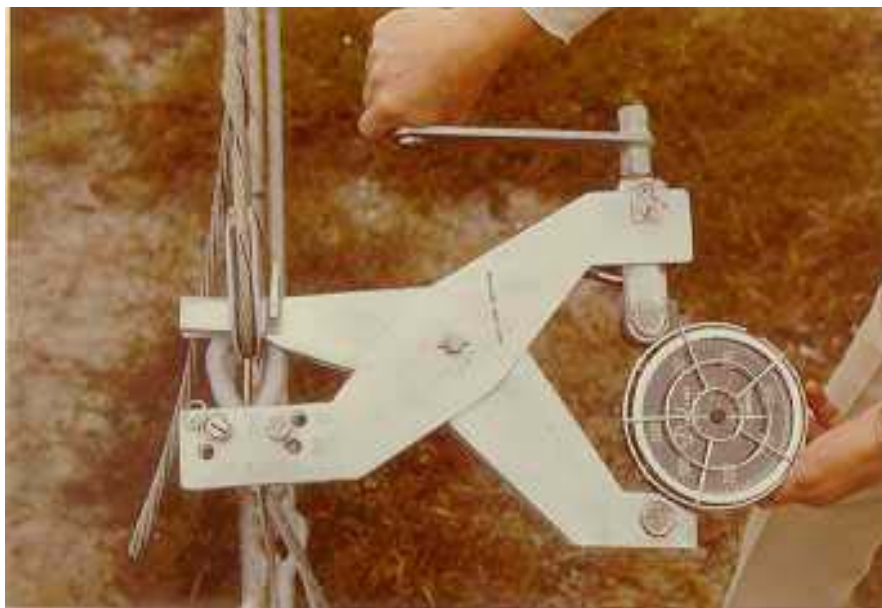

Figure 8-6 Guy tension calipers for tensions up to 3000lbs.

- b. Tensiometers. A tensiometer (Figure 8-8) is basically a spring balance that is placed between the guy and the anchor to measure tension directly. The tensiometer has a distinct disadvantage in that it must be attached in parallel to the guy using a "come-along", and it is difficult to determine when the full load has been assumed by the instrument. This method is most commonly

used during erection of guyed towers less than 1000 feet in height, or during major guy length adjustments; the tensiometer can be easily inserted in series with the come-along and the tension of the guy measured before connection to the anchor is accomplished.

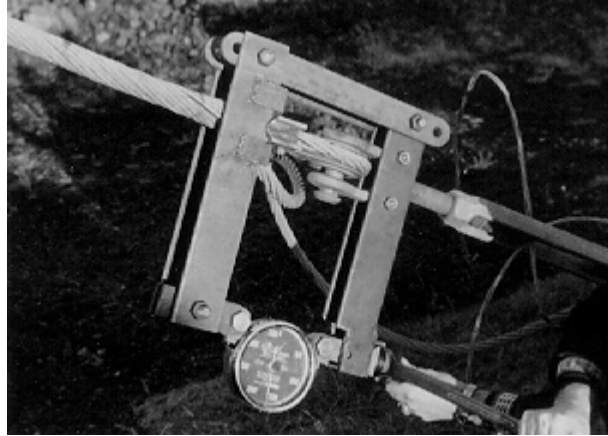

Figure 8-7 Guy tension calipers for high tension guys.

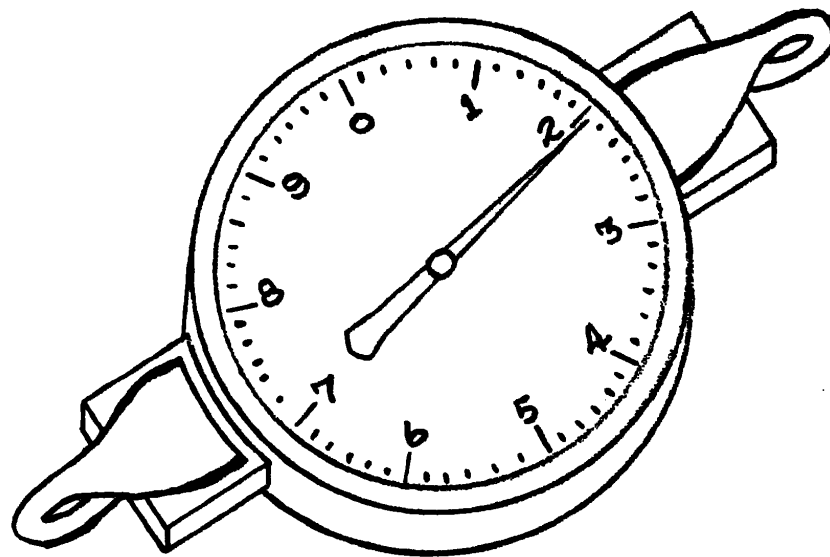

Figure 8-8 Tensiometer.

- c. Slope Measuring Device (SMD). Catenary equations show that for a given guy construction, site and tower geometry, and guy tension, the angle of the guy at the anchor can be computed. Therefore, since guy construction and site geometries do not change, the slope of a particular guy at its anchor can be used to indicate the tension in the guy. An instrument for measuring this slope is the SMD shown in Figure 8-9. The SMD is recommended only for guys which are too large to accommodate calipers. The repeatability of the SMD is very good, within 6% under worst

conditions; however, its accuracy is dependent on prior calibration of each particular guy through the use of a very accurate device such as the "TMD" (7-7-2-4). Accuracy based on calculations using catenary equations is questionable. The SMD shown in Figure 8-9 is configured such that a measurement of the cosine of the angle of the guy is obtained along the vernier scale, which reads to thousandths of an inch. Through a calibration process, curves plotting tension versus SMD readings are generated, and kept with the instrument; a separate curve is required for each individual guy. The main advantages of the SMD are simplicity, rapidity, and ease of handling. Once a historical collection of SMD readings is accumulated, it is easy to quickly check tensions on the largest towers within reasonable limits.

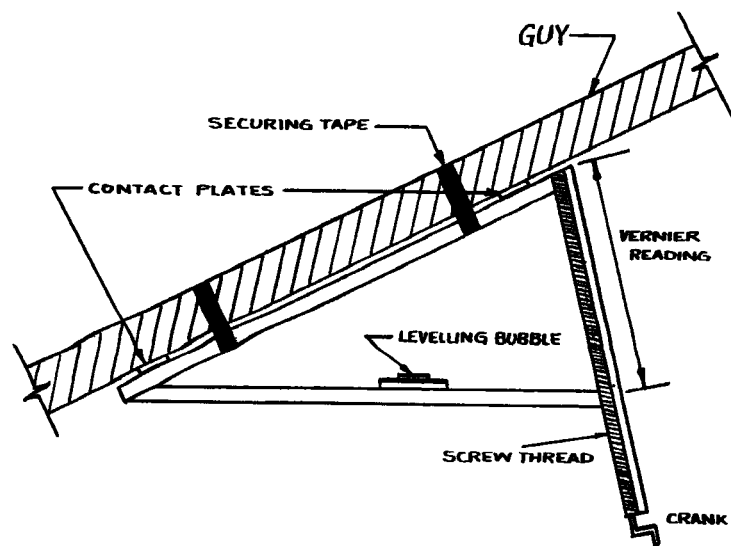

Figure 8-9 Slope measuring device.

- d. Tension Measuring Device (TMD). The TMD employs two very accurate tensiometers and a complex apparatus for mounting onto the bridge sockets and hairpins at the anchors of large towers with high-tension guys. Although 3 - 4 men are required to use the device, its accuracy and repeatability for large guys is very good. Variations of the TMD have been developed for other very large towers.
- e. Hydraulic Tensioning Device. This type of device is used for measuring and adjusting tensions in the guys of the larger towers. The device consists of a hairpin harness and jacking bars with two hydraulic rams connected by a flexible hose to one pumping unit. A gage is attached to the pumping unit, calibrated directly in pounds or showing a pressure that may be converted to pounds. Hydraulic rams and hairpins are required to unseat the bridge socket from the hairpin nuts, but this equipment is cumbersome, requires several people, is time consuming, and provides limited accuracy in tension measurement. An alternate to the jacking harness method is the hydraulic ram method. Note

that, to use this method, there must be sufficient room at the end of the closed bridge socket U-Bolt to back a nut off and insert the steel plates and hydraulic rams. The gages and rams must be calibrated together at frequent intervals for either method.

- f. Shunt Dynamometers. A shunt dynamometer, one type of which is shown in Figure 8-10, is a simplified device for tension measurement. It may be used on cables up to about one inch in diameter. It is a deflection-type indicator that is clamped onto a guy, and measures guy deflection as it applies a force to the cable. It is important to realize that each dynamometer must be calibrated for the particular size and type of cable on which it will be used. The manufacturer's instructions should be strictly followed. To obtain optimum results, three readings should be taken on each guy at slightly different positions along the guy. The final measurement should be an average of the three readings. Shunt dynamometers are best for small, flexible guy cables. If the shunt dynamometer is calibrated and used correctly, it can yield accurate results, although its accuracy can be affected by cold temperatures.

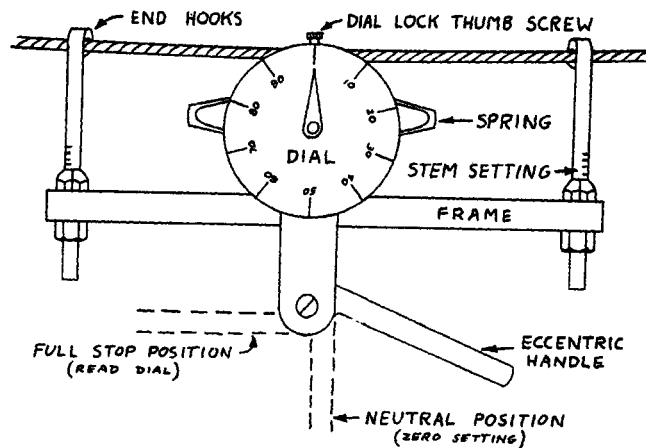

Figure 8-10 Shunt dynamometer.

- g. Visual Sag Method. This method makes use of the principles of catenary equations, as does the slope-measuring device, to relate the observed geometry of a guy to its theoretical tension. This method is most appropriate for guy cables whose weight per lineal foot is nearly uniform. It is the fairly good repeatability of this method which makes it useful, not its accuracy; its accuracy is further limited when there are insulators in the guy acting as point loads. The visual sag method is of particular use when the visual sag tension can be correlated with the tension of the particular guy as measured at the same approximate time by one of the tensioning devices described previously. If a record of visual sag tension is maintained when several tensioning device measurements are taken, it is possible to develop a plot of "visual sag method tension" versus "tensioning device tension".

Subsequent visual sag method readings may then be converted using the resultant curve. This results in a relatively simple means whereby station personnel can periodically check the tension in the guys. If commonly used within their area, it is recommended that Civil Engineering Units prepare curves for the use of station personnel that plot T vs. I for each guy in the master lane. The curves may first be based on theoretical values, then further modified as field data is accumulated through the use of tensioning devices. Refer to Figure 8-11.

- (1) Attach a sighting device to the underside of the guy at the anchor end so that the line-of-sight is tangent to the axis of the guy at that point.
- (2) Determine the "intercept" distance (I) between the line of sight and the guy pull off by counting girts and multiplying by the girt spacing.
- (3) Calculate tension at the anchor (T) using the equation given in Figure 8-11.

$$T = \frac{WL}{2I} (L^2 + I^2 + H^2 - 2IH)^{\frac{1}{2}}$$

where $W = \frac{1}{L} \times$ (total weight of guy & insulators)

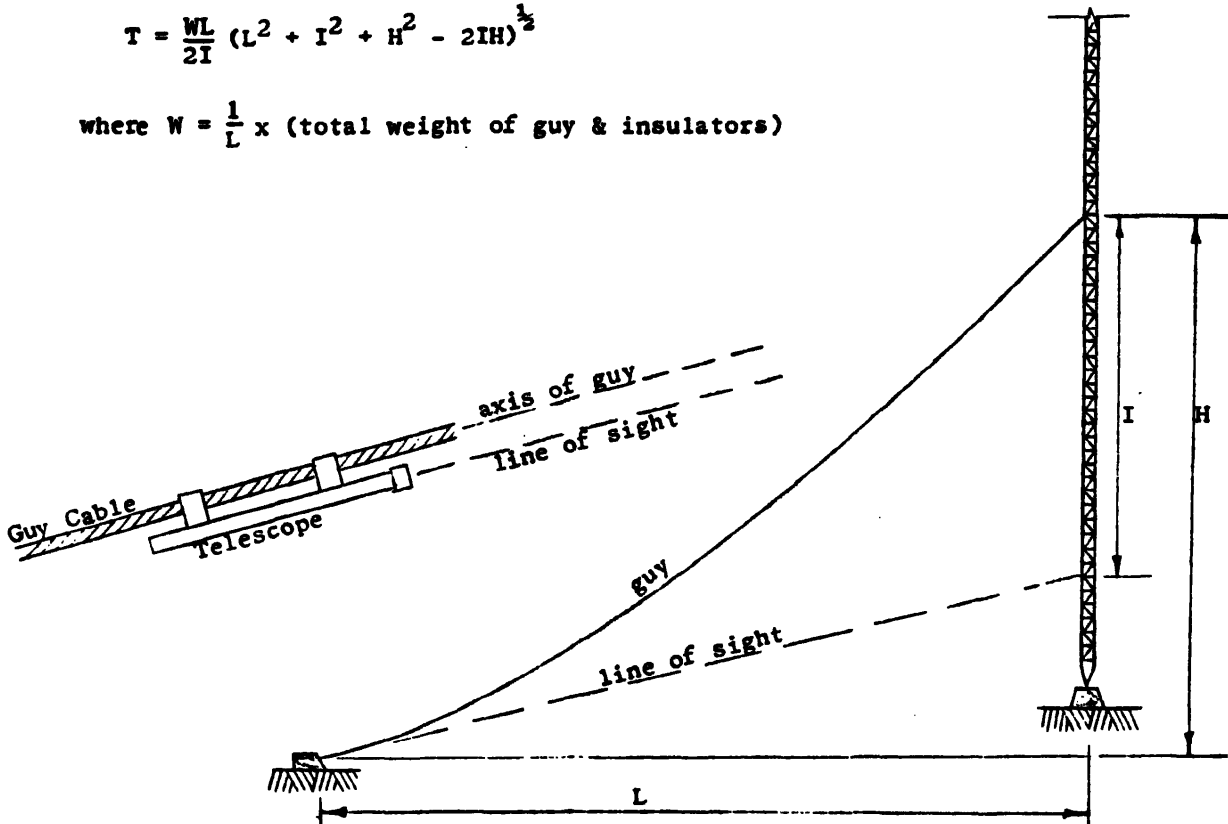

Figure 8-11 Visual Sag Method.

- I. Correction of Alignment and Guy Tension. Correction of tower alignment or guy tensions should only be attempted by experienced and qualified

personnel and only when an overall improvement in alignment and/or tensions is required and can be expected. There are many ways to correct alignment and tensions on guyed structures, and no single method or approach can be specified for every structure. **Correction of alignment will involve an adjustment to guy tensions, but these changes should not be such that the guy tensions become out of tolerance.** Based on various experiences with Coast Guard towers, corrections should be accomplished with the following in mind:

1. On face-guyed towers it is more important to maintain a balanced condition in the guys (guys in each pair with equal tensions/catenaries) than to sacrifice this balance in an attempt to counteract twist. Field tests have shown that guy pair tensions must be unbalanced by more than 50% to remove less than one degree of twist. This imbalance would be more detrimental to the integrity of the tower structure during design winds and ice than the slight amount of twist that may exist in the tower. (See ►E.1 above for discussion of twist.)
 2. Most deviations in tower plumbness on multi-level guyed structures can be corrected to within specified alignment tolerances by careful adjustment of guy tensions. Adjustments should be made incrementally, since large changes in tension at a given guy level can cause changes in the alignment and tensions at adjacent guy levels. There are situations when both alignment and tension tolerances cannot be met concurrently and a compromise of one or both must be made. As a rule, once tensions for each guy lane have been established, the tension tolerances should take precedence over alignment tolerances. A good deal of judgement is required when determining if this is the situation and the extent of the compromise. The accuracy of the equipment being used and the weather conditions at the time must be considered. Experience has shown that, generally, only small sacrifices have to be made to the alignment tolerances in order to bring the tensions within acceptable limits.
 3. Most adjustments of guy tensions can be made within the range of the attaching turnbuckles or U-bolts. If a physical length change of a guy is required, the turnbuckles should be left with a 40-60% take-up to facilitate minor adjustments in the future. New Big-Grip dead-ends should always be used when adjusting guy lengths subsequent to initial tower erection. (See Ch.6►H.3.b)
 4. Complete and detailed records of all adjustments should be maintained. A record of weather conditions, tension/alignment/twist values before, during and after adjustments will greatly assist in understanding the response of the structure and in simplifying subsequent corrective actions.
- J. Frequency and Scope of Alignment and Tension Checks. Tower alignment, twist, and guy tension checks should be made on a regular basis at a frequency to be determined by major field commanders. These checks should be accomplished by qualified Coast Guard or contractor personnel and should include observation of the guys for excessive vibrations and any unusual tower behavior or condition. In addition to these scheduled inspections, alignment, twist, guy tension checks and general tower condition observations shall be conducted after each heavy storm, during

and after heavy icing of the tower or guys, and after earthquakes, as discussed in Ch.3 ►B.4. If only visual inspection methods are employed after severe conditions, and the tower appears out of alignment or is twisted, or guy tensions appear slack, an instrument-assisted inspection should be made as soon as possible; no one should be permitted to mount the tower.

CHAPTER 9. TOWER LIGHTING AND LIGHTNING PROTECTION

- A. General. Coast Guard towers may have obstruction lighting systems. These systems must conform to Federal Aviation Administration standards for the protection of air navigation. The FAA Advisory Circular 70/7460-1(series) uses 200ft as a threshold for determining whether a tower or structure is an obstruction and therefore must be marked (painted or lighted). The FAA may also recommend marking or lighting a structure that does not exceed 200ft because of its particular location. Refer to the FAA standards in the Advisory Circular AC 70/7460-1(series). In recent years, concerns have been raised by some groups regarding the use of red obstruction lights versus medium and high intensity strobe lighting systems, in particular as it relates to migratory birds striking taller towers. No requirement is in place to replace one system with another, as research and debate on this issue continues. The number of installations of medium and high intensity lighting systems is increasing, particularly on Nationwide DGPS towers, as well as some LORAN towers, most notably the SLT type antenna. Some original high intensity systems suffered frequent maintenance problems. Newer systems currently being installed have not suffered the same magnitude of problems encountered by earlier systems. Advisory Circular AC 70/7460-1(series) provides detailed information on the requirements and specifications of high intensity lighting systems. It is the responsibility of the CEU to ensure that the tower lighting system conforms to the appropriate standards. Any tower construction and or modifications originating from the respective unit commander, CEU, FD&CC, or other engineering organization shall be responsible for coordinating with the tower's field commander and local FAA to ensure that current standards and regulations are met. Typically, for any alteration to a tower greater than 200 feet or within certain distances from airports/runways, FAA Form 7460-1 ("Notice of Proposed Construction or Alteration") is required at least 30 days prior to the work. If applicable, coordinate with the local FAA office as to where the form should be sent. The unit or company generating the work is responsible to ensure that the FAA is notified of pending work and that all required FAA forms are submitted per the FAA requirements.
- B. FAA Notification Requirements for Tower Lighting Failures. Coast Guard field units responsible for towers shall immediately contact the FAA upon learning of a tower lighting failure. All Coast Guard stations responsible for towers and their associated lighting systems and equipment shall have the phone number of their local FAA office that should be notified. Details are available in FAA Advisory Circular AC 70/7460-1(series).
- C. Tower Lighting System Components. The erection and maintenance manual for each tower should contain specific information on the lighting system and its components. The components listed in this section are for towers that will be lit using red obstruction lights, not medium or high intensity systems.
1. Flashing Beacons. Typically, 300-mm coded beacons are installed at the top of all towers over 200 feet in height and at one or more intermediate levels for towers in excess of 350 feet. The beacon typically consists of two clear Fresnel lenses, red filter, gaskets,

and two 620-watt or two 700-watt pre-focus lamps. The top and bottom sections of the beacon are hinged at the mid-point for ease of relamping. Both pre-focus lamps burn and flash in synchronization. Some fixtures have a vented dome at the top to allow air to circulate and heat to escape so to reduce the internal light fixture temperature. A drain port is typically located in the base to prevent accumulation of moisture. See Figure 9-1.

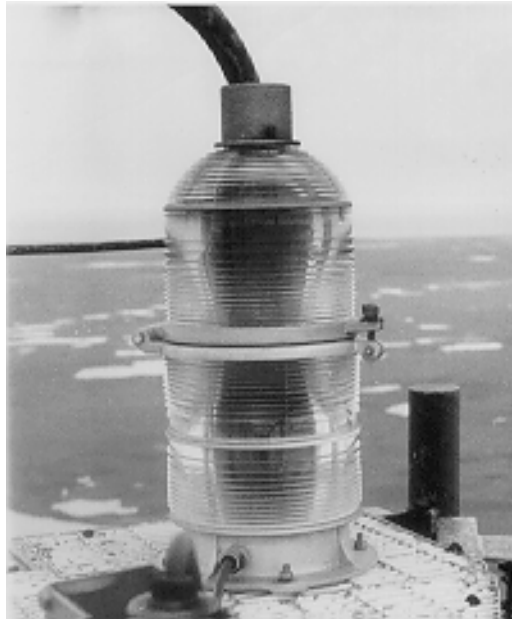

Figure 9-1 300mm coded beacon at top of 625ft Loran tower.

- a. Beacon Flashing Mechanism. Most flashing beacons are controlled by a solid state flasher mechanism. Any mercury tilt switch type flashing mechanisms shall be replaced by solid state flashers.
- b. Flashing Circuit Characteristics. Deficiencies present when an open-coil type isolation transformer is used in flashing beacon circuits include, relatively poor voltage regulation, low efficiency and high no-load magnetizing current. These deficiencies are due to the requirement for a large air space between the primary and secondary windings of the open-coil type isolation transformer. The open-coil construction results in satisfactory secondary leakage reactance as it limits secondary current surges in fixed circuits such as the obstruction light, or when the flasher is mounted on the secondary side of the transformer. However, the flasher units on most Loran-C tower lighting systems have been relocated to the primary side of the transformer causing peak current surges that resulted in rapid heating and failure of the mercury tilt-switches in the flasher units. Hence, to no avail, special dimming resistors were shunted across the beacon flasher terminals in an effort to solve this problem. Following extensive field testing, special peak current limiters were designed and developed by the lighting kit manufacturer to limit the high initial magnetizing current of the installed isolation transformer. Based on the principles of the current limiter, the manufacturer also designed a "stiffer", more

efficient, low-impedance, open-coil type isolation transformer. When ordering new or replacement transformers, always specify the location of the flasher mechanism to ensure proper design. Keep in mind that the rise in voltage during the beacon OFF interval can also result in an overvoltage condition on the lamps regardless of other features of the system. If this becomes a problem, one manufacturer recommendation is to install a 50-Farad, 400 VAC capacitor across the beacon leads, then adjust the transformer taps (with the beacon ON) to provide proper lamp voltage.

2. Fixed Obstruction Lights. A steady burning/fixed obstruction light is required at the top of obstructions less than 150 feet in height. For obstructions in excess of 150 feet in height, a steady burning/fixed obstruction light is required at the top level, and at one or more intermediate level of the obstruction.



Figure 9-2 Fixed obstruction lights with covers removed for inspection.

Although, single and double obstruction lights are available, the Coast Guard typically uses the double obstruction light which consists of two red Fresnel globes, each with medium screw-type lamp base mounted in a common housing. See Figure 9-2. The double obstruction light type fixture has an enclosed relay that allows for only one lamp to be lit at a time. The transfer relay mounted within the fixture housing monitors power to one lamp and automatically switches power to the second lamp if power loss is sensed in the first lamp. Lamps are typically 116 watt. Generally, three double obstruction light fixtures are installed, one on each leg, at each prescribed level on towers over 350 feet high.

3. Photo-Electric Relay. The photoelectric relay (a.k.a. photocell) is used to automatically energize and de-energize the lighting system. This concept is dependent upon light. Typically, when light levels are reduced to a preset level, the photocell switches and energizes the lighting circuit. When light levels are increased to a preset level, the photocell again switches to de-energize the lighting

circuit. The photocell sensitivity is typically factory set. However, there are photocells available that can be manually adjusted. Typical Coast Guard photoelectric relays consist of two basic components: the relay/switch mechanism and a remote mounted photocell.

4. Isolation Transformers. Isolation transformers provide a means of supplying 60 Hz power across the base insulator of an energized tower while providing high RF impedance between the tower and ground. The two basic types in use at Coast Guard installations are the open-coil, air-insulated, side arm-mounted (Figure 9-3), and the older oil-insulated types. Isolation transformers are provided with primary/secondary voltage ratios suited to the needs of the specific site. There are multiple taps on the windings that enable adjustment of the voltage supply to the secondary side.
5. Lighting System Wiring. Typical obstruction lighting kits furnished for a given tower contain components conforming to FAA specifications. Many of the original lighting kits contained type TW wiring in conduit. Where corrosion was a problem, lighting kits were modified to use Type RR-USE wiring which does not require conduit. Refer to section D below for current wiring requirements.



Figure 9-3 Isolation transformers on an energized tower.

6. Junction Boxes and Overcurrent Protection Devices. The remainder of a typical tower lighting system consists of junction boxes, and overcurrent protection devices. Weatherproof junction boxes are typically cast aluminum construction. Because of the obvious Life Safety issue, safety chains must be furnished with all junction box covers to prevent the cover from falling. Overcurrent protection devices can be a circuit breaker and/or a fused safety switch. Where isolation transformers are used, Safety Switches with slow-blow fuses are recommended because of the induced RF voltage that exists across the transformer's primary side even though the lighting system power supply is off. It is possible that once the lighting system is re-energized, a momentary high current surge may trip a circuit breaker.

Hence, the slow blow fuse could sustain this momentary surge. Typically, safety switches should be installed between the lighting system controls (source of power) and the primary coil of the transformer.

- D. New Lighting System Requirements. For new or replacement lighting systems, the following materials and features shall be provided in lieu of existing components. Most new lighting systems require little maintenance. However, because of the environments present at most Coast Guard tower sites, periodic inspection is required. The following features should be incorporated for new or replacement lighting systems:
1. Lighting cable should be type USE, style RR or equivalent, rated at 600 volts, secured directly to the inside of tower legs with approved tape. Cable shall be "sunlight resistant" and suitable for wet locations as described in the National Electric Code. **Conduit is no longer authorized.**
 2. Provide double obstruction lights at appropriate levels with raised encapsulated relays, stainless steel hardware and keeper chains that prevent the fixture lens and cover from falling. Specify Hughley & Phillips OB22A31TR1CG/ 5703 for cabling requiring a 3/4in diameter knockout. Knockout shall be located at the bottom of the fixture. For cabling requiring a 1in diameter knockout, specify H & P OB22A41TR1CG/5703 obstruction lights. For side entrance fixtures, use the same part number given above but change OB22 to OB24.
 3. Junction boxes should be UL Listed, NEMA 4X, cast aluminum housing, with watertight fittings, stainless steel screws, stainless steel keeper chain (to prevent cover from falling), and neoprene gasket.
 4. Whenever possible, lighting controls should not be mounted on the tower but should instead be mounted on panels at ground level.
 5. Provide solid state flashers.
- E. Lighting System Inspection and Maintenance. Prior to climbing a tower for inspection, it is recommended that the inspector/climber wear a backpack that includes replacement lamps, silicon grease, tools for opening junction boxes, tape, etc. It is also required that tools be fastened to the climber such that an accidental drop of the tool will not allow that tool to fall from the tower. Tower lighting systems should be inspected at least once per year (see Ch.3 ►C.1). Lighting system inspections should include the following:
1. For unmanned and remote tower locations all lamps or strobe flash tubes shall be replaced annually. Continuously manned stations shall annually replace strobe flash tubes and beacon lamps as well as any burnt out obstruction lamps in double obstruction light fixtures. When relamping a tower, the lenses and fixtures of the beacons and obstruction lights should be cleaned inside and out. Where double obstruction lights with transfer relays have been provided, the relay should be tested for proper operation, then sprayed with a fungicide and moisture-proof varnish. Where provided, vents and drain holes should be checked and cleaned as necessary. In some cases, drain holes have been enlarged with a countersink on the inside. Before

closing the lamp fixtures, the rubber or neoprene gaskets should be coated with silicone grease for weather proofing.

2. The voltage at each lamp socket should be checked and to comply with FAA standards, may not vary more than 3% from the rated lamp voltage.
3. Provide the following lamp types:
 - a. Obstruction Lamps. General Electric, incandescent, 116 watt, A-21 bulb, clear, medium screw base, 120 volt, C-9 filament, 6000 hour. NSN 6240-00-842-2887.
 - b. Beacon Lamps. General Electric, incandescent, 120-volt, 700-watt, PS-40 bulb mogul pre-focus base, C-7A filament, 6000 hour. NSN 6240-01-030-7071.
 - c. Supply of Lamps. Each tower unit should always have on hand a sufficient supply to re-lamp their entire tower
4. Replace any mercury switches in the flasher mechanism with a solid state flasher.
5. For double obstruction lights, test all transfer relays by unscrewing the primary lamp. Unscrewing the primary lamp should cause the relay to switch over to the secondary lamp. If the transfer takes place, the relay is good. If the transfer does not take place, then a new relay should be installed.
6. Clear vent and drain holes in obstruction light fixture.
7. Lubricate all neoprene gaskets in lighting fixtures and junction boxes with silicone grease. Do not leave excess grease inside the junction boxes or enclosures as it may trap moisture inside the housing or melt, blocking drain holes. Do not use silicone sealant in lieu of silicone grease.
8. Coat all screw threads with silicone grease before tightening.
9. Where needed, secure loose lighting cable to a tower member with tape as follows:
 - a. 2 turns of 2 inch Scotchwrap 1#50 around cable and tower member.
 - b. 3 turns of 1 inch Scotch filament tape #890 over the Scotchwrap.
 - c. 4 turns of 2 inch Scotchwrap #50 over the filament tape. Apply the last two turns with no tension.
 - d. Where extra holding strength is required, apply "Band-It" stainless steel banding over the last layer of tape.
10. The flasher unit and photocell should be checked and verified as operable at least monthly. The window of the photocell should be cleaned. Outdoor enclosures should be adequately sealed against moisture infiltration. Replace any mercury switches with solid state flashers.

11. The open coil type of isolation transformer should not require frequent inspection or extensive maintenance. The surfaces of the coils should be repainted with a waterproof varnish whenever cracking or other deterioration is noted. The coils should be oriented such that water does not drip from the upper coil to the lower. The oil-insulated base insulator type transformer is no longer specified. However, it is good practice to maintain the proper oil level in existing base insulators to prevent contamination from accumulating on the inner surfaces of the cylinder walls.
 12. The lighting system wiring should be checked at least every other year via an insulation resistance test with a 500-volt self-contained megger. Care should be taken to avoid the use of a megger which produces a higher voltage than the rated voltage of the conductor and connected equipment. Records should be maintained of all resistance tests so that any downward trend will be noted. It is important to establish initial insulation resistance values for any new installations; these will serve as a basis of comparison for subsequent tests. The insulation resistance should normally be at least one mega-ohm. To check the resistance of the tower wiring insulation, disconnect the conductors from the flasher, junction box, or transformer. Connect one lead of the megger to one of the conductors and the other lead to "ground" (the tower or junction box). This should be done for each individual conductor in the lighting system. It is not necessary to check the insulation resistance between conductor pairs unless problems are suspected. To isolate a point of low resistance, it will be necessary to repeat the megger check at each junction box. Tape or clamps securing lighting cable should be renewed as necessary.
 13. The conduit, junction boxes, fittings, terminals, etc. should be inspected for corrosion, proper support, and loose connections. Deficiencies are normally easy to correct and should be taken care of immediately. Corroded areas should be cleaned and painted. Terminal boards should be sprayed with a moisture-resistant varnish as required.
 14. Whenever the tower is de-energized for inspection or maintenance, the ball gaps should be checked to ensure that the proper distance is maintained between the ball gap spheres. The spheres should also be checked for contamination, protrusions, etc., and they should be cleaned as required. Where bonding straps are connected to the ball gap arms, they should be checked for loose connections and corrosion. The grounding of the ground side ball gap should be checked for electrical continuity and condition. Refer to Lightning Protection section below for further information on ball gaps.
- F. Lightning Protection. Each ungrounded tower is provided with a ball gap lightning protector (with or without a rain shield) for installation across the base insulator. See Figure 9-3. A one-time adjustment process can be used to establish the gap distances, and thereby provide a reasonable degree of protection for the transmitting equipment. The final gap setting should be recorded for future reference.
1. Adjustment of base insulator ball gap. The base insulator ball gap distance should be set approximately one-eighth inch greater than the maximum arc-over distance under full operating transmitting power.

This adjustment should be made during periods of high relative humidity using a trial and error method as follows:

- a. With the transmitter off and the tower grounded, the spheres should be wiped clean.
 - b. The ball gap arm connected to ground should be positioned so as to provide a gap of about 1 inch between the two spheres.
 - c. Clear all personnel from the immediate area of the tower base. Remove the grounding stick and energize the tower with full normal power.
 - d. If no arc-over is detected, turn off the transmitter, again ground the tower, and reduce the gap by one-eighth inch or less.
 - e. Again remove the grounding stick, energize the tower, and look for arc-over.
 - f. Repeat this process until arc-over is detected across the spheres. At this point, the gap should be increased by one-eighth inch to compensate for future contamination of the spheres.
2. Adjustment of isolation transformer ball gaps. Isolation transformers should have ball gaps installed. The ball gaps for the isolation transformers should be set one-eighth of an inch greater than the base insulator ball gap distance.
 3. Orientation of Ball Gap Spheres. Except where rain shields have been provided, the spheres should be placed so that drip water will not fall from one sphere to the other, and so that they will not come in contact should the tower twist about its vertical axis.
 4. Feedline. To further discourage travel of lightning into the transmitter building, antenna feedlines should have "vertical Z" shaped bends rather than straight lead to the tower (see Figure 9-4). This feature should be incorporated in all new or replacement feedlines.



Figure 9-4 Typical "z-feed" used at a LORAN Station.

5. Grounding. Lightning prefers a short, straight path to ground. This should be considered when mounting and connecting the lower arm of ball gaps. A better ground may be attained by driving galvanized well pipes into the water table near the base of the tower and running direct leads to these pipes from the lower ball gap arms; this may only be necessary where lightning is a particularly frequent problem.

APPENDIX A. GLOSSARY

A

ACSR CABLE - A high conductivity, low-weight stranded cable having a galvanized steel or aluminum-coated strand as an inner core surrounded by solid aluminum wires. Problems with low outer wire strength and failure at the connectors makes it less desirable than alumoweld cable.

ALUMINUM TOWERS - Towers whose structural members are made of aluminum base alloys with high resistance to atmospheric corrosion.

ALUMOWELD CABLE - A proprietary aluminum coated steel cable (ACSC) widely used on guyed towers. The aluminum coating is electrically bonded to the steel strands during fabrication, and provides a higher resistance to corrosion than galvanizing. This cable is widely used for LORAN tower TLE's.

ANCHOR ARM - A steel rod, channel, or other member or assembly, one end of which is secured in the ground or in a concrete guy anchor, which provides an attachment point for the guy or guys.

ANCHOR BAR - A "U" shaped steel bar or eyebolt which is set into the tower base pedestal or guy anchor, and which is used to attach hoisting equipment, or guy tensioning or rigging gear. See Figure 4-4.

ANCHOR PIN - A pin that is used to attach an equalizer plate or a guy link to an anchor arm when the plate is not welded to the arm.

ANTENNA - Any device used to transmit and/or receive electromagnetic waves.

ANTENNA SUPPORT TOWER - A non-energized tower which is used to hold an antenna, or part of an antenna, but which is not part of the electrical antenna.

ANTENNA TOWER - A tower that is used as the transmitting antenna, or as part of an antenna, such as the 625 foot Loran-C transmitting antenna tower or DGPS tower. These towers are electrically isolated using base insulators. Also known as energized towers.

ATMOSPHERIC CORROSION - Usually the result of an alternate wetting or drying process, with the corrosive attack taking place when the surface is wet. This can be expected to occur to a somewhat greater extent on the seaward portion of the tower elements.

AUTOPLUMB - A special optical instrument used at the base of a tall tower to determine tower deflection.

AWAC CABLE - An alumoweld-aluminum conductor cable which consists of both alumoweld strands and solid aluminum strands in a symmetrical interweave. The combination offers increased conductivity over alumoweld cable, but at some loss in strength.

B

BALL-GAP LIGHTNING PROTECTOR - A device which includes two spherical surfaces at the end of adjustable arms. The ball gap is adjusted so that any lightning-induced current in the antenna tower or the antenna tower lighting system will arc across the gap to ground, thus protecting the transmitter or

power supply without grounding the tower base insulator or lighting system isolation transformer.

BASE INSULATOR - A device consisting of one or more porcelain cones or cylinders which is used to support and insulate a tower from the ground.

BASE PEDESTAL - The concrete pedestal or foundation which supports a tower; also referred to as a "base pier".

BASE PLATE - The horizontal steel plate which rests on the top of the base insulator or insulators; or, a metal plate with a thick base pad of lead or zinc between the base pedestal and the base insulator.

BEACON LIGHT - A flashing light placed at prescribed intervals throughout the tower height in accordance with FAA standards, which is used to mark the location of a possible hazard to aerial navigation.

BEARING BOLT (Also known as body-bound or interrupted rib bolt) - A bolt which is designed to be driven into position, thereby completely filling the bolt hole and eliminating possible slippage of the connected plates.

BIRD CAGE, BIRD-CAGING - A condition wherein the outer wires or strands of a cable separate and expand outwards from the core. This can be caused by corrosion of the inner core or foreign matter or improper handling of the cable. This condition can sometimes be removed by twisting and tensioning the cable, provided all dirt or other matter is cleared away. Bird-caging does not materially affect the strength of cable used for standing rigging, such as tower guys, but should not exist in running rigging.

BONDING STRAP - A braided or solid metal conductor, usually copper or aluminum, which is used to provide electrical continuity between two adjacent items. It is generally used where a connection between two conductors is likely to develop high resistance or arcing (i.e., at a shackle, or insulator yoke plate, or some leg flanges).

BREAK-UP INSULATORS - Ceramic or porcelain insulators which are inserted in guys at a specified spacing to keep the length of individual guy segments short enough so that guys will not re-radiate signals and to reduce the build up of triboelectric charges. Often referred to as "johnny ball insulators".

BRIDGE SOCKET - A special potted socket fitting used at the lower end of bridge strand structural guys to connect the guy to its hairpin.

C

CABLE - A generic term used to describe guy strand as well as the exposed lighting system wiring on the lighted towers.

CABLE BIGHT - A loop in the end of a cable (sometimes the term refers to the size of such a loop).

CABLE CLIP - A "U-bolt" or "J-bolt" which is used to fasten two cables together or to hold a loop in the end of a cable. Cable clips are not recommended, and are not authorized for permanent use in any structural application on tower guys and radials.

CABLE END FITTING - A guy-grip dead end, socket, swaged or compression fitting used at the end of a cable, cable segment, or fiberglass insulator to form a loop or otherwise enable connection to a tower, shackle, turnbuckle, or other component.

CABLE GRIP - A device used to temporarily hold a guy cable for erection or tensioning purposes. The common grip usually consists of two jaws, plates, or cams, which exert friction pressure against the cable as the grip is pulled axially along the cable. Special material or cover plates of copper or aluminum are used for alumoweld or similar "soft surface" cable to minimize damage to the cable.

CAM-ACTION CABLE GRIP - A device which is used in tensioning cables. It is designed so that the pressure exerted against the sides of the cable increases (through cam action) as the tension increases. (See CABLE GRIP).

CHAIN HOIST - A manually operated lifting device that uses a continuous chain looped through a series of pulleys.

CLEVIS - A U-shaped metal piece with a hole in each end through which a pin or bolt is run.

CLOSED END INSULATOR - A compression-type porcelain, fail safe guy insulator in which the interlocking guy loops pass through holes in the insulator. The insulator prevents the interlocked cables from touching each other.

"CLOVER-LEAF" RIGGING - A system for tensioning guys during tower erection in which all guys at a given level are pulled simultaneously by a single cable, automatically equalizing guy tension.

COFFING HOIST - (See "CHAIN HOIST") A proprietary name for a variety of hoisting devices. The term is often used to refer to a lever-operated hoist which uses a discontinuous chain.

"COME-ALONG" - A loosely used term for a variety of pulling or hoisting devices. (The term is also the proprietary name of a specific type of a lever-operated spur-gear driven hoist).

COMPRESSION CONE INSULATOR - A type of porcelain guy insulator in which a hollow porcelain cone is mounted within an open frame, with one end seated against the frame. An eyebolt extends through the hollow center of the cone. One guy segment is attached to the frame and the other guy segment is attached to the eyebolt.

COMPRESSION FITTING - A cable end fitting, made of relatively soft metal alloy, which is deformed under pressure to form a permanent loop in the cable. It is also known as a press fitting.

COPPERWELD CABLE - A proprietary copper-coated steel cable wherein the copper-coating is permanently bonded to the steel strands during fabrication.

CORONA - An electric discharge resulting from a breakdown (ionization) of a gas dielectric (i.e., a discharge into the air from a high voltage conductor). Corona is likely to occur at the top of an energized tower, or at any projecting object on a tower.

CORONA RING - (See "CORONA") - Any circular or curved device which extends above a tower or outside a projecting object on a tower, and whose purpose is to prevent corona. It functions as a conductor between the parts of the tower to which it is attached, preventing the accumulation of unequal electrical charges in those parts. It also functions as a distributive capacitor, equalizing the charge applied to the air. See also GRADIENT RING.

COTTER PIN - A split pin that is fastened in place by spreading apart its ends after it is inserted. It is used to prevent the loss of a shear pin from its fitting, such as in a turnbuckle or in a shackle.

D

DEFLECTION - Horizontal displacement of a tower from true vertical.

DEFORMATION - A permanent bend or kink in a structural member of a tower, exhibited by a permanently formed short radius bend, or series of closely grouped bends.

DIAGONAL - A term used to describe those structural members connecting adjacent legs of a tower. The rods or channels are usually connected at an angle to the legs or diagonally between the legs.

DISPLACEMENT CURRENT - A current that flows over the surface of the body when an individual in a fluctuating electromagnetic field is grounded or is near a conductor which is at a different potential from his body.

DYNAMOMETER - A device for measuring force or power (See also "SERIES DYNAMOMETER" and "SHUNT DYNAMOMETER").

E

EQUALIZE PLATE - A metal plate that is used to provide more than one turnbuckle attachment point on a single anchor arm. The plate may be attached to the anchor arm by an anchor pin or by welding.

EXFOLIATION - The corrosion of an alloy plate where the corrosion product expands, causing a laminated or flaked appearance.

EYEBOLT - A bolt used with a closed loop head. It is often used to attach a guy to a compression cone insulator.

F

FAIR LEAD - A block or ring serving as a guide for running rigging to keep it from chafing.

FIBERGLASS INSULATORS - An insulator that has extremely high dielectric strength and is attached between the tower and the structural guys, and at the ends of the top loading elements where its insulating characteristics are most needed. The insulator is in tension when installed. Often referred to as strain insulators.

FLASHER - A device or control which turns the electrical power to a beacon light "on" and "off" at a specified frequency, giving the beacon its flashing characteristic.

FLASH TUBE - The "lamp" portion of a medium or high intensity (strobe) lighting system.

G

GIN POLE - A special rig, varying from a simple steel pole to a large space frame truss, depending on the size of the tower, which is used to erect the upper sections of a tower without the use of a crane or derrick. The gin pole is equipped with swivel heads and pulleys which, during operation, are commonly rigged with wire rope lifts and jumping lines which lead to a double-drum winch on the ground.

GIRT - A structural compression member fastened between the legs of a tower, such as the horizontal cross pieces.

GRADIENT RING - A device shaped like a wheel or an open cone which is used as a distributive capacitor. Gradient rings are often installed at the hot ends of guy insulators to equalize the distribution of electrons over the end of the insulator, thereby reducing the possibility of arc over. See also CORONA RING.

GUSSET - A metal plate used to reinforce a joint or used to provide leg attachment points for tower diagonals and girts.

GUY - A generic term for the cable or rope, either temporary or permanent, which is connected between a tower and the ground to support the tower in a vertical position.

GUY ANCHOR - Any device used to fasten a guy to the ground.

GUY GRIP DEAD END - A cable end fitting which consists of several high tensile strength wires. The wires are bent near the center to form a loop, and the legs are preformed and laid so that they will tightly clamp a cable when they are wrapped around it. (Commonly called preformed guy grips, or PLP's).

GUY INSULATOR - Any device which is used to prevent current from flowing through a guy. Guy insulators are generally made of either porcelain or fiberglass.

GUY SEGMENT - A portion of a guy between insulators and/or fittings.

GUY TENSION - (See also INITIAL TENSION) - The amount of axial force in a guy as measured at the ground end of the guy. It is usually stated in pounds.

GUY TENSION CALIPER - A special scissor-shaped metal device incorporating a tensiometer. It is used to directly measure tension in guys that are connected to anchors with turnbuckles.

GUYED TOWER - A tower that is supported by guy cables or ropes attached at one or more levels.

H

HAIRPIN - A large, threaded U-bolt used on the taller tower guys to position the upper jacking plate, and to transfer tension to the anchor when adjusting guy tensions with the hydraulic jacking device.

HIGH-STRENGTH BOLT - A structural steel bolt usually made to ASTM A325 specifications.

HYDRAULIC JACKING DEVICE - A heavy duty hydraulic jack consisting of two hydraulic rams, a pump, hose and gage, which is used on high tension guys such as backstays on SLT/TIP Loran towers and towers over 1000ft to measure tensions when erecting or adjusting the guys.

I

IMPULSE CHARGE - A static charge caused by a lightning discharge.

INITIAL TENSION - The axial force or load recommended by the tower designer to be applied to a guy under no load (i.e., "no wind" and "no ice") conditions.

INTERRUPTED-RIB BOLT - A bolt with a serrated shank to prevent rotation and slippage of connections. (See "BEARING BOLT").

ISOLATION TRANSFORMER - An air-insulated, open coil, or oil filled power transformer which is capable of withstanding high voltages between windings. It provides a low-capacity means of supplying electrical power across the base insulator on antenna towers without grounding the structure.

J

JACKING LEGS - Vertical columns placed between the jacks and the jacking pads when raising a tower to replace the base insulator.

JACKING PADS - Horizontal plates, welded to the base section of a tower, designed to carry the weight of the tower if it is necessary to raise the tower to replace the base insulator.

JACKING PLATES - Steel plates attached to the tower base pedestal that are used as bases for the jacks if it is necessary to raise the tower to replace the base insulator.

JAM NUT - A thin nut installed under the regular nut on a bolt to prevent loosening of the nut or bolt. It is a form of lock nut.

K

KLEIN GRIP, KLEIN-CHICAGO GRIP, KLEIN-HAVENS GRIP - Proprietary names which refer to a variety of lever action and cam action cable grips. (See "CABLE GRIP").

L

LAMP - A general term used to describe the light bulb in a tower lighting fixture.

LAY - The direction of rotation or helix of either the wires in a strand or the strands in a rope.

LOCK NUT - Any nut with a special locking feature that prevents or restricts its rotation. ("ANCO" is a commonly used lock nut).

M

MAINTENANCE - Routine, recurring work, such as painting and lamp replacement, which is required to keep all tower structural elements, including guys, anchors, insulators, and electrical components in such a condition that they

may be continuously utilized at their original or design capacity and for their intended purposes.

MERCURY TILT SWITCH - A plastic, tube-shaped mercury filled switch used in mechanical flashers to flash the beacon circuit. The mercury rolls back and forth within the switch as it is tilted up and down to provide the on-off switch capability.

MULTIPLE-CYLINDER BASE INSULATOR - A type of tower base insulator which uses two or more porcelain cylinders between parallel steel plates.

O

OBSTRUCTION LIGHT - A single or double light fixture located at various levels on a tower in accordance with FAA regulations. Obstruction lights have a fixed characteristic.

OPEN END INSULATOR - (Also known as a "Johnny Ball" Insulator). A failsafe compression type porcelain guy insulator in which interlocking guy loops rest in grooves in the surface of a porcelain insulator. The insulator prevents the interlocked cables from touching each other.

P

PERSONAL FALL ARREST SYSTEM - A system worn by a climber to break a fall; consists of a safety climb device, connectors, lanyards, deceleration device and body harness.

PHOTO-ELECTRIC RELAY - A control or device used to automatically activate and deactivate the entire tower lighting system. The photo-electric relay utilizes a photocell which is preset at the factory to operate the lights between dusk and dawn as required by FAA standards.

PRECIPITATION CHARGE - A static charge caused by precipitation (rain, sleet, etc.).

PROTECTIVE BARRIERS - A permanent type single gated fence or wall, preferably constructed with non-metallic materials, to protect the towers and anchors from vehicular damage as well as to guard against injuries to personnel.

PULL-OFF PLATE - A plate that is attached to a tower leg and used as an attachment point for a guy.

Q

QUESTAR TELESCOPE - A high-powered, tripod mounted telescope used to inspect inaccessible portions of the tower and guy systems from the ground. Photographs can be taken using a special camera attachment.

R

RADIAL, RADIAL GUY - The uppermost guy assembly on an antenna tower which consists of the transmitting elements (top-loading elements) and the insulated supporting guy connecting the transmitting elements to the ground. A radial guy also acts as a structural guy for the tower.

RADIAL GUY ANCHOR - An anchor that is used to attach the end of a radial guy to the ground.

REPAIR - Restoration of a tower structural element or electrical components to a condition substantially equivalent to their original or design capacity by replacement, overhaul or reprocessing of constituent parts or materials.

REST PLATFORM - A platform which is installed to provide a resting location for an individual who is climbing the tower ladder. It is also used as a work platform at levels where maintenance work is likely, such as the tower top and at obstruction lighting levels.

RIGGING - All of the various cables that secure towers and other masts are collectively referred to as rigging. Cables or wires bracing the tower comprise the standing rigging. Those used for hoisting or adjustments make up the running rigging.

RIGGING LOOP - (See "ANCHOR BAR")

S

SAFETY CLIMBING DEVICE - A device that aids or prevents a climber from falling off a structure while climbing. It consists of a rigid metal rail up the center of the ladder or climbing surface, and a sliding unit that will move easily up or down the rail but that will automatically lock if the climber falls.

SAFETY RAIL - A continuous channel or notched pipe that is attached to the center of a ladder or climbing surface.

SAFETY WIRE - A wire loop that is threaded through a guy turnbuckle or screw type shackle in a manner that will prevent the turnbuckle or shackle pin from loosening.

SELF-LOCKING NUT - Any lock nut which incorporates a device that increases the amount of torque required to loosen the nut.

SERIES DYNAMOMETER - A device used for measuring the tension in guys by placing it between the guy and the anchor in such a manner that it carries the full axial load. Loads are read directly from a dial, which is calibrated in pounds.

SHACKLE - A "U" shaped (chain) or horse-shoe shaped (anchor) attaching device with a removable pin or bolt. Shackles are used to attach guys to anchors and towers, or as connectors within the guy assemblies.

SHEAR PIN - A pin or bolt that connects or transfers load between two fittings, such as in a turnbuckle or shackle.

SHUNT DYNAMOMETER - A device used to measure the tension in guys. It operates on the basis of measuring the amount that a guy deflects (between two fixed points) upon application of a given amount of pressure. The instrument must be calibrated for each specific type and diameter of guy which is to be checked. Readings obtained must be interpreted by using a special calibration chart. Some tower manufacturers incorrectly refer to a shunt dynamometer as a "tensiometer".

SINGLE-CYLINDER BASE INSULATOR - A type of base insulator which uses a single porcelain cylinder as the insulating element.

SLIDING DEVICE - The portion of the safety climbing device that slides on the safety rail, and locks on the rail should the climber fall.

SLOPE MEASURING DEVICE (SMD) - A calibrated triangular-shaped device with a built-in bubble level or dial indicator used to measure the slope of a guy. The slope is then converted to guy tension through the use of pre-developed curves or graphs.

SOCKET FITTING - A cable or fiberglass insulator end fitting that uses a tapered conical socket into which the cable end is inserted. The socket is then filled with a potting compound. (Socket fittings are also known as potted fittings).

SOIL CORROSION - A condition characterized by poor aeration and high acidity, electrical conductivity, salt, and moisture content. The degree of corrosion of metals in contact with soil is influenced by the characteristics or properties of the soil.

SPOOL - A solid steel spacer used between the shear pin and take-up U-bolt on 1,000 foot or taller tower guy anchors. The spool serves the same purpose as a thimble.

SPUD WRENCH - A wrench with jaws at one end, and a point at the other end, which is commonly used in structural steel assembly. The pointed end can be used for centering bolt or rivet holes, as with a pry bar, temporary fastener, etc.

STATIC DRAIN DEVICES - A device installed in AN/FPN-44 and AN/FPN-45 Loran-C transmitter couplers to ground static charges when the tower is de-energized.

STATIFLUX - A trade name of the MagnaFlux Corporation applied to the materials and equipment for use with the electrified particle inspection method.

STRAIN INSULATOR - A porcelain or fiberglass insulator in which the insulating element carries a tension load.

STRAY-CURRENT CORROSION - A form of corrosion that occurs on subsurface metals, and results from the electrical current which has a source external to the affected metal structure. This type of corrosion is generally associated with direct current.

STRUCTURAL GUY - A guy whose function is to assist in supporting the tower structure.

STRUCTURAL MEMBER - A distinct part of a structure, such as a tower leg, a horizontal brace, etc., which bears a compressive or tensile load.

SWAGED FITTING - A cable end fitting in the form of a sleeve that is slipped over a cable end, and then crimped.

T

TAKE-UP "U" BOLT - A "U" Bolt with long threaded legs used as both a tensioning device and to connect the structural guys on 1,000 foot or taller towers to the link bars on the guy anchors.

TENSIOMETER - (See "SERIES DYNAMOMETER")

TENSION - The axial load, force or pull in a tower diagonal, guy, guy component, or anchor arm.

THIMBLE - A device that fits inside a cable end loop to maintain a proper, fixed radii in the cable loop under load.

TLE SUPPORT GUY - The lower, insulated portion of a radial or radial guy which connects the TLE to the radial anchor and maintains the spatial position of the TLE.

TOP LOADING ELEMENT (TLE) - The upper, energized portion of a radial or radial guy on a Loran and DGPS antenna towers. The TLE is bonded to the tower and insulated from its supporting guy by a strain insulator.

TOWER - a permanent vertical structure, or structure that is more vertical than horizontal, that is energized or non-energized, guyed or free standing, and exceeds 20 feet in height.

TOWER ALIGNMENT - (a) Technically, a relative measure of the extent to which a tower is deflected from true vertical; (b) the process of adjusting a tower to change its deflection; and (c) a general term used to describe both the deflection and the twist of a tower.

TOWER BASE - The entire structure which supports the tower, including the pedestal, base insulator, pivot bearing, etc.

TOWER DEFLECTION - The horizontal displacement of a tower from true vertical.

TOWER, SMALL - Any tower less than 300ft in height.

TOWER, TALL - Any tower 300ft in height or greater.

TOWER TWIST - The rotation of a tower or portion of a tower about its vertical axis.

TRANSIT - A surveying instrument used to accurately determine, measure, or observe a straight vertical or horizontal line or surface; used to measure tower alignment.

TRIBOELECTRIC CHARGE - A static charge caused by friction, usually wind friction.

TURNBUCKLE - A tensioning device which uses a rotating link that is threaded at one or both ends, and which becomes an integral part of the assembly that is being tensioned. It is the most commonly used method to connect tower guys to anchors.

U

UPSET THREADED EYEBOLT - An eyebolt whose threaded portion has a greater diameter than the shank. It is used on some compression cone insulators. (See "EYEBOLT").

V

VISUAL SAG METHOD - A method of arranging a sighting device parallel (and tangent) to a guy at the guy anchor to measure the guy catenary and determine guy tension.

W

WARNING MARKERS - A permanent type single gated fence or post, preferably constructed with non-metallic materials, to mark guy anchors and to avoid vehicular damage and injuries to personnel.

WIRE ROPE - A form of metal cable which consists of multiple strands (each made up of several wires) laid helically around a center strand. Wire rope is more flexible than wire strand, and is used mainly for running rigging.

WIRE STRAND - A form of metal cable composed of individual wires laid helically about an axis or center wire to produce a symmetrical single strand. Strand is used for guying towers since it has a higher modulus of elasticity than wire rope and, size for size, is stronger by some 30 percent.

Y

YOKE PLATE - A special galvanized steel plate typically used to connect a pair of fiberglass insulator rods to a tower or to a guy segment.

APPENDIX B. TOWER INSPECTION REPORTS

This Appendix contains a selection of forms which are suggested for use in documenting tower inspections. Most reports contain narrative sections and photographs which will supplement the information on these forms. Civil Engineering Units are encouraged to develop standardized forms which are tailored to local conditions, using forms in this Appendix as a guide. Two types of inspection reports are highlighted in this Appendix. The first report (pages B-2 thru B-5) is a simplified format and is well suited for use with small towers. The second report format (starting on page B-6) is well suited for tall towers but may be used for towers of any height.

All tower inspection reports need to include at a minimum the following information:

1. Cover Sheet-Station Name
Tower height, model and purpose
Inspection Date
Inspector name and signature
2. General Comment - Give a brief summary of the overall tower condition description upon completion of the current inspection.
3. Initial Tower Condition - List discrepancies not corrected from the last report and any new discrepancies found during the current inspection. Provide initial alignment, twist, and tension readings, including plots of all of these readings. Provide the initial lighting system diagram and data.
4. Previous Discrepancies Corrected - List and briefly explain discrepancies corrected from the previous report, prior to the current inspection.
5. Maintenance Accomplished - Give a summary of routine maintenance and discrepancy corrections accomplished during the current inspection.
6. Completed Tower Condition - Give a final detailed tower condition description, and provide final readings and plots of the alignment, tensions and twist readings. Include the final lighting system diagram and data.
7. Recommended Actions - List recommended actions and dates by which action should be taken to correct discrepancies addressed and left uncorrected upon completion of the current inspection.

Maximum use should be made of color photographs to show normal, typical, and unusual conditions. When inspection work is accomplished by a contractor, the servicing CEU should review the Inspection Report and add comments, narratives, and plots as necessary.

REPORT OF SMALL TOWER INSPECTION

UNIT/LOCATION: _____

TOWER HEIGHT: _____ TOWER USE: _____

TOWER MANUFACTURER: _____

TOWER MODEL NUMBER: _____

TOWER INSTALLATION DATE: _____

INSPECTING UNIT: _____

INSPECTORS: _____

DATE OF INSPECTION: _____

WEATHER: _____

ANTENNAS ON TOWER: TYPE MODEL ELEVATION

_____	_____	_____
_____	_____	_____
_____	_____	_____
_____	_____	_____
_____	_____	_____

INSPECTOR'S SIGNATURES: _____

TOWER INSPECTION SUMMARY

TOWER: _____

DATE: _____

INSPECTION ITEM	SAT.	UNSAT.*	N/A
1. ENCLOSURE/FENCE/GROUNDS			
2. TOWER FOUNDATION			
3. ANCHOR BOLTS			
4. GROUND STRAPS			
5. TOWER BASE INSULATOR			
6. LEGS			
7. DIAGONALS/HORIZONTALS			
8. BOLTED CONNECTIONS			
9. WELDED CONNECTIONS			
10. SECTION CONNECTIONS			
11. LADDER AND SAFETY RAIL			
12. PAINT/GALVANIZING			
13. ANTENNAS			
a. MOUNTING HARDWARE			
b. ORIENTATION			
c. RADIATING ELEMENTS			
14. TRANSMISSION LINES/FEEDS			
a. CONNECTIONS			
b. INSULATION			
15. LIGHTING SYSTEM			
16. GUY ANCHORS			
17. GUY WIRES (include tensions)			
18. GUY INSULATORS			

*COMMENTS ARE REQUIRED FOR ALL UNSAT CONDITIONS.

EXECUTIVE SUMMARY

GENERAL

(describe tower, location, date of inspection, a summary statement of tower condition and list inspector names)

STRUCTURAL MEMBERS

(Insert general comments about tower paint and galvanizing condition, condition of structural members and structural integrity).

ALIGNMENT AND TWIST

(Insert summary results of tower verticality -- i.e. "alignment and twist are within tolerances at all levels" and a statement of any significant changes from previous inspection.)

LIGHTING SYSTEMS

(Insert summary of lighting system condition and lamp replacement).

GUY AND GUY HARDWARE

(Insert summary of guy and guy hardware condition, as well as statement of guy tensions -- i.e. "All guy tensions were within tolerance").

ANCHORS AND FOUNDATIONS

(Insert summary statement of guy anchor and foundation condition)

INSULATOR SYSTEMS

(Insert summary of base insulator and guy insulator conditions)

GROUNDING SYSTEMS

(Insert summary of grounding system condition)

RECOMMENDATIONS

CONTRACTOR ACTION *(To be accomplished during next contracted maintenance)*

- 1.
- 2.
- 3.
- 4.

CEU ACTION

- 1.
- 2.
- 3.
- 4.

UNIT ACTION

- 1.
- 2.
- 3.
- 4.



STRUCTURAL MEMBERS

INSPECTION CHECKLIST (Comment on all items that are answered "NO.")

1. YES/NO 1. Is an adequate amount of galvanizing and/or paint intact to inhibit corrosion? *Note: Pay particular attention to the weather side.*
2. YES/NO 2. Is at least 30% of orange/white aviation warning paint intact?
3. YES/NO 3. Is all hardware securely in place and intact? *Note: Loose structural nuts and bolts should be replaced entirely, not retightened.*
4. YES/NO 4. Are all replacement nuts ANCO self-locking or a similar type?
5. YES/NO 5. Is the ladder and safety rail in good condition?
6. YES/NO 6. Are structural members free of deformation? *Note: The CG Tall Tower Coordination Center shall be notified immediately by message of pronounced bowing in diagonals.*
7. YES/NO 7. Are fillet weld areas free of cracks?
8. YES/NO 8. Are all bolt and pin connections tight?
9. YES/NO 9. Is the tower free of galvanic corrosion? *Note: If "NO," note which type of metals are involved.*

NARRATIVE REMARKS

(Insert comments about any item marked NO, as well as other amplifying information).

ALIGNMENT AND TWIST

INSPECTION CHECKLIST (Comment on all items that are answered "NO.")

1. YES/NO 1. Are tower guys free of ice?
2. YES/NO 2. Are the ground winds less than ten knots?
3. YES/NO 3. Is there an equal temperature distribution along the tower? *Note: This is best accomplished during cloud cover or early morning.*
4. YES/NO 4. Are twist and alignment measurements taken at the same time or during the same conditions?
5. YES/NO 5. Is tower deflection within allowable values? *Note: Tower plumbness and guy tensions are the primary indicators of tower stability.*
6. YES/NO 6. Has tower deflection experienced relatively little change from the last inspection?
7. YES/NO 7. Is tower twist within allowable values? *Note: Maintaining guy tension tolerances and balance takes precedence over counteracting twist and alignment discrepancies.*
8. YES/NO 8. Has tower twist experienced relatively little change from the last inspection?

NARRATIVE REMARKS

(Insert comments about any item marked NO, comparison comments to previous readings as well as other amplifying information. Include summary of alignment and twist worksheets enclosed).

LIGHTING SYSTEMS

INSPECTION CHECKLIST (Comment on all items that are answered "NO.")

1. YES/NO 1. Have all lamps been replaced and tested satisfactory?
2. YES/NO 2. Do all transfer relays test satisfactory?
3. YES/NO 3. Do all light fixtures have neoprene gaskets in good condition?
4. YES/NO 4. Have all gaskets and screws been coated with silicone grease?
5. YES/NO 5. Is all loose wiring properly taped to the tower structure? *Note: Use of conduit is no longer authorized.*
6. YES/NO 6. Is all lighting cable type RR and rated at a minimum of 600 volts?
7. YES/NO 7. Are voltage readings within allowable values?
8. YES/NO 8. Are megger readings within allowable values?

NARRATIVE REMARKS

(Insert comments for any item marked NO as well as other amplifying information. Include lighting system inspection worksheet).

GUYS AND GUY HARDWARE

INSPECTION CHECKLIST (Comment on all items that are answered "NO.")

1. YES/NO 1. Are guys free from being fouled or crossed?
2. YES/NO 2. Are all big-grips intact and free of unraveling?
3. YES/NO 3. Are all guy tensions within design guidelines? *Note: Tower plumbness and guy tensions are the primary indicators of tower stability.*
4. YES/NO 4. Are guy tensions less than approximately 40% of their breaking strength? *Note: This safety factor allows for high winds and icing conditions.*
5. YES/NO 5. Are all guys free of frays or burrs?
6. YES/NO 6. Are all turnbuckles and associated hardware intact and free of corrosion?
7. YES/NO 7. Are at least 2-3 threads visible within the body of all turnbuckles? *Note: Turnbuckles should be at 40%-60% of their take-up to allow for tensioning and slackening.*
8. YES/NO 8. Is safety wire in place on all turnbuckles?
9. YES/NO 9. Are all cotter pins in good condition?
10. YES/NO 10. Are turnbuckle threads greased or similarly protected from corrosion?
11. YES/NO 11. Is the use of cable clips and saddle clamps prohibited for structural applications?
12. YES/NO 12. Are guy cables free of rust or other corrosion?
13. YES/NO 13. Are shackles free of deformations?
14. YES/NO 14. Are safety shackles used at places where vibrations can be expected?

NARRATIVE REMARKS

(Insert comments about any item marked NO as well as other amplifying information. Include guy tension summary).

ANCHORS AND FOUNDATIONS

INSPECTION CHECKLIST (Comment on all items that are answered "NO.")

1. YES/NO 1. Is all foundation concrete free of cracks?
2. YES/NO 2. Is steel reinforcement protected from the atmosphere and subsurface?
3. YES/NO 3. Are steel anchor arms free of corrosion?
4. YES/NO 4. Is steel in contact with the subsurface maintained with a zinc-based primer and paint?
5. YES/NO 5. Are foundations free of evidence of lateral or vertical movement? *Note: Markers shall be placed near foundations suspected of movement and measurements taken regularly.*
6. YES/NO 6. Is there adequate drainage away from all foundation piers and anchors?
7. YES/NO 7. Is deep-root vegetation prevented from growing near all foundation piers and anchors?
8. YES/NO 8. Are anchors free from evidence of soil corrosion? *Note: If no, note appropriate characteristics of soil.*

NARRATIVE REMARKS

(Insert comments about any item marked NO as well as other amplifying information).

INSULATOR SYSTEMS

INSPECTION CHECKLIST (Comment on all items that are answered "NO.")

1. YES/NO 1. Has the integrity and level of oil in the base transformer been maintained?
2. YES/NO 2. Is the sealing compound of the base insulator intact?
3. YES/NO 3. Is the base insulator clean?
4. YES/NO 4. Are all guy insulators free of cracks or chips?
5. YES/NO 5. Are all guy insulators free from being excessively cocked?
6. YES/NO 6. Does a statiflux of the base insulator show satisfactory results?
7. YES/NO 7. Are all fiberglass rod insulators free of significant twist?
8. YES/NO 8. Are all fiberglass rod insulators free of a developing pattern of resin deposits? *Note: This suggests electrical travel along the fiberglass rod.*
9. YES/NO 9. Are all fiberglass rods free of signs of ultraviolet deterioration?

NARRATIVE REMARKS

(Insert comments about any item marked NO as well as other amplifying information.)

GROUNDING SYSTEMS

INSPECTION CHECKLIST (Comment on all items that are answered "NO.")

1. YES/NO 1. Is the tower free of signs of electrical arcing? *Note: This includes burn spots, humming, snapping, or abnormal guy resonance.*
2. YES/NO 2. Are lightning ball-gaps 1/8th-inch greater than the maximum arc over distance?
3. YES/NO 3. Are lightning ball-gaps oriented to prevent a short circuit by dripping rain water?
4. YES/NO 4. Are lightning ball-gaps oriented to prevent closure by tower twist?
5. YES/NO 5. Are grounding straps intact for an adequate distance into the subsurface? *Note: A straight line to the water table is ideal.*
6. YES/NO 6. Is the antenna feedline from the transmitter building z-shaped to discourage lightning travel?

NARRATIVE REMARKS

(Insert comments about any item marked NO as well as other amplifying information).

STRUCTURAL INSPECTION

Tower:

Date: <input style="width: 80%;" type="text"/>	Temp: <input style="width: 80%;" type="text"/>
Time: <input style="width: 80%;" type="text"/>	Wind: <input style="width: 80%;" type="text"/>
Inspector: <input style="width: 80%;" type="text"/>	Weather: <input style="width: 80%;" type="text"/>

INSPECTION ITEM	TOWER SECTION NUMBERS																										
	1	2	3	4	5	6	7	8	9	10	11	12	13	14	15	16	17	18	19	20	21	22	23	24	25	26	
LEGS																											
HORIZONTALS																											
DIAGONALS																											
GUSSETS																											
FLANGES																											
BOLTS																											
PAINT/GALVANIZING																											
LADDER/SAFETY RAIL																											
PULL-OFFS																											
SHACKLES																											
YOKE PLATES																											
STRAIN INSULATORS																											
GUY CABLES,GRIPS																											
THINBLES																											
BONDING																											
PLATFORMS																											
OBSTRUCTION LIGHTS																											

Condition Codes:

A = Condition Entirely Satisfactory	C = Problem Requiring Immediate Attention Exists
B = Minor Problem Exists; or Potentially Major Problem Developing; or Problem was corrected by the Inspector(s)	D = Other

NOTE: See summary inspection notes within this report for all items listed as "B" above

ALIGNMENT BY TRANSIT CHECK METHOD

TOWER:
INSPECTION DATE:
INSPECTORS:
TRANSIT TYPE AND NUMBER:
WIND DIRECTION AND SPEED:

NOTE: Positive (+) sign convention indicates deflection to the right, negative (-) indicates deflection to the left.

LEVEL AT WHICH READINGS WERE TAKEN	LEG A						LEG B						LEG C					
	TRANSIT @ T1			TRANSIT @T2			TRANSIT @ T1			TRANSIT @T2			TRANSIT @ T1			TRANSIT @T2		
	SCOPE NORMAL (INCHES)	SCOPE INVERSE (INCHES)	SCOPE AVG. (INCHES)	SCOPE NORM. (INCHES)	SCOPE INV. (INCHES)	SCOPE AVG. (INCHES)	SCOPE NORM. (INCHES)	SCOPE INV. (INCHES)	SCOPE AVG. (INCHES)	SCOPE NORM. (INCHES)	SCOPE INV. (INCHES)	SCOPE AVG. (INCHES)	SCOPE NORM. (INCHES)	SCOPE INV. (INCHES)	SCOPE AVG. (INCHES)	SCOPE NORM. (INCHES)	SCOPE INV. (INCHES)	SCOPE AVG. (INCHES)
BASE																		
TOP																		

ALLOWABLE DEFLECTION BASED ON TOWER MANUAL, COMDTINST M11000.4, OR TOWER MANUFACTURER'S DOCUMENTATION

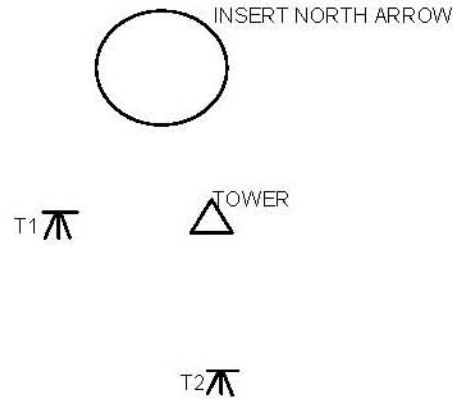

ALIGNMENT BY ONE-LEG METHOD

INSPECTION DATE:
INSPECTORS:
TRANSIT TYPE AND NUMBER:
WIND DIRECTION AND SPEED:

NOTE: Positive (+) sign convention indicates deflection to the right, negative (-) indicates deflection to the left.

GUY LEVEL	LEG DIAMETER (INCHES)	TRANSIT POSITION T1			TRANSIT POSITION T2			TRANSIT POSITION T3			ACTUAL DEFLECTION (IN.)		ALLOWABLE DEFLECTION* (IN.)	
		SCOPE NORMAL (INCHES)	SCOPE INVERSE (INCHES)	SCOPE AVG. (INCHES)	SCOPE NORMAL (INCHES)	SCOPE INVERSE (INCHES)	SCOPE AVG. (INCHES)	SCOPE NORMAL (INCHES)	SCOPE INVERSE (INCHES)	SCOPE AVG. (INCHES)	FROM CENTER	PREVIOUS LEVEL	FROM CENTER	PREVIOUS LEVEL

(* ALLOWABLE DEFLECTION BASED ON TOWER MANUAL, COMDTINST M11000.4, OR TOWER MANUFACTURER'S DOCUMENTATION.

GUY LEVEL	TOWER TWIST** (DEGREES)

(**) TWIST MEASURED OFF FACE A.

NOTE: THIS FORM SHOULD BE TAILORED TO THE SPECIFIC SYSTEM ON THE TOWER.

LIGHTING SYSTEM INSPECTION RECORD

DATE:
TOWER:
INSPECTOR:

MARK CONDITIONS AS
"GOOD", "FAIR" OR "POOR"

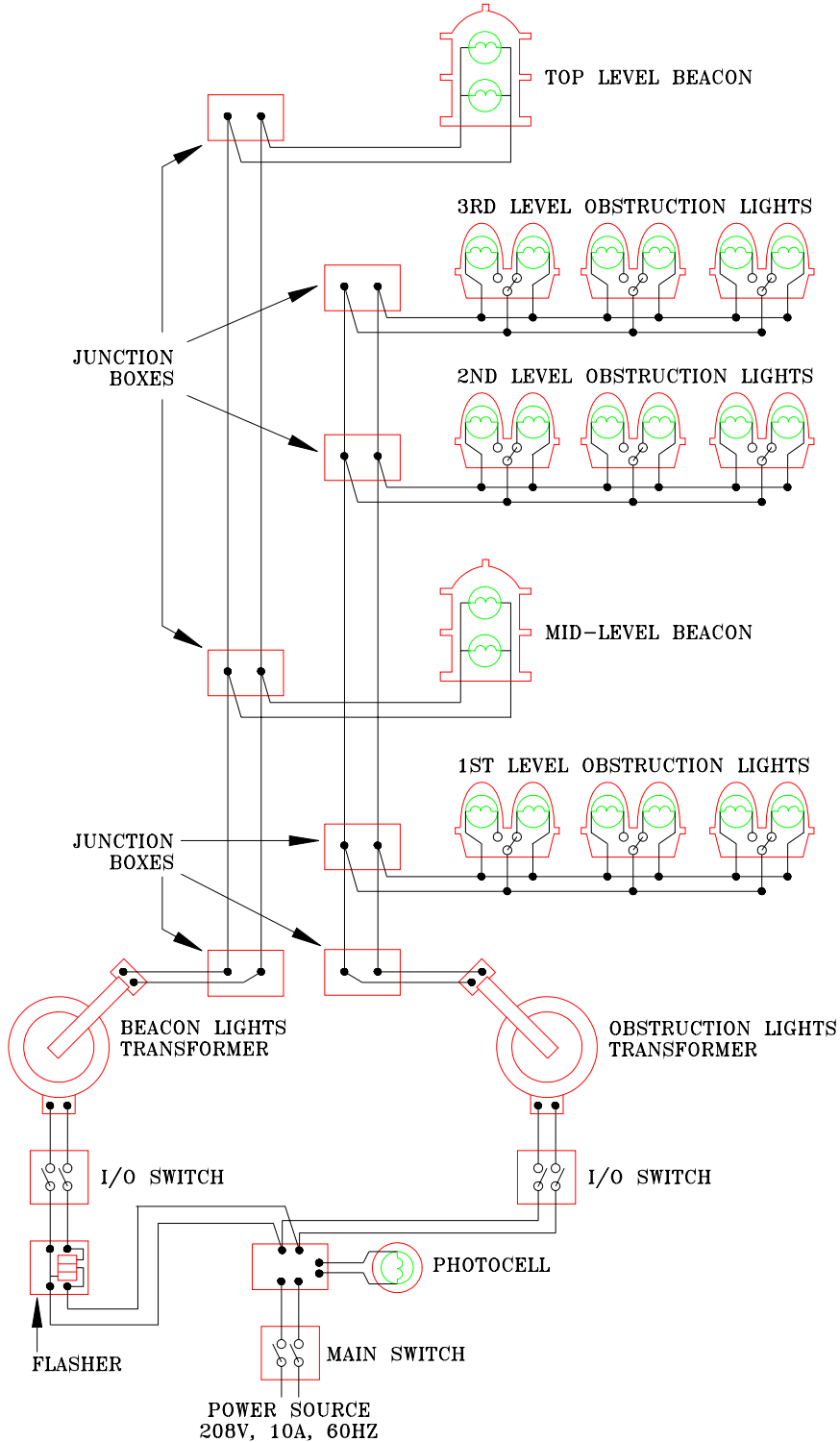

TOP LEVEL BEACON	
LAMPS CONDITION	
GASKETS CONDITION	
VOLTAGE READING (V)	
MEGGER READING (KΩ)	
JUNCT BOX CONDITION	

3RD LEVEL OBS LIGHTS	
LAMPS CONDITION	
RELAYS CONDITION	
GASKETS CONDITION	
VOLTAGE READING (V)	
MEGGER READING (KΩ)	
JUNCT BOX CONDITION	

2ND LEVEL OBS LIGHTS	
LAMPS CONDITION	
RELAYS CONDITION	
GASKETS CONDITION	
VOLTAGE READING (V)	
MEGGER READING (KΩ)	
JUNCT BOX CONDITION	

MID-LEVEL BEACON	
LAMPS CONDITION	
GASKETS CONDITION	
VOLTAGE READING (V)	
MEGGER READING (KΩ)	
JUNCT BOX CONDITION	

1ST LEVEL OBS LIGHTS	
LAMPS CONDITION	
RELAYS CONDITION	
GASKETS CONDITION	
VOLTAGE READING (V)	
MEGGER READING (KΩ)	
JUNCT BOX CONDITION	

BEACONS TRANSFORMER	
COATING CONDITION	
VOLTAGE READING (V)	
MEGGER READING (KΩ)	
JUNCT BOX CONDITION	

OBS LIGHTS TRANSFORMER	
COATING CONDITION	
VOLTAGE READING (V)	
MEGGER READING (KΩ)	
JUNCT BOX CONDITION	

MISCELLANEOUS	
SWITCHES CONDITION	
FLASHER CONDITION	
PHOTOCELL CONDITION	

TOWER ALIGNMENT BY ONE-LEG METHOD

DATE: _____ TOWER IDENTIFICATION: _____

INSPECTORS: _____

LEVEL/ELEVATION: _____ (USE DIFFERENT SHEET FOR EACH ELEVATION)

WIND: DIRECTION: _____ SPEED: _____

LEG DIAMETER: _____

TRUE BEARING FROM POSITION "T1" TO TOWER: _____

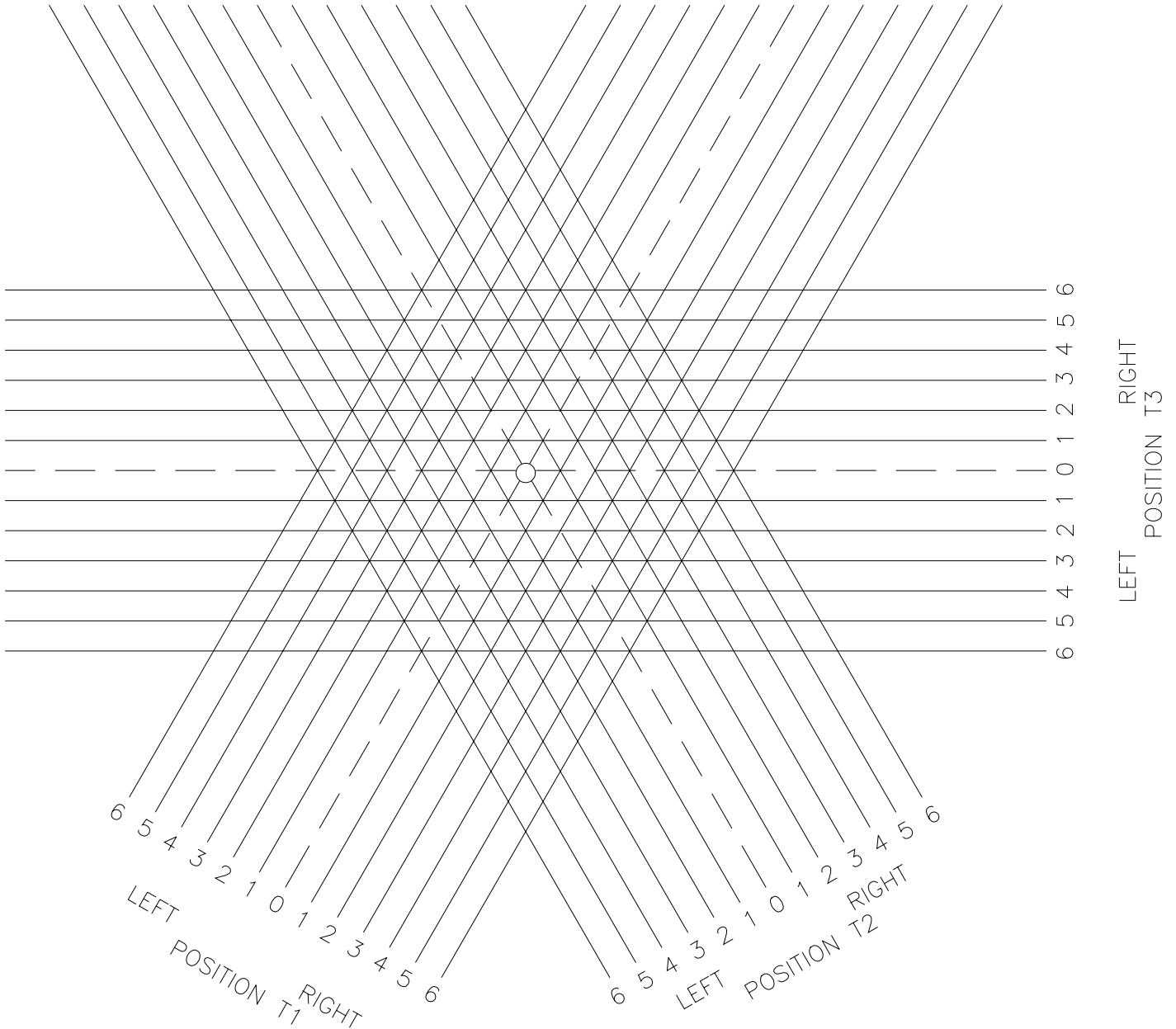

APPENDIX C. MANUFACTURER'S DATA FOR VARIOUS TOWER COMPONENTS

- A. Ordering Wire Rope or Strand. When ordering wire rope or strand always specify:
1. Length, diameter, construction, and number of strands.
 2. For wire rope, number of wires per strand.
 3. Arrangement of wires in each strand (left/right hand lay).
 4. Breaking strength and modulus of elasticity.
 5. Grade ("Bridge Strand", "EHS", "Utilities", etc.)
 6. Class of galvanized coating (A, B, or C), either on all wires or the required combination of coatings.
- B. Ordering Preformed Big-Grips or Splices. When ordering preformed products, specify:
1. Type and size of strand or rope on which to be used.
 2. Left/right hand lay.
 3. Class of galvanized coating, or, if Alumoweld, with conductive grit.
 4. Structural application.
 5. For use with johnny-ball type insulators; type, part number, and size of the insulator.
- C. Ordering Insulators. When ordering insulators of the johnny-ball type, specify:
1. Type (open/closed end).
 2. Mechanical strength.
 3. Wet and dry peak flashover rating.
 4. Size of cable in which insulators are to be used.
- D. Physical Properties of Various Tower Components. The following pages provide tables of physical properties which are for information only. When ordering materials, the current manufacturer's catalog should be consulted.

GALVANIZED BRIDGE STRAND CLASS A COATING

Strand Diameter Inches	Standard Construction	Breaking Strength in Tons	Approximate Weight Per Foot (in lbs.)	Approximate Metallic Area in Square Inches
1/2	1x19	15	0.52	0.15
9/16	1x19	19	0.66	0.19
5/8	1x19	24	0.82	0.23
11/16	1x19	29	0.99	0.28
3/4	1x19	34	1.18	0.34
13/16	1x19	40	1.39	0.40
7/8	1x19	46	1.61	0.46
15/16	1x19	54	1.85	0.53
1	1x19	61	2.10	0.60
1-1/16	1x43	69	2.37	0.68
1-1/8	1x43	78	2.66	0.76
1-3/16	1x43	86	2.96	0.85
1-1/4	1x43	96	3.28	0.94
1-5/16	1x43	106	3.62	1.03
1-3/8	1x43	116	3.97	1.13
1-7/16	1x43	126	4.34	1.24
1-1/2	1x43	138	4.73	1.35
1-9/16	1x67	150	5.13	1.47
1-5/8	1x67	162	5.55	1.59
1-11/16	1x67	176	5.98	1.71
1-3/4	1x67	188	6.43	1.84
1-13/16	1x67	202	6.90	1.97
1-7/8	1x67	216	7.39	2.11
1-15/16	1x67	230	7.89	2.25
2	1x97	245	8.40	2.40
2-1/16	1x97	261	8.94	2.55
2-1/8	1x97	277	9.49	2.71
2-3/16	1x97	293	10.05	2.87
2-1/4	1x97	310	10.64	3.04
2-5/16	1x97	327	11.24	3.21
2-3/8	1x133	344	11.85	3.38
2-7/16	1x133	360	12.48	3.57
2-1/2	1x133	376	13.13	3.75
2-9/16	1x133	392	13.80	3.94
2-5/8	1x133	417	14.47	4.13
2-11/16	1x161	432	15.20	4.33
2-3/4	1x175	452	15.88	4.54
2-7/8	1x175	494	17.36	4.96
3	1x175	538	18.90	5.40
3-1/8	1x175	584	20.51	5.86
3-1/4	1x223	625	22.18	6.34
3-3/8	1x223	673	23.92	6.83
3-1/2	1x223	724	25.73	7.35
3-5/8	1x223	768	27.60	7.88

GALVANIZED BRIDGE ROPE CLASS A COATING

Rope Diameter Inches	Standard Construction	Breaking Strength in Tons	Approx. Wt. Per Foot (In Pounds)
5/8	6x7 w/ strand core	18	0.65
3/4	6x7 w/ strand core	26	0.95
7/8	6x7 w/ strand core	35	1.28
1	6x7 w/ strand core	45.7	1.67
1-1/8	6x7 w/ strand core	57.8	2.11
1-1/4	6x7 w/ I. W. R. C.	72.2	2.64
1-3/8	6x7 w/ I. W. R. C.	87.8	3.21
1-1/2	6x7 w/ I. W. R. C.	104	3.82
1-5/8	6x25 Filler Wire	123	4.51
1-3/4	6x25 Filler Wire	143	5.24
1-7/8	6x25 Filler Wire	164	6.03
2	6x25 Filler Wire	186	6.85
2-1/8	6x25 Filler Wire	210	7.73
2-1/4	6x25 Filler Wire	235	8.66
2-3/8	6x25 Filler Wire	261	9.61
2-1/2	6x25 Filler Wire	288	10.60
2-5/8	6x25 Filler Wire	317	11.62
2-3/4	6x25 Filler Wire	347	12.74
2-7/8	6x43 Filler Wire	379	13.90
3	6x43 Filler Wire	412	15.11
3-1/4	6x43 Filler Wire	475	18.00
3-1/2	6x43 Filler Wire	555	21.00
3-3/4	6x43 Filler Wire	640	24.00
4	6x43 Filler Wire	730	27.00

GALVANIZED WIRE STRAND CLASS "A", "B", AND "C" COATINGS

Nominal Diam of Strand (in.)	Number of Wires in Strand	Nominal Diam of Coated wires in strand (in.)	Weight of Strand per 1000ft. (lbs)	Minimum Breaking Strength of Strand (lb)				
				Utilities Grade	Common Grade	Siemens- Martin Grade	High Strength Grade	Extra High Strength Grade
3/16	7	0.062	72.9	-	1150	1900	2850	3990
3/16	7	0.065	80.3	2400	-	-	-	-
7/32	7	0.072	98.3	-	1540	2560	3850	5400
1/4	3	0.120	116.7	3150	-	-	-	-
1/4	3	0.120	116.7	4500	-	-	-	-
1/4	7	0.080	121.0	-	1900	3150	4750	6650
9/32	7	0.093	164.0	4600	2570	4250	6400	8950
5/16	3	0.145	170.6	6500	-	-	-	-
5/16	7	0.104	205.0	-	3200	5350	8000	11200
5/16	7	0.109	225.0	600	-	-	-	-
3/8	3	0.165	220.3	8500	-	-	-	-
3/8	7	0.120	273.0	11500	4250	6950	10800	15400
7/16	7	0.145	399.0	18000	5700	9350	14500	20800
1/2	7	0.165	517.0	25000	7400	12100	18800	26900
1/2	19	0.100	504.0	-	7620	12700	19100	26700
9/16	7	0.188	671.0	-	9600	15700	24500	35000
9/16	19	0.133	637.0	-	9640	16100	24100	33700
5/8	19	0.125	796.0	-	11000	18100	28100	40200
3/4	19	0.150	1155.0	-	16000	26200	40800	58300
7/8	19	0.177	1581.0	-	21900	35900	55800	79700
1	19	0.200	2073.0	-	28700	47000	73200	104500

ALUMINUM COATED STEEL CABLE

No. and size of wires	Nominal Diameter (In)	Breaking Load (lbs)	Weight per 1000ft (lbs)
37 No. 5 AWG	1.27	142800	2802.0
37 No. 6 AWG	1.13	120200	2222.0
37 No. 7 AWG	1.01	100700	1762.0
37 No. 8 AWG	0.899	84200	1398.0
37 No. 9 AWG	0.801	66700	1108.0
37 No. 10 AWG	0.713	52950	879.0
19 No. 5 AWG	0.910	73350	1430.0
19 No. 6 AWG	0.810	61700	1134.0
19 No. 7 AWG	0.721	51730	899.5
19 No. 8 AWG	0.642	43240	713.5
19 No. 9 AWG	0.572	34290	565.8
19 No. 10 AWG	0.509	27190	448.7
7 No. 5 AWG	0.546	27030	524.9
7 No. 6 AWG	0.486	22730	416.3
7 No. 7 AWG	0.433	19060	330.0
7 No. 8 AWG	0.385	15930	261.8
7 No. 9 AWG	0.343	12630	207.6
7 No. 10 AWG	0.306	10020	164.7
7 No. 11 AWG	0.272	7945	130.6
7 No. 12 AWG	0.242	6301	103.6
3 No. 5 AWG	0.392	12230	224.5
3 No. 6 AWG	0.349	10280	178.1
3 No. 7 AWG	0.311	8621	141.2
3 No. 8 AWG	0.277	7206	112.0
3 No. 9 AWG	0.247	5715	88.8
3 No. 10 AWG	0.220	4532	70.4

ALUMINUM COATED STEEL CABLE ("M STRAND")

Designation	Nominal Diameter of Strand (In.)	No. and Diameter of Individual Wires	Breaking Load (lbs)	Weight per 1000ft (lbs)
4M - AW 3	0.220	3 x .102"	4000	70
6M - AW 7	0.242	7 x .081"	6000	104
8M - AW 7	0.272	7 x .091"	8000	131
10M - AW 7	0.306	7 x .102"	10000	165
12.5M - AW 7	0.343	7 x .114"	12500	208
14M - AW 7	0.363	7 x .121"	14000	232
16M - AW 7	0.386	7 x .128"	16000	262
18M - AW 7	0.417	7 x .139"	18000	306
20M - AW 7	0.444	7 x .148"	20000	347
25M - AW 7	0.519	7 x .173"	25000	475

COPPER COATED STEEL CABLE

COPPER COATED STEEL CABLE

No. and size of wires	Nominal Diameter (In)	Breaking Strength (lbs)			Weight per 1000ft (lbs)
		High Strength 40% Cond.	High Strength 30% Cond.	Extra High Strength 30% Cond.	
37 No. 5 AWG	1.27	97830	108200	130300	3466.0
37 No. 6 AWG	1.13	81020	98250	108100	2749.0
37 No. 7 AWG	1.01	66970	73500	89290	2180.0
37 No. 8 AWG	0.899	55270	60450	73400	1729.0
37 No. 9 AWG	0.801	45540	49650	59920	1371.0
37 No. 10 AWG	0.713	37640	41000	48610	1087.0
19 No. 5 AWG	0.910	50240	55570	66910	1770.0
19 No. 6 AWG	0.810	41600	45830	55530	1403.0
19 No. 7 AWG	0.721	34390	37740	45850	1113.0
19 No. 8 AWG	0.642	28380	31040	37690	882.7
19 No. 9 AWG	0.572	23390	25500	30610	700.0
7 No. 4 AWG	0.613	22310	24780	19430	818.9
7 No. 5 AWG	0.546	18510	20470	24470	649.4
7 No. 6 AWG	0.486	15330	16890	20460	515.0
7 No. 7 AWG	0.433	12670	13910	16890	408.4
7 No. 8 AWG	0.385	10460	11440	13890	323.9
7 No. 9 AWG	0.343	8616	9393	11280	256.9
7 No. 10 AWG	0.306	7121	7758	9196	203.7
3 No. 5 AWG	0.392	8373	9262	11860	277.8
3 No. 6 AWG	0.349	6934	7639	9754	220.3
3 No. 7 AWG	0.311	5732	6291	7922	174.7
3 No. 8 AWG	0.277	4730	5174	6282	138.5
3 No. 9 AWG	0.247	3898	4250	5129	109.9
3 No. 10 AWG	0.220	3221	3509	4160	87.1
3 No. 12 AWG	0.174	2236		2565	54.8

COPPER COATED STEEL CABLE ("M" STRAND)

Designation	Nominal Diameter of Strand (In)	No. and Diameter of Individual Wires	Breaking Load (lbs)	Weight per 1000ft (lbs)
2.2M	0.157	3 x .073"	2200	45
4M	0.209	3 x .097"	4000	79
6M3	0.258	3 x .120"	6000	121
6M	0.237	7 x .079"	6000	122
8M	0.276	7 x .092"	8000	166
10M	0.303	7 x .101"	10000	200
12.5M	0.345	7 x .115"	12500	259
14M	0.360	7 x .120"	14000	283
16M	0.386	7 x .128"	16000	324
18M	0.414	7 x .138"	18000	374
20M	0.432	7 x .144"	20000	407

Note: BIG-GRIP is a registered trademark of Preformed Line Products Company. All data referenced herein concerning BIG-GRIP dead ends is copyrighted and is used in this Manual with express written permission of the manufacturer.

BIG-GRIP dead-end

C-COAT GALVANIZED STEEL

SPECIAL INDUSTRY TOWER AND ANTENNA USE for use on: Galvanized Steel Strand

Catalog Number	Strand			Length (in)	Color Code
	Size	Construction	Mean Diameter		
BG-2140	1/8"	7W	.123"	14	Blue
BG-2142	3/16"	7W	.186"	23	Red
BG-2144	1/4"	3W	.259"	27	Yellow
		7W	.240"		
BG-2145	9/32"	7W	.279"	30	Blue
BG-2146	5/16"	3W	.312"	33	Black
		7W	.312"		
BG-2147	3/8"	3W	.356"	37	Orange
		7W	(.360")		
BG-2148	7/16"	7W	.435"	40	Green
BG-2115	1/2"	7W	.495"	50	Blue
		19W	.500"		
BG-2116	9/16"	7W	.564"	55	Yellow
		19W	.565"		
BG-2111	5/8"	7W	.621"	64	Black
		19W	.625"		
BG-2112	3/4"	19W	.750"	76	Orange

Left Hand Lay Standard

NOMENCLATURE

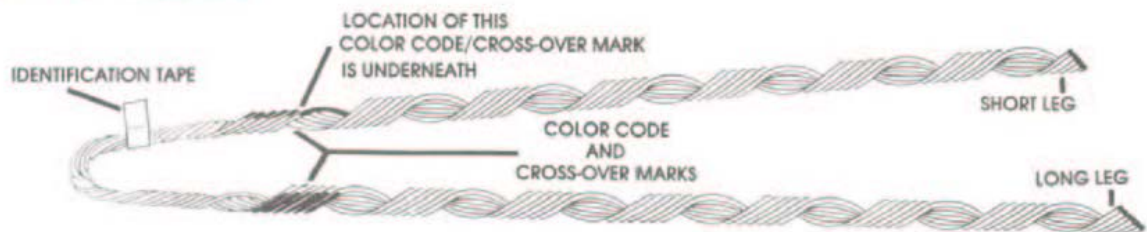

BIG-GRIP dead-end ALUMOWELD

SPECIAL INDUSTRY TOWER AND ANTENNA USE for use on: Alumoweld Strand

Catalog Number	Mean Diameter (In)	Nominal Strand Size	Length (in)	Color Code
BG-4204	0.174	3 #12	19	Orange
BG-4208	0.220	4M	22	Green
	0.220	3 #10		
BG-4210	0.247	3 #9	24	Yellow
	0.242	6M		
BG-4213	0.277	3 #8	27	Blue
	0.272	8M		
BG-4216	0.311	3 #7	29	Black
	0.306	10M		
	0.306	5/16" 7 #10		
BG-4220	0.349	3 #6	32	Yellow
	0.343	12.5M		
	0.343	11/32" 7 #9		
BG-4221	0.363	14M	35	Blue
BG-4223	0.392	3 #5	36	Orange
	0.385	3/8" 7 #8		
	0.386	16M		
BG-4225	0.417	18M	39	Black
BG-4226	0.433	7/16" 7 #7	40	Green
BG-4227	0.444	20M	41	Yellow
BG-4168	0.486	1/2" 7 #6	42	Blue
BG-4169	0.509	19 #10	44	Green
BG-4170	0.519	25M	47	Red
BG-4171	0.546	7 #5	48	Yellow

Left Hand Lay Standard

BIG-GRIP dead-end GALVANIZED STRAND

For Use On:

Extra High Strength

Siemens Martin

High Strength

Utilities Grade

Catalog Number	Strand		Actual Diameter (in)	Approx. Length (In)	Color Code	Rated Holding Strength (lbs)	Percent of Strand's Rated Breaking Strength
	Size	Construction					
BG-2115	1/2"	7W or 19W	0.459 or 0.500	49	Blue	26,900	(100%)
BG-2116	9/16"	7W or 19W	0.564 or 0.565	55	Yellow	35,000	(100%)
BG-2111	5/8"	7W or 19W	0.621 or 0.625	64	Black	7W 42,400 19W 40,200	(100%) (100%)
BG-2112	3/4"	19W	0.750	76	Orange	58,300	(100%)
BG-MS-7023	7/8"	19W	0.885	90	Green	79,700	(100%)
BG-MS-7047	1	19W or 37W	1.000 or 1.001	125	Blue	19W 104,500 37W 92,430	(100%) (90%)

Left-hand Lay Standard

Big-Grip dead-end for use on: Aluminum Covered Steel Strand

Catalog Number	Strand Diameter Range (in)		Nominal Strand Size	Approx. Length (In)	Color Code	Rated Holding Strength (lbs)	(Percent of Strand's Rated Breaking Strength)
	Min.	Max.					
BG-4168	0.475	0.494	7 #6	42	Blue	22730	(100%)
BG-4169	0.495	0.515	19 #10	44	Green	27190	(100%)
BG-4170	0.516	0.536	25M	47	red	25000	(100%)
BG-4171	0.537	0.555	7 #5	48	Yellow	27030	(100%)
BG-4172	0.556	0.570	-	49	Blue	33330	
BG-4173	0.571	0.591	19 #9	50	Orange	34290	(100%)
BG-4174	0.592	0.612	-	50	Green	34450	
BG-4175	0.613	0.635	-	54	Yellow	45000	
BG-4176	0.636	0.661	19 #8	56	Black	43240	(100%)
BG-4177	0.662	0.686	19x.1363"	59	Blue	47400	(100%)
BG-4178	0.687	0.712	-	61	Red	54200	
BG-4179	0.713	0.741	19 #7	63	Black	51730	(100%)
			37#10			50300	(95%)
BG-4180	0.742	0.772	19 x.1499"	71	Yellow	54300	(100%)

The following Products are for the Specific cables listed

	Actual Diameters					
BG-4181	0.792	19 x.1584"	80	Blue	59000	
BG-4183	.801, .810, .827	37 #9	84	Green	63430	(95%)
		19 #6 19 x.1660"			61700 63000	(100%) (100%)
BG-4185	.849, .850, .866	37 x.121"	87	Yellow Black	71250	(95%)
		19 x.170"			66000	(100%)
		19 x.173"			68500	(100%)
		37 x.123"			74100	(95%)
BG-4186	0.899	37 #8	91	Yellow	80000	(95%)
BG-4187	.910, .934	19 #5	93	Blue	73350	(100%)
		19x.1868"			75000	(100%)
BG-4188	0.981	37 x.1404"	95	Red	90250	(95%)
BG-4189	1.01	37 #7	108	Green	90600	(90%)
BG-4190	1.10	37 x.1571"	117	Black	101700	(90%)
BG-4191	1.13	37 #6	120	Yellow	108200	(90%)
BG-4192	1.27	37 #5	151	Red	127000	(89%)

Left-hand Lay Standard

1. BIG-GRIP dead-ends should be specified for all tower applications rather than GUY-GRIP.
2. BIG-GRIP dead-ends are precision devices. To insure a tight assembly, they should be handled carefully. To prevent distortion and damage, they should be installed as directed by the manufacturer.
3. BIG-GRIP dead-ends should be stored in cartons under cover until used.

4. BIG-GRIP dead-ends may be removed and re-applied two times, if necessary, on new construction, for the purpose of re-tensioning guys. BIG-GRIP dead-ends should not be re-used after original installation.
5. BIG-GRIP dead-ends should be used only on the size strand for which they are designed.
6. BIG-GRIP dead-ends should not be used as tools-- that is, come-alongs, pulling in grips, etc.
7. BIG-GRIP dead-ends should be applied only to smooth-contoured pole line hardware which has ample radius. Drive hooks, eye bolts and eye nuts do not have ample radius. If this type of fitting is desired, a heavy-duty cable thimble of proper size should be used. Strap-type hardware is not recommended.
8. BIG-GRIP dead-ends should not be used on hardware which allows the strand to rotate or spin about its axis uncontrolled. Adjustable hardware such as a turnbuckle, may be used as long as rotational movement of the strand is restricted.
9. BIG-GRIP dead-ends should be used with compatible strand and fittings.
10. When BIG-GRIP dead-ends are used on storm guys, the guys must be tensioned so to maintain a load at all times.
11. If in doubt about fittings or application, contact the manufacturer.

HARDWARE DIMENSIONS for GUY-GRIP dead-ends

Dead End Diameter Range	Nominal Strand Sizes	Seat Dimensions		Minimum Groove diameter	Minimum Hardware Hole Diameter	Heavy Duty Thimble Size	Pin Diameters		Double Extra Strong Weight Pipe		
		Min.	Max.				Min.	Max.	Nominal Size	O.D.	I.D.
.475-.515	1/2	1-3/8	2-3/8	9/16	3/4	5/8	1	1-5/8	1-1/4	1.66	0.896
.516-.570	9/16	1-1/2	2-5/8	5/8	15/16	5/8	1-1/8	1-5/8	1-1/4	1.66	0.896
.571-.635	5/8	2	2-5/8	3/4	1	3/4	1-1/2	1-7/8	1-1/4	1.66	0.896
.636-.772	3/4	2-1/2	3-1/8	7/8	1-3/16	7/8	1-7/8	2-1/8	1-1/2	1.9	1.1
.773-.868		2-1/2	3-5/8	1	1-3/8	1	2	2-3/8	2	2.375	1.503
.869-1.024	7/8	3	4-1/8	1	1-3/8	1-1/8 - 1-1/4	2-3/8	2-3/4	2	2.375	1.503
	1										
1.025-1.27		3-1/2	5-1/8	1-3/8	1-3/4	1-1/4 - 1-3/8	2-3/4	3-1/4	2-1/2	2.875	1.771
1.30		4	5-1/8	1-3/8	1-15/16	1-3/8 - 1-1/2	2-7/8	3-3/8	2-1/2	2.875	1.771

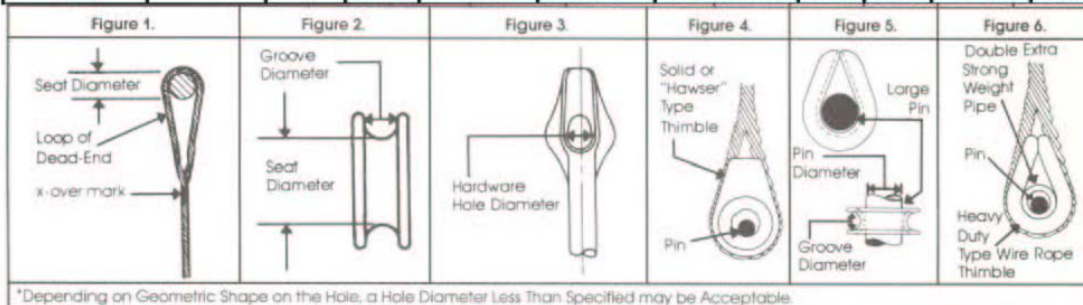

APPENDIX D. BASE INSULATOR REPLACEMENT

- A. General. Base insulators are very rarely replaced. Detailed procedures are not given in this Appendix because of the great variance in site conditions and tower sizes throughout the Coast Guard. The general guidance given is based primarily on experience gained during past base insulator replacements. Any plan to replace a base insulator should be closely coordinated with the Tall Tower Coordination Center.
- B. Planning.
1. If base insulator replacement is contemplated, conditions at the site must be accurately verified. Check: (1) orientation of the tower legs with respect to the foundation, (2) integrity and structural adequacy of the foundation, (3) severity of the damage (if any) to the existing insulator, (4) condition of the soil and elevation of the water table, and (5) condition and dimensions of the jacking pads on the tower.
 2. Consult the tower manufacturer's erection and maintenance manual and any related drawings.
 3. If acceptable to the contracting officer, meet with personnel (at the site, if possible) to simulate the replacement procedure before any work is accomplished. Primary emphasis should be on the safety of the structure and personnel, but minimization of off-air time should be next in importance. Actual field conditions should be carefully studied in the formulation of procedures.
 4. Locate the jacking frame and/or jacking legs that have been supplied with the tower or have been previously used for a base insulator change at the particular site. Loosely assemble the frame to determine its integrity and structural adequacy, and check for missing components. If a new frame is required, it may be made of components essentially the same as those of the tower structure. If any doubt exists, consult with the Tall Tower Coordination Center concerning sizes and types of materials or other questions related to the jacking frame. Some towers are built with a permanent jacking frame attached to the tower. In such cases, check to make sure that the jacking legs are available and that they are the proper size. See Figure D-1 for a picture of a jacking frame and jacking leg.
 5. Some tower foundations have pads for jacking built into an exposed footing. A decision on the method of providing support for the jacking frame must be made early in case an extended foundation is to be constructed or special grillage material is required. In some cases it may be possible to excavate to the top of the footing, but soil conditions may preclude this.
 6. Determine whether isolation transformers will have to be relocated during the insulator replacement, and make provisions accordingly. Replacement of the base insulator while the tower is energized is not authorized.



Figure D-1 Tower jacking legs installed on permanent jacking frame prior to insulator replacement.

C. General Description of Procedures. A single asterisk (*) indicates that some off-air time is usually required; particular attention to these procedures will minimize loss of service. A double asterisk (**) indicates that all or part of this step may not be required or feasible.

1. (*) (**) Fabricate and install a steel collar around the ceramic of the existing insulator. The collar should be sized to transmit the load of the tower from the top plate of the insulator to the bottom plate should the ceramic fail. A gap of 1 1/2-2 inches (38-51 mm) should be provided between the top of the collar and the top plate of the insulator in order to permit the tower to be energized. The collar is meant to help prevent a large drop of the tower should the insulator fail. If damage to the insulator is slight and can be monitored until replacement, this measure is unnecessary. This step is usually not necessary.
2. (*) (**) Install restraining cables (with strain insulators) from the area of the tower base platform to the inner structural anchors. These provide some extra lateral stability while the tower is jacked, but great care must be taken to ensure that the horizontal components of tension in the cables are equal.
3. Test the jacks and hydraulic system for integrity by jacking against two immovable objects (see Figure D-2). The jacking system may also be tested for sensitivity of control over the rate of descent, such as is shown in Figure D-3.
4. If feasible, Statiflux the replacement insulator (see Appendix E).
5. Measure and plot tower alignment and twist. Measure and record all guy tensions.
6. (*) Attach jacking frame and/or jacking legs to the tower, or install it in place beneath the tower. The frame may be designed to rest on the foundation

with jacks at the upper end (Figure D-4); it is more common for the frame to attach to the tower so that jacks are at foundation level (Figures D-1 and D-5). If the jacks are not in place and the area is carefully cleared, the tower may be re-energized.

7. (*) Accurately measure all lightning ball gaps for future resetting.
8. (**) Cut off the threaded extensions of all insulator base plate hold-down bolts just above the nut tops. This will minimize the distance the tower must be lifted. This step does not apply to newer towers where the bolts may be removed.
9. (**) Slacken structural guys. This is required only on certain towers and should be accomplished only if specifically advised by the Tall Tower Coordination Center.
10. Man two transits positioned 90° apart within fifty feet of the tower. These transit men should continuously monitor the tower position during jacking. Fixed sighting devices may be used instead of transits.
11. Remove the base insulator hold-down nuts. On newer towers the bolts may be removed, and should be done in conjunction with step 15. below.
12. (*) (**) Remove the RF feedline. Remove or adjust lighting transformers, and lightning ball gaps. If the transformers or ball gaps are not removed from the tower, they will likely need to be adjusted so that they are not damaged as the tower is raised and lowered.



Figure D-2 Testing of hydraulic jacking system by placing jacks in series between two immovable objects.



Figure D-3 Testing of rate of descent of a jack by loading it with a metered heavy beam.



Figure D-4 Jacking Frame utilizing jack at the upper end. Note restraining guys that are visible at the top of the photo.



Figure D-5 Jacks, shims, jacking legs, and jacking frame supporting tower after insulator has been removed. Notice shim plates between jack and jacking legs to prevent tower from falling if the jacks fail. Also note that the ball gaps and lighting transformers have been left on the tower but have been adjusted a number of times to provide clearance as the tower was raised.

13. (*) (**) Install tie rods in the base insulator. This step is required only on the newer insulators. See Figure D-6.
14. (*) Install jacks, shims as necessary (see Figure D-7), and pumping rig. Ensure that some kind of positive mechanical apparatus is incorporated into the jacking system to prevent sudden settling of the tower if a hydraulic leak occurs. For example, steel collars may be fabricated to fit around the extended jack rams (see 16. below), or safety-type jacks may be used. Hydraulic jacks should be connected to a common manifold to ensure an even distribution of pressure. (See Figure D-8) However, with adequate control over both men and equipment, separately controlled jacks have been satisfactorily used.
15. (*) Jack the tower slightly and rock the base insulator with crowbar to check for horizontal bearing on the center pin. Remove base insulator hold-down bolts where possible.
16. (*) Jack the tower to the full height required. This is normally the height of the center pin plus the height of the hold-down bolts plus about 1/2-inch (See Figure D-9). As the tower is raised, insert slotted shim plates between the tower base and the top of the base insulator so that the amount of drop is minimized in the event of a jack failure. The "slot" should be sized to fit around the center pin. Slotted shim plates may also be placed around the ram portion of the jacks to minimize the amount of drop in the event of a jack failure (See Figure D-7).
17. (*) (**) Unless safety type jacks are used, install collars around the jack rams when the tower is fully raised. Carefully monitor the jacks for settlement or shifting.

18. (*) Replace the base insulator. See Figure D-5 and Figure D-10.
19. (*) Loosely apply hold-down nuts. Remove the ram collars and lower the tower onto the new insulator. Utilize the slotted shim plates between the tower and insulator or the shim plates around the jack rams (as in 16. above), removing them gradually as the tower is lowered. Before loading the insulator, remove vent plugs.
20. (*) When the weight of the tower is on the new insulator, remove the tie rods if installed. Tighten hold-down nuts.
21. (*) (**) Re-install the RF feedline. Re-install or re-adjust the lighting transformers and lightning ball gaps. Install rain shield.
22. (*) Statiflux the new insulator (see Appendix E).
23. (*) Remove the jacks, clear the area, remove all connectors and equipment bridging the tower to the ground, and re-energize the antenna.
24. (*) After one full day, statiflux the base insulator. Cover the insulator with a protective collar, and remove the jacking frame if required. Establish proper oil levels, and check for leaks or other abnormalities.
25. (**) Re-tension structural guys if originally slackened.

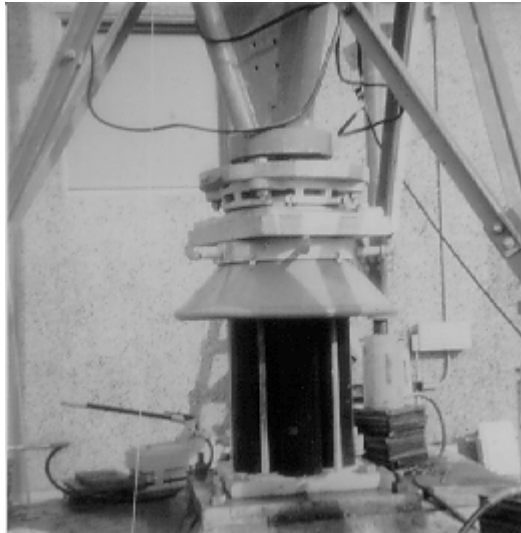

Figure D-6 New insulator in place, with spherical bearing assembly. Note the tie rods in the insulator, which must be kept installed until the weight of the tower is on the insulator. Shims, jack, and pump are in the background.



Figure D-7 Shims between jack and tower jacking leg.



Figure D-8 Hydraulic manifold attached to jacking frame for easy monitoring and security of the lines. Note jacks in place at the top of the jacking frame. A steel collar is attached around the base insulator.



Figure D-9 Tower jacked up to approximately 1/2-inch above center pin of base insulator.



Figure D-10 Removing the bolts that hold down the base insulator. It should be noted that once the tower's weight is removed from the insulator, oil may begin to leak out from under the ceramic portion of the insulator.

APPENDIX E. Special Evolutions for Loran-C Antenna Towers

- A. General. This appendix addresses those inspection, maintenance, repair and special evolutions required periodically over the life of a Loran-C antenna tower. The procedures outlined are considered adequate for the evolutions described, but variations suggested by experienced riggers should be considered as long as basic safety guidelines are met. These procedures should be followed whenever practical and possible. While an attempt should be made to always minimize off-air time, opportunities for inspection or maintenance presented through off-air time created for any valid reason should be utilized to the maximum extent.
- B. Loran-C Electric Energy and Hazards. With the exception of SLT and TIP type LORAN antennas, the Loran-C transmitter directly energizes the entire tower structure above the base insulator including the top loading elements. Very large voltage differences exist between these components and ground or metallic devices within the Radio Frequency (RF) field. The structural guys are insulated from the direct Loran-C energy at the points of their connection to the tower, but they nevertheless become energized by the RF field and through triboelectric effects caused by wind, snow, etc. If the breakup insulators are functioning properly (i.e., they are not short-circuited or arcing) there are larger voltages across them. Although all components of the tower structure, including the ladder and safety rail, carry a share of the RF current, personnel are safe from RF related shock hazards if all portions of their bodies are within the framework of the tower. However, any person who extends any portion of his body outside the tower framework, or is working on the ground in the vicinity of a guy, anchor, or conductive cable or rigging, is subject to varying degrees of RF shock. These shocks usually take the form of annoying tingles, but there is the possibility of a hazardous secondary effect through the sudden release of one's grip on a tool or on a member by which he is supporting himself. Severe RF shocks are most likely when a person, on the antenna or on the ground, either bridges the potential between antenna and ground, or comes in contact with a top-loading element. Personnel on the ground should limit their time within the fenced area of the tower base to no more than 6 minutes during any one hour period.
- C. Basic Safety Guidelines. Procedures outlined in this appendix will provide for the safe execution of any evolution discussed, provided the following BASIC SAFETY GUIDELINES are complied with:
1. Any person positioned on the tower such that their body from the chest upwards will at any time be outside the framework of the tower shall wear conductive clothing (see Section V. for specifications). This guideline does not apply to persons in the process of boarding the tower, provided the transition from ground to tower is made in a single uninterrupted effort as described in Evolution #1.
 2. Whenever any evolution described in this appendix is to be accomplished, a safety observer shall be stationed near the tower base, but outside of the protective fence, such that he has as clear a view as possible of personnel working on the tower or handling items which are connected to the tower in any manner. The safety observer, preferably a senior electronics technician, shall have primary responsibility to detect circumstances or conditions which present an unusual RF shock hazard to personnel. The safety observer

should possess a means of rapid communication to a technician who is standing ready to de-energize the antenna upon the shortest possible notice. During Evolutions #3 and #4, a safety observer should be positioned on the tower near the level at which work is being performed.

3. A rigger suspended such that his body is totally outside the framework of the tower for work on a guy system shall not be lowered along the guy beyond an imaginary point on the guy which is approximately six feet (2m) from the highest breakup insulator in the direction of the tower. See Figure E-1.

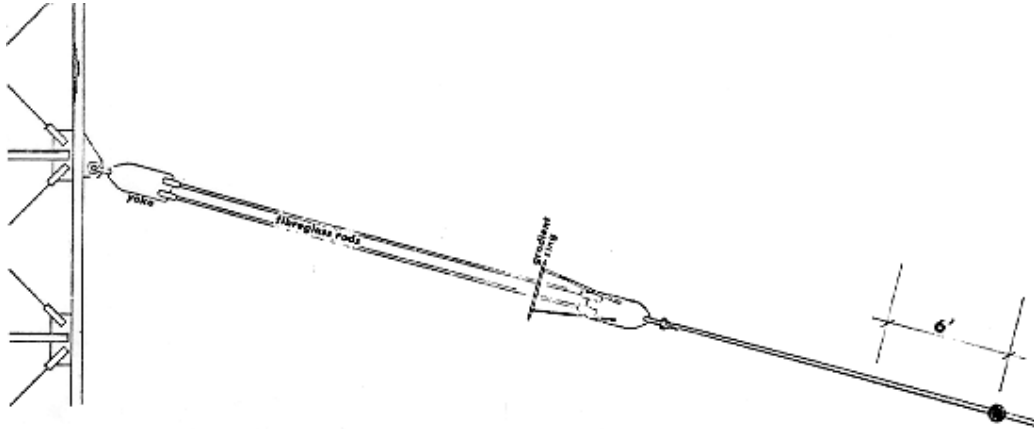

Figure E-1

4. All haul lines, tag lines, support lines, etc. leading to, from, or along the tower shall be "nonconductive". Positive actions shall be taken to ensure that these lines are kept dry, and stored under cover if unused for a period of time. Nonconductive line should be sized to provide a factor of safety of five based on the ratio of average breaking strength to working load. See paragraph E for specifications.
5. All persons inspecting or working on a portion of the guy system shall keep all portions of their bodies below the guy to the maximum extent possible.
6. Work involving rigging shall not be accomplished when the ground level wind speed exceeds 20 mph, except in emergency situations or where otherwise impractical. Work should be discontinued, and rigging secured, when electrical storm activity is present or forecast within the general geographical area.
7. Conductive items greater than about 3 feet (1m) in length, such as safety rail sections, which are being hoisted onto the tower shall be positioned so as to be well clear of any grounded object, and shall be electrically bonded to the tower structure before being handled by personnel on the tower. Once positioned totally within the tower framework, the bonding may be removed. The features of suitable bonding devices are described in paragraph E below.

- D. Evolutions Covered by this Appendix. Before a given evolution is attempted, it should be read in its entirety and a specific safety brief given to all personnel involved.

- #1 - Getting People on and off the Energized Tower
- #2 - Getting Things on and off the Energized Tower
- #3 - Working or Inspecting Outside the Tower Framework
- #4 - Replacing Structural Guy Insulator Rods
- #5 - Inspecting and Replacing TLE Insulator Rods and Gradient Rings
- #6 - Lowering a Structural Guy
- #7 - Lowering a Radial Guy
- #8 - Servicing Base Insulators and Isolation Transformers

EVOLUTION #1 - Getting People On and Off the Tower

1. General. Since the zero-to-peak voltage across the base insulator is in excess of 20 kV, the transition from ground potential to tower potential must be conducted with great care. Many years of experience by contractors and others have shown that towers can be safely mounted and dismounted using a non-conductive ladder or platform/ladder which has been kept thoroughly dry. The top of the mounting ladder should contain a small horizontal platform, to enable the person to bring as much of his body as close to the tower as possible before grabbing the tower structure.
2. Guidelines.
 - a. The transition from ladder to tower or vice versa should be made without hesitation.
 - b. The horizontal platform at the ladder top, if so equipped, is not a rest platform or a staging area, and should not be used as such.
 - c. The ladder should be stored inside in a dry area when not in use, and should be dry and clean when used.
3. Special Equipment.
 - a. 4:1 slope fiberglass ladder rated at a minimum of 200 kV, with top platform. (see Figure E-2) The ladder should be of pultruded structural fiberglass and in compliance with OSHA standards.
4. Procedure.
 - a. No off-air time is required for this evolution.

- b. Locate foot of ladder firmly on the ground, about 6 feet (2m) from the tower face.
- c. Holding rungs, lower top of ladder into the tower, so that it rests securely against the bottom rest platform.
- d. Climb ladder, holding rungs. While climbing, avoid touching any conductive object. At top platform, grasp rail and orient the body as near vertical as possible.
- e. With a sure deliberate motion, grasp the diagonal tower members with both hands. Avoid touching the tower legs.
- f. Enter the tower framework as rapidly as possible.
- g. When dismantling the tower, position the entire body outside of the tower framework and as close to the tower as possible. Ensure that climbing device, tool bags, etc. are free of the tower structure. If the tower must be dismantled in rainy or very damp conditions, especially if the access ladder has recently been wet, the tower must be de-energized.
- h. With sure, deliberate movements, grasp the fiberglass handrail and step onto the platform.
- i. Descend the ladder, holding the rungs. Avoid touching any conductive object.

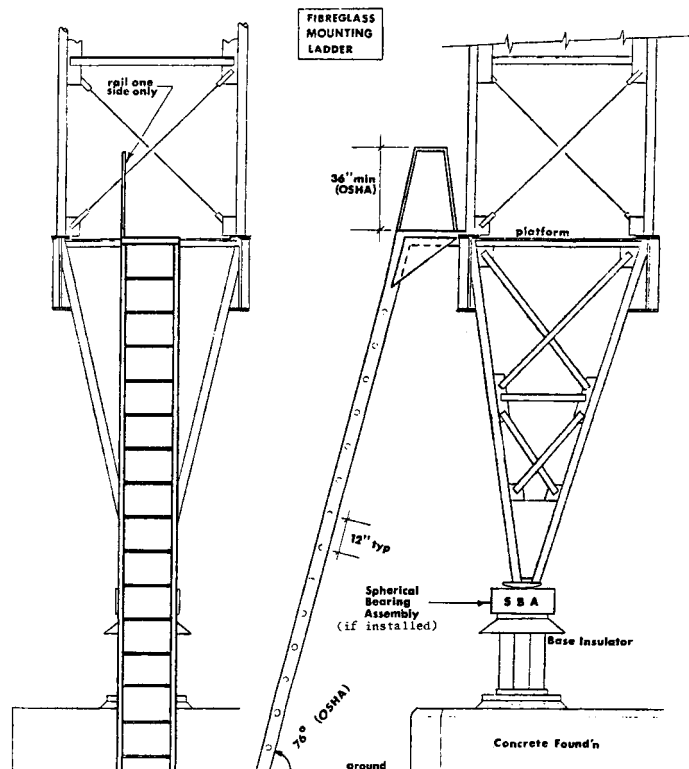

Figure E-2

EVOLUTION #2 - Getting Things On and Off the Tower

1. General. There are two basic categories of items which are needed on the tower: (1) the relatively small, such as paint cans, tools, backpacks, hotsticks, etc, which can be easily handled on the tower by one person; (2) the relatively large, such as spare insulator rods, heavy rigging apparatus, safety rail sections, etc. which must be hauled up by mechanical means. The former items should be hauled up a fiberglass slide similar to that shown in Figure 2. This will minimize the chance for damaging the base insulator, arcing through contact with an energized member, or transmitting a shock to a ground worker. The latter items are normally hauled up the outside face of the tower structure until they can be placed inside the tower framework, if possible. The most important consideration is that haul lines, not people, should be used to transport equipment from the ground to the tower and vice-versa.
2. Guidelines.
 - a. Materials should be kept clear of the base insulator and the isolation transformers. When passing long objects such as safety rail sections or insulator rods to or from the tower, personnel on the ground should not handle the lower end of these objects while the upper ends are near or in contact with the tower structure or an energized component.
 - b. A non-conductive tag line shall be used for items not conveniently raised by means of the fiberglass slide.
 - c. All haul lines shall be non-conductive.
 - d. The slide should be stored as per guidelines for the ladder (see Evolution # 1).
3. Special Equipment.
 - a. 30' (9m) length of 1/2 inch (12.7 mm) diameter non-conductive line, with large safety snap at each end.
 - b. Nonconductive haul and tag lines required.
 - c. Fiberglass slide as shown in Figure 2.
4. Procedure.
 - a. No off-air time is required for this evolution.
 - b. Stage materials near the tower base.
 - c. By Evolution #1, worker mounts the tower equipped with the 30' (9m) line. For raising of the relatively large category items, rig as necessary, keeping haul lines well away from the tower base as items are hauled.

- d. Snap one end of 30' (9m) line to a tower girt or diagonal. Pass the other end down the slide.
- e. Haul materials as required. The worker on the tower should remain within the tower framework to the maximum extent.
- f. Follow basic guidelines and good judgement in unusual cases.

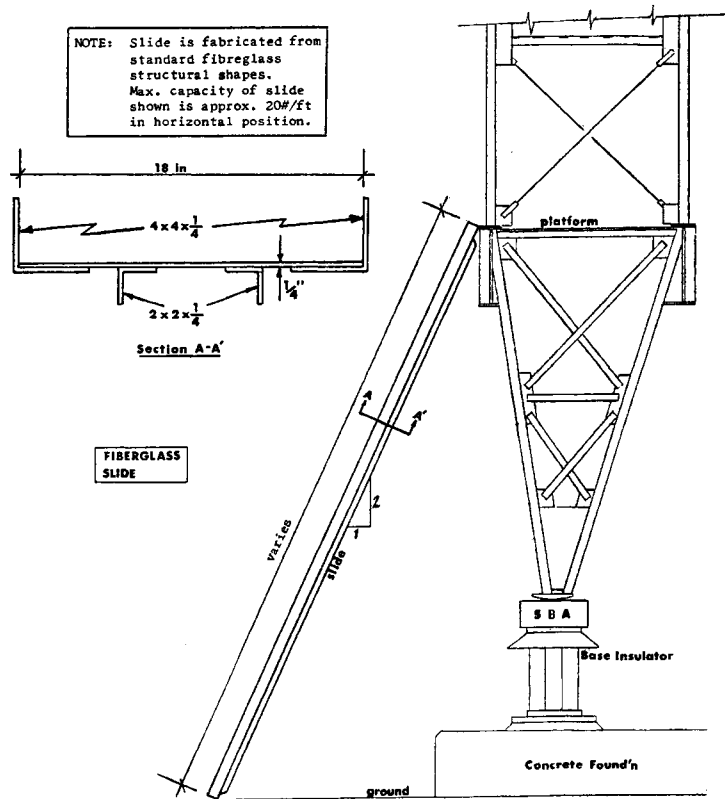

Figure E-3

EVOLUTION #3 - Working or Inspecting Outside the Tower Framework

1. General. It has been determined through experience that the effect of the electromagnetic field from a Loran-C tower on a worker may be effectively eliminated if the worker is wearing conductive clothing.

Note: This conductive clothing is not designed to protect personnel when two or more parts of the body are in contact with conductive members at different voltage levels.

The guidelines for this evolution are also based on the premise that the great majority of work or inspections performed outside the tower framework will be accomplished between the tower and the lower yoke of the strain insulator assemblies.

2. Guidelines.
 - a. See Basic Safety Guidelines above.

- b. No off-air time is required for this evolution.
- c. The worker should be seated in a boatswains' chair or similar apparatus, which is connected to a primary support line. Contractors may provide a chair or seat of their own design. Primary support lines should be connected to the tower at the next highest guy level or higher.
- d. A safety line connected directly to the worker should be used, connected approximately 40 feet (12m) above the working area.
- e. Workers shall transport themselves from the tower to the lower yoke plate, and return, by means of a fiberglass hot stick telescoping pole with suitable end hook attached. Under no circumstances may the worker be permitted to use the installed guy strain insulators to transport himself while the antenna is energized.
- f. All support lines should be non-conductive.

3. Special Equipment.

- a. Support lines as required.
- b. Conductive suit, socks, and gloves.
- c. Boatswain's chair or seat.
- d. Hot stick telescoping pole.

4. Procedure.

- a. If worker is to remain at the tower face only, and not inspect or maintain a lower portion of the guy system, use two standard 5ft safety lanyards to secure the worker to the tower. Do not use the bos'n chair and rigging shown in Figures 3A and 3C.
- b. Ensure a good bond between suit, socks, and gloves, utilizing the provisions incorporated in the conductive clothing. If worker is to remain in one place for a relatively long period of time, the bonding straps attached to the suit may be tied to tower members (or the guy if working on the guy system) by a simple half-knot to provide added Faraday-type protection. THESE ARE NOT SAFETY STRAPS.
- c. If the worker is to inspect or service components at or near a lower strain insulator yoke plate, rig the primary support line to the boatswain's chair, and the safety line to the worker (Figures 3A and 3B). The primary support line should be secured to the tower at least 80 feet above the level of the worker because of the effort required to move along the telescoping pole.
- d. Extend the hot stick telescoping pole and insert the hook through the eye of the PLP grip, the lower yoke shackle, or the large hole of the lower yoke plate (see Figure 3A). The long, flexible telescoping pole is best handled by two workers on the tower,

especially if there is a cross wind. Lash the tower end of the pole to a leg or girt for security. The worker may then transport himself from the tower to the lower yoke by pulling out along the hot stick telescoping pole; he must return to the tower in the same manner. The pole may be temporarily removed while the worker is at the lower yoke if it is obstructing the work.

- e. If worker is to remain at a particular portion of the guy system for a few minutes or longer, small, easily parted lines (rated at about 50 lbs breaking load) should be used to secure the boatswain chair to the guy. This is for steadying the worker, and not safety, so that in the unlikely event of a guy failure the worker is not carried along with the guy.

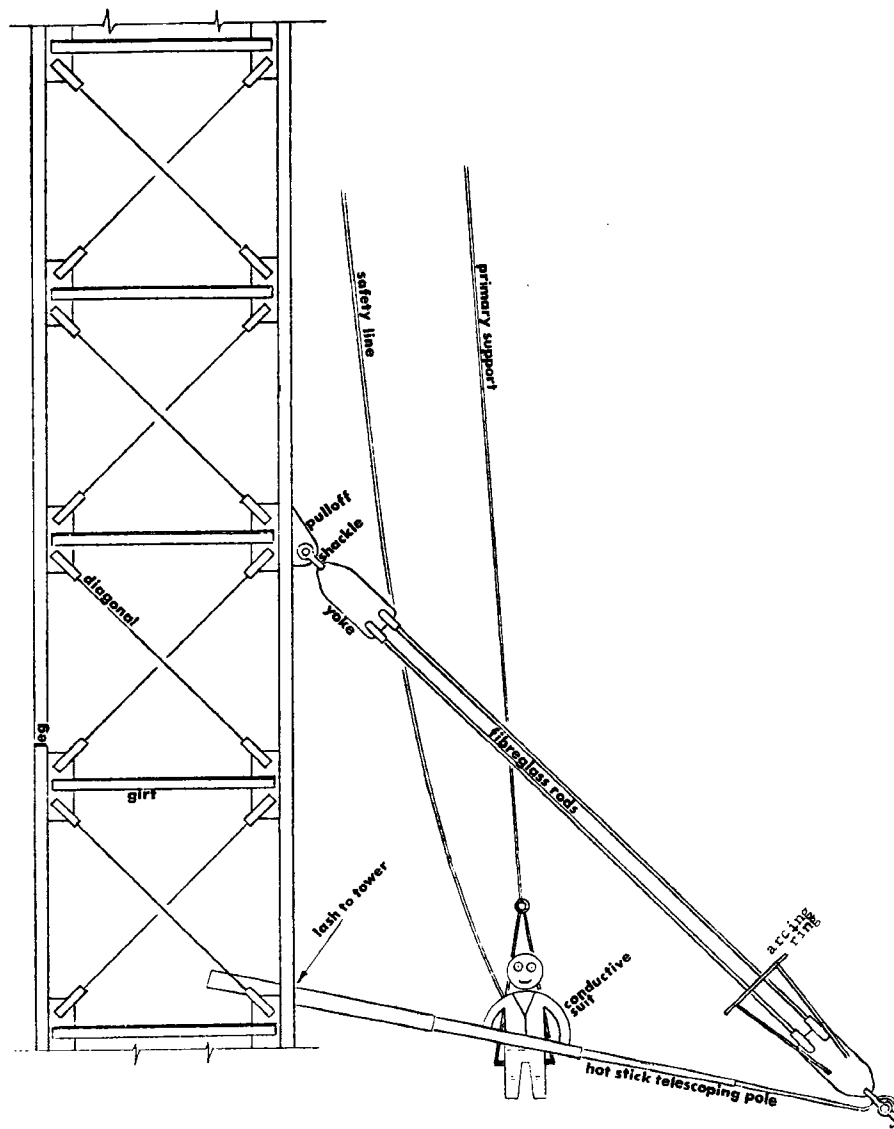

Figure E-4 Moving to and from Lower Yoke Plate.

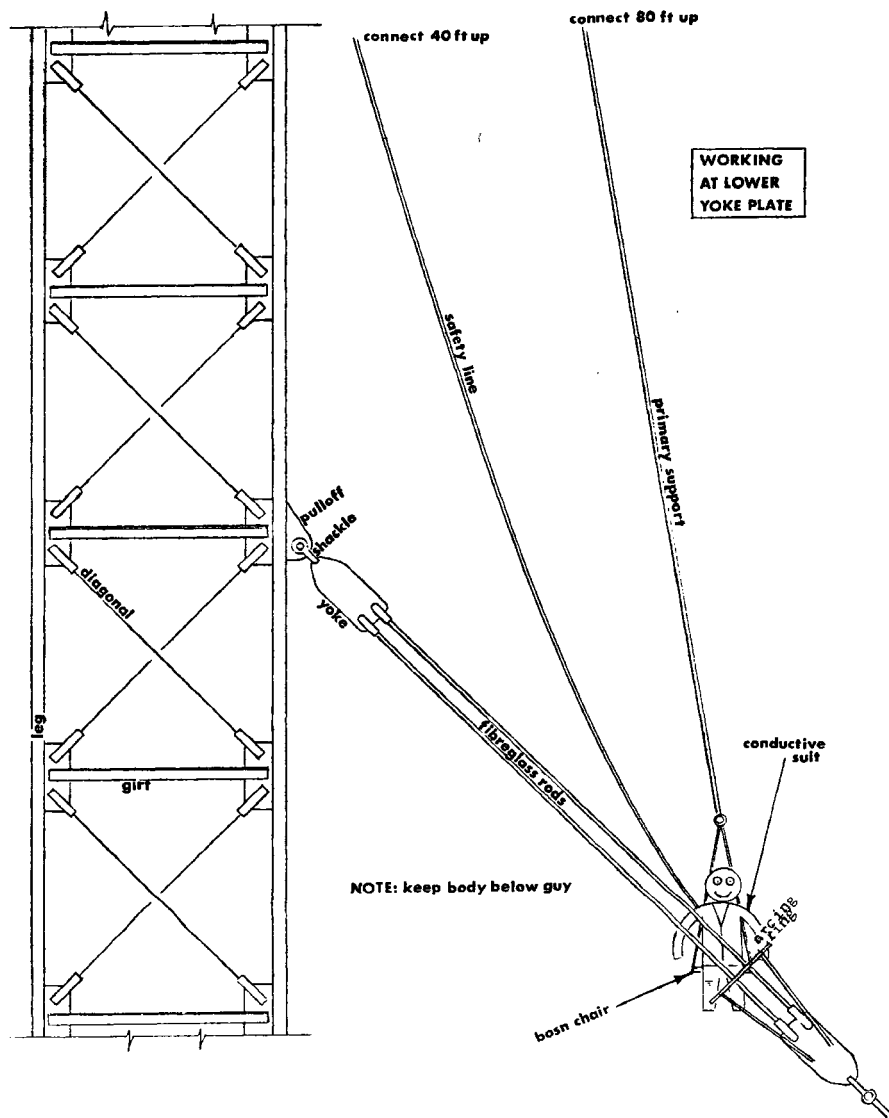

Figure E-5 Working at Lower Yoke Plate

EVOLUTION #4 - Replacing Structural Guy Insulator Rods

1. **General.** Replacing strain insulator rods in place without lowering the guy, has been accomplished previously by temporarily installing long steel rods between the yoke plates. Off-air time has been required for this evolution, since a worker had to be extended beyond the face of the tower, and since the steel rods shorted out the insulators. However, by utilizing the principles of Evolution #3 (previously described), and by using spare insulator rods instead of steel rods, the entire procedure has been accomplished with the tower energized. Replacement of insulator rods while the tower is energized has also been accomplished using temporary guys made of non-conductive material.

2. Guidelines.

- a. See Guidelines for Evolution #3.
- b. Three alternative methods are suggested for transferring the load from the service insulator to the auxiliary rod; the choice should be the contractors'.

3. Special Equipment.

- a. See Special Equipment for Evolution #3.
- b. Hardware as detailed on the attached sketches.
- c. Cable type hoist - puller as required.

4. Procedure.

- a. No off-air time is normally required for this evolution.
- b. See applicable Procedures for Evolution #3.
- c. Stage replacement insulators at the various guy levels. These can easily be hauled up within the tower framework, but there is always the risk of chafing.
- d. Do not remove protective covering from the rods until they are actually being passed to the extended worker for installation.
- e. Rig for Evolution #3, and extend worker to lower yoke.

Note: The following steps may be used only if the yoke plates have holes which permit attachment of the double bars or special bar. Special designs must be used if these holes are not present.

- f. Extended worker fastens the "long double bar" (see Figures E-6, E-7, E-8) to the lower yoke plate using quick-acting (q/a) pins.
- g. There are three alternative methods with which to proceed from this point:
 - (1) Method I - as shown in Figure 4A, the load is transferred from a service rod to the auxiliary rod by means of a turn buckle operated by the extended worker. A short double bar is first attached to the upper yoke plate using q/a pins.
 - (2) Method II - as shown in Figure 4B, the load is transferred from a service rod to the auxiliary rod by means of a lever mechanism operated from the tower. This procedure may be unacceptably awkward at higher guy levels. A "special bar" is first attached to the upper yoke plate using q/a pins.
 - (3) Method III - Using a turnbuckle/auxiliary rod arrangement, or omitting the turnbuckle, the load is transferred to the auxiliary rod using a hoist-puller attached to the tower (Figure 4C). No bars are attached to the upper yoke plate.

This method is preferred if the insulator rods are twisted.

- h. Using one of the above methods, the load is removed from the service rod nearest the auxiliary rod. Disconnect the tower end of this service rod before the lower end. The old rod is removed and passed to the tower.
- i. The new rod is passed to the extended worker, removing protective wrapping as it leaves the tower framework. The new rod is installed.
- j. The load is transferred from auxiliary rod to new upper rod by relaxing the load transfer mechanism.
- k. The turnbuckle and auxiliary rod are passed to the lower outer holes of the double bar(s), and the process is repeated for the lower rod replacement.
- l. Continue replacement of rods at other guys as required.
- m. If a rod which has already failed is to be replaced, Method III is the most practical means of cranking the yokes into position, so that a new rod may be installed. However, should the remaining service rod be severely twisted, or should its cross-sectional area at any point be reduced by more than 25%, the guy should be lowered in accordance with evolution #6.

NOTE: Replacement of both rods simultaneously is not authorized using the "bars" shown. If simultaneous replacement is desirable, these bars must be sized to take the full guy load, and only Method I may be used; two auxiliary rods and turnbuckles will be required.

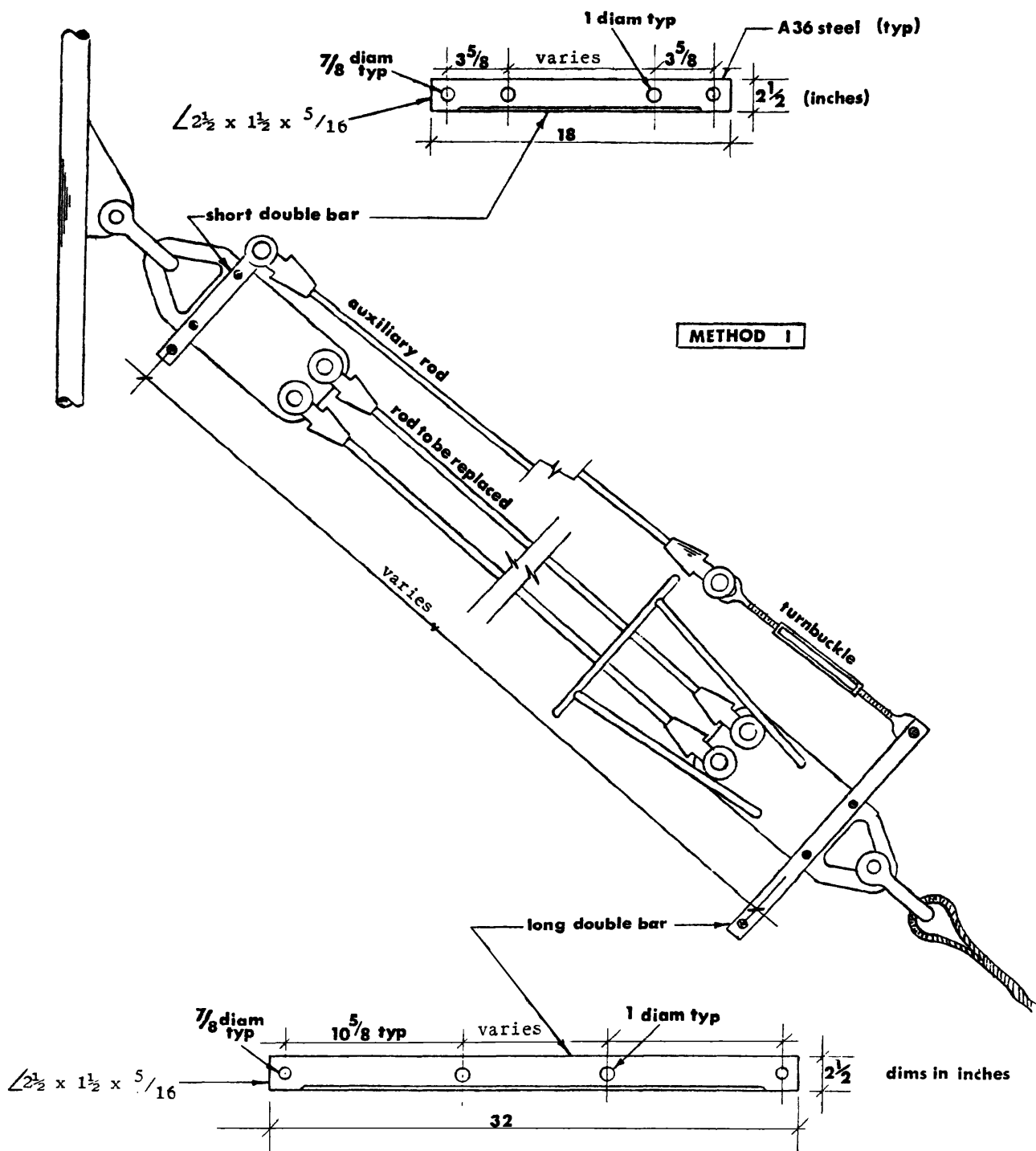
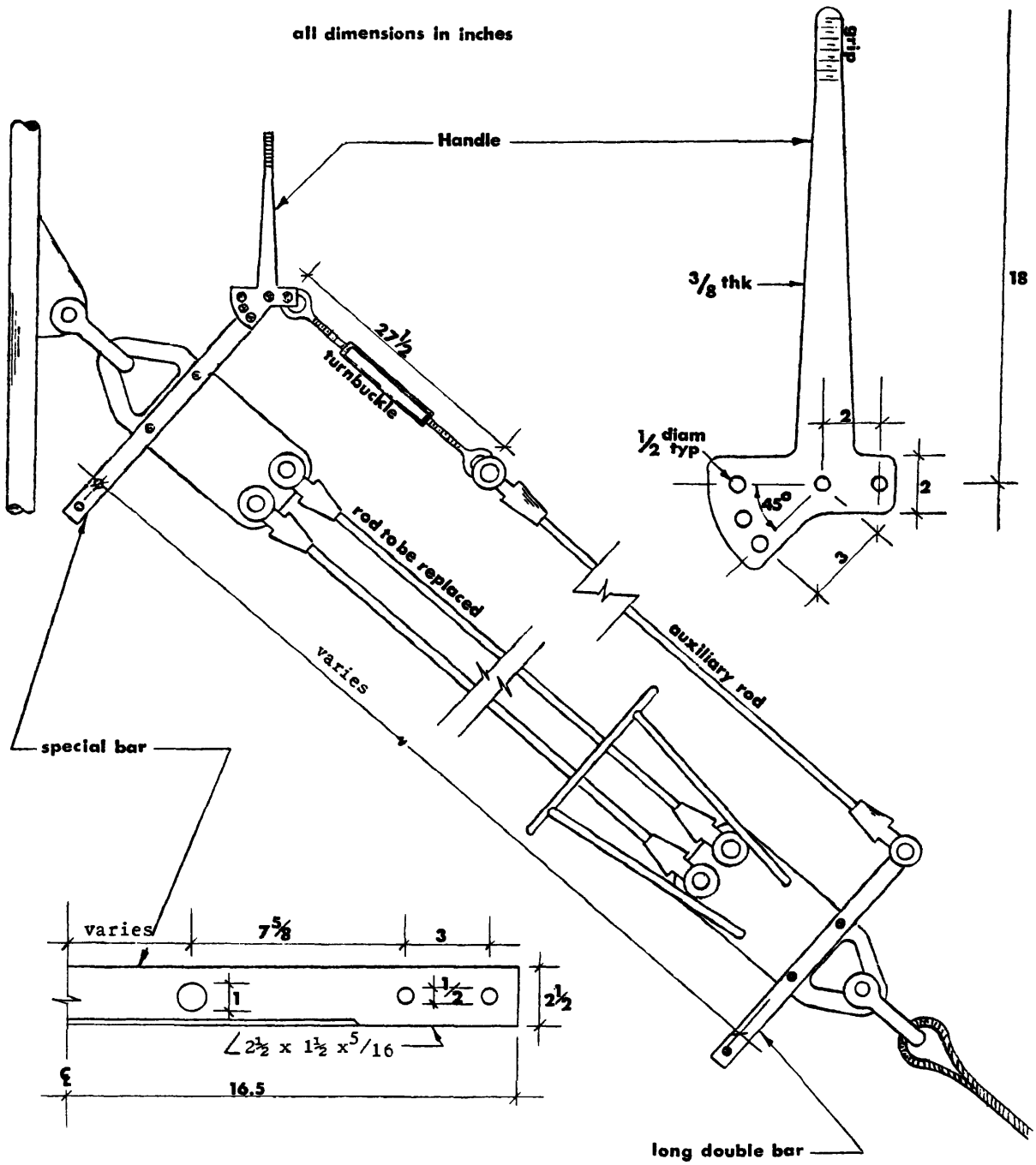

Figure E-6 Method I for Replacing Structural Guy Insulator Rods



METHOD II

Figure E-7 Method II for Replacing Structural Guy Insulator Rods

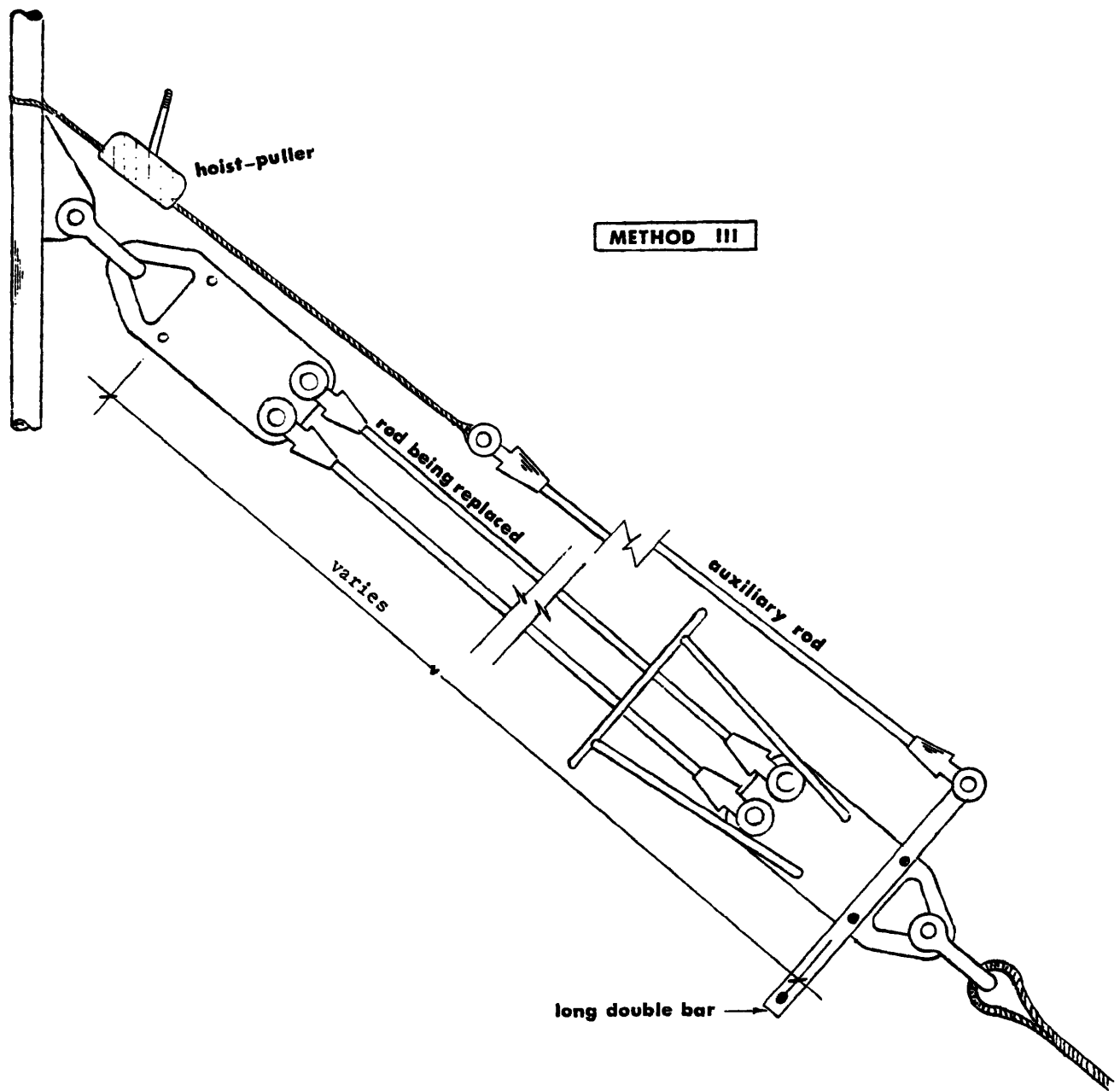

Figure E-8 Method III for Replacing Structural Guy Insulator Rods

EVOLUTION #5 - Inspecting and Replacing TLE Insulator Rods, Gradient Rings, and Radial Guy Components.

1. General. The highest voltage levels in the antenna system exist at the bottom end of the TLEs, and the strain insulators at this point have frequently failed. In the past, these insulators were inspected or replaced by lowering opposing TLE pairs into the tower, de-energizing the transmitter when they approach within 30 feet or more

of the tower structure, and performing the work off-air. Field experimentation has shown that if the TLE can be securely bonded mechanically and electrically to the framework of the tower once it is lowered into the tower, the insulators may be safely serviced without de-energizing. This evolution requires the greatest attention to detail and the greatest precautionary measures, however, because the workers on the ground are trying to manhandle a very long guy at the end of an energized cable, while proximate to the base of the tower.

THIS PROCEDURE IS NOT ADEQUATE FOR USE ON CERTAIN TOWERS WHOSE TLE LENGTH IS SUCH THAT THE UPPER END OF THE STRAIN INSULATORS CANNOT BE REACHED FROM A POINT ABOVE THE TOWER BASE PLATFORM. On these towers the Procedures of Evolution #7 may be used in order to lower the insulator assembly to the ground for inspection or servicing.

2. Guidelines.

- a. See Basic Safety Guidelines above.
- b. Positive steps should be taken to cushion radial guy breakup insulators as they reach the ground.
- c. Operations at the base of the tower should be carried out with particular attention to detail, because of the near proximity of the following conductive elements at different voltage levels: (1) the tower structure, (2) the TLE when not bonded to the tower, (3) the radial guy when not grounded, and (4) elements which are grounded. Personnel at ground potential should never handle a conductive element, such as a radial guy segment which has not been positively bonded to the ground wire or copper grounding straps at the tower base.
- d. Personnel on the tower should never handle the TLE or upper yoke plate hardware or gradient cone unless the TLE has been positively bonded to the tower.
- e. When lowering TLEs into the tower, prevent the TLE from touching any part of any structural guy, particularly the strain insulators. The TLE may touch the tower before bonding, especially if it is windward. Both before and after bonding some arcing may be heard; this is not a problem with respect to TLE or tower damage, due to the relatively short duration of the work. Before hauling a radial guy back to its anchor for reconnection, ensure that the guy and TLE are clear of all obstructions or other components on the tower and on the ground.

3. Special Equipment.

- a. Hot Stick, bonding cables, and Bonding hardware.
- b. 50 feet (50.2m), of 1/2 inch (12.7 mm) diameter nonconductive line.
- c. Auto battery jumper cables, or equivalent, with insulated handles.

- d. 850-1000 ft. (259-305m) of #4 AWG gage bare copper (or similar) stranded wire conductor.
- e. Auxiliary PLP guy-grip dead-ends for attachment to radial guys.
- f. Approximately 8 six-foot (1.83m) lengths of 1/2 inch(12.7 mm) non-conductive line.

4. Procedure.

- a. No off-air time is normally required for this evolution.
- b. Connect the end of a copper, steel, alumoweld, or other conductor of size at least #4 gage stranded wire to the ground lead or copper ground straps at the base of the tower. This conductor will be up to about 1000 feet (305m) in length, in order to extend to the radial anchors. Extend the conductor along the ground in the direction of the radial guy to be serviced.
- c. Connect a suitable winch device to an auxiliary PLP guy-grip dead-end which has been applied to the radial guy such that its eye is at least six feet (about 2m) from the eye of the PLP which connects the radial guy to the anchor turnbuckle. This auxiliary PLP should not be repositioned or reused on another guy, but should be left permanently installed. A Klein grip may also be used if a PLP is not available, but not on copperweld guys if they are not being discarded. Measure the tension in the radial guy. Remove the load from the turnbuckle, and disconnect the radial guy from the upper end of the turnbuckle.
- d. Connect a jumper cable between the #4 copper ground wire and the anchor arm or rod. Attach one end of a jumper to the #4 copper ground wire about a meter in front of the radial anchor, and the other end to the last guy segment. Be sure to connect jumper to ground wire first. (Figure E-9) Attach one end of a jumper to the last guy segment the first breakup insulator; slacken the radial guy towards the tower if necessary to reach the insulator. Short out the first insulator using the second jumper (Figure E-10).
- e. Slacken the radial guy in towards the tower. Monitor tower top deflection with a transit positioned 90° away. If deflection is excessive, the opposing radial guy must be slackened. When the next-to-ground guy segment is within reach, stop slackening. Attach a jumper to the #4 copper ground wire, then to the next-to-ground guy segment. (Figure E-11) Remove the jumper connecting the last guy segment to the #4 copper ground wire.
- f. Resume slackening. When the second insulator is within reach, short it out with a jumper, as described for the first insulator in D above.
- g. Repeat E. and F. until all insulators have jumpers installed across them, and the guy segment adjacent the fiberglass strain insulators is jumpered to the #4 copper ground wire.
- h. As the radial is slackened, jumpers from the guy segments to the #4 ground wire will tend to become taut: attach new jumpers

further along the guy as this occurs, ground wire end first, then remove the taut jumper. ENSURE THAT AT ALL TIMES THERE IS A JUMPER FROM THE HIGHEST ACCESSIBLE GUY SEGMENT TO THE #4 GROUND WIRE; other jumpers to the ground wire maybe removed.

- i. Cushion all breakup insulators using heavy matting; ensure proper grounding of all guy segments adjacent to insulators being handled. Old "Clorox" bottles cut open helically have been used as snap-on protectors for insulators.
- j. Position a worker on the tower, equipped with a hot stick (see Figure E-12). Connect to the end of the hot stick the duckbill clamp with bonding strap attached. Bond the end of the bonding cable to a tower member at least 3 ft (1m) below the point where the upper TLE yoke plate will meet the tower structure (about 10 feet (3m) above the base platform). Ensure a good electrical connection to the tower structure.
- k. Carefully lower the TLE into the tower. When the TLE is within reach of the hot stick on the tower, the TLE should be quickly bonded to the tower by attaching the duckbill clamp to the upper portion of the PLP guy-grip dead-end or to the TLE cable, and then remove the hot stick from the bonding cable.
- l. Lash the PLP guy-grip dead-end to a tower leg to stabilize the upper yoke assembly.
- m. If insulator replacement is required, it is best to have 2 workers on the tower. Run the 1/2 inch nonconductive line through the large yoke plate hole. Tie a clove hitch around one rod near the clevis tip, and with the extended bitter end tie a clove hitch around the second rod. Take the load off of the clevis pins one at a time, and remove the pins. Lower the insulators to the ground. After the ground crew attaches new insulators in a like fashion to the 1/2 inch line, haul up the new rods and install (see Figure E-13).
- n. If required, the tower crew should replace the gradient cones while the insulators are on the ground. The 1/2 inch haul lines will have to be temporarily removed.

NOTE: It may be desirable to leave to the option of the rigger the choice of following the above procedure or lowering the upper yoke plate to the ground with the gradient ring and insulators attached. There may be difficulty in loosening the bolt of the shackle, however, and before reconnecting the shackle threads should be lubricated and carefully inspected for signs of corrosion or deformation due to loosening.

- o. After servicing the TLE insulator assembly, remove the lashing and haul the TLE slowly away from the tower. When the duckbill clamp is about 3 feet (1m) from the tower, remove it using the hot stick.
- p. When hauling the radial guy back to the anchor, the shorting/grounding procedure is reversed. Before removing a guy-segment-to-ground-wire jumper, attach a similar jumper to the #4

ground wire further along the guy in the direction of the anchor. Remove the insulator jumpers as the insulators rise to about head height, unclipping the tower side first.

- q. Reconnect end of the radial guy to its anchor. Ensure that the TLE does not contact any structural guy component while hauling out.

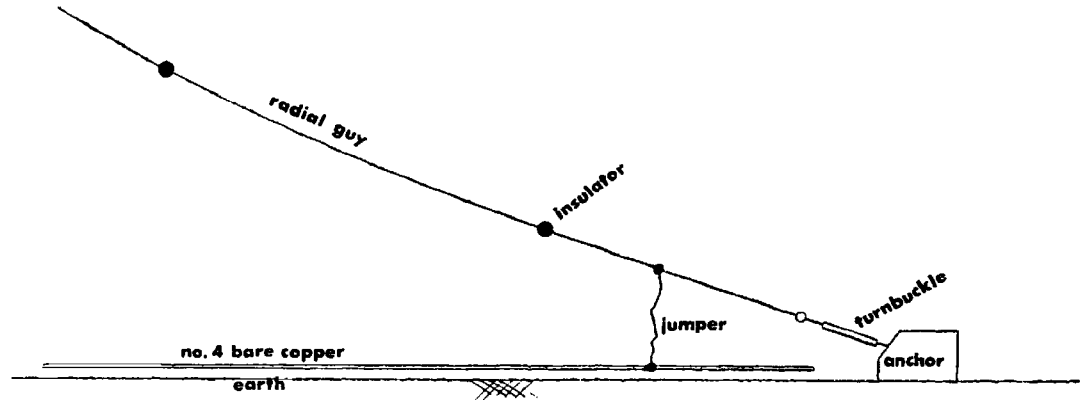

Figure E-9 Connecting jumper to guy.

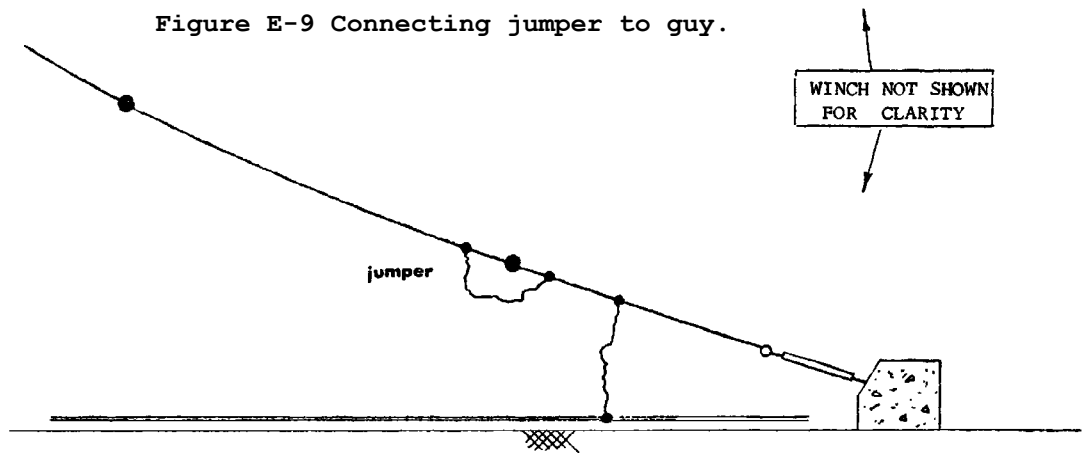

Figure E-10 Connecting jumper across break-up insulator.

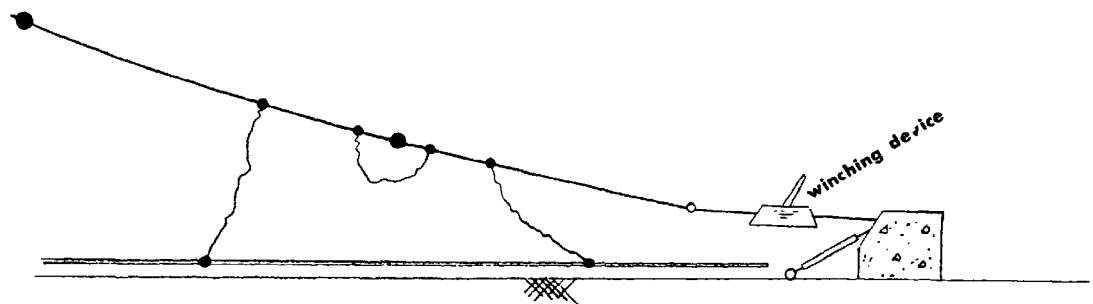

Figure E-11 Jumper wires in place across insulator and guy segments.

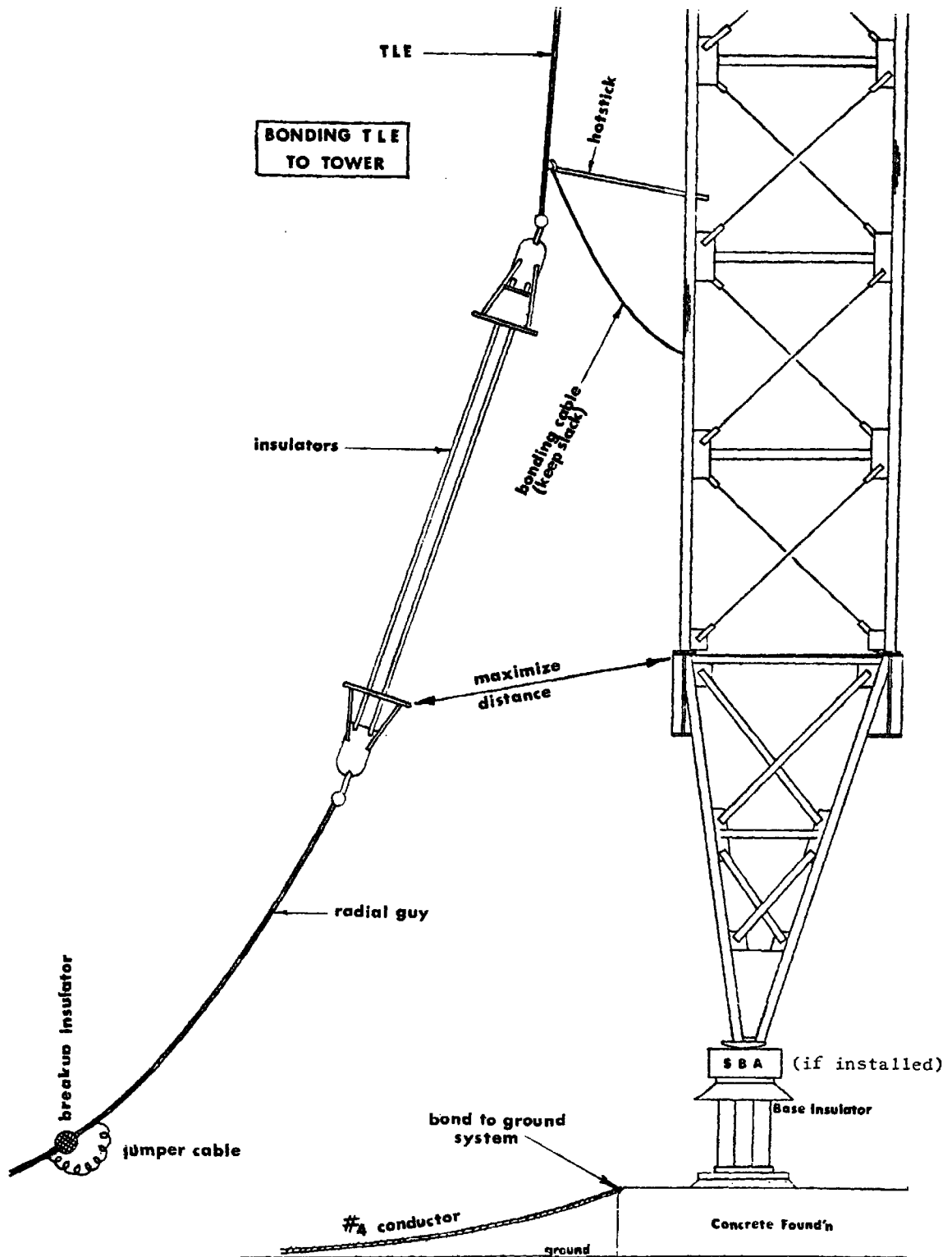

Figure E-12 Bonding TLE to Tower.

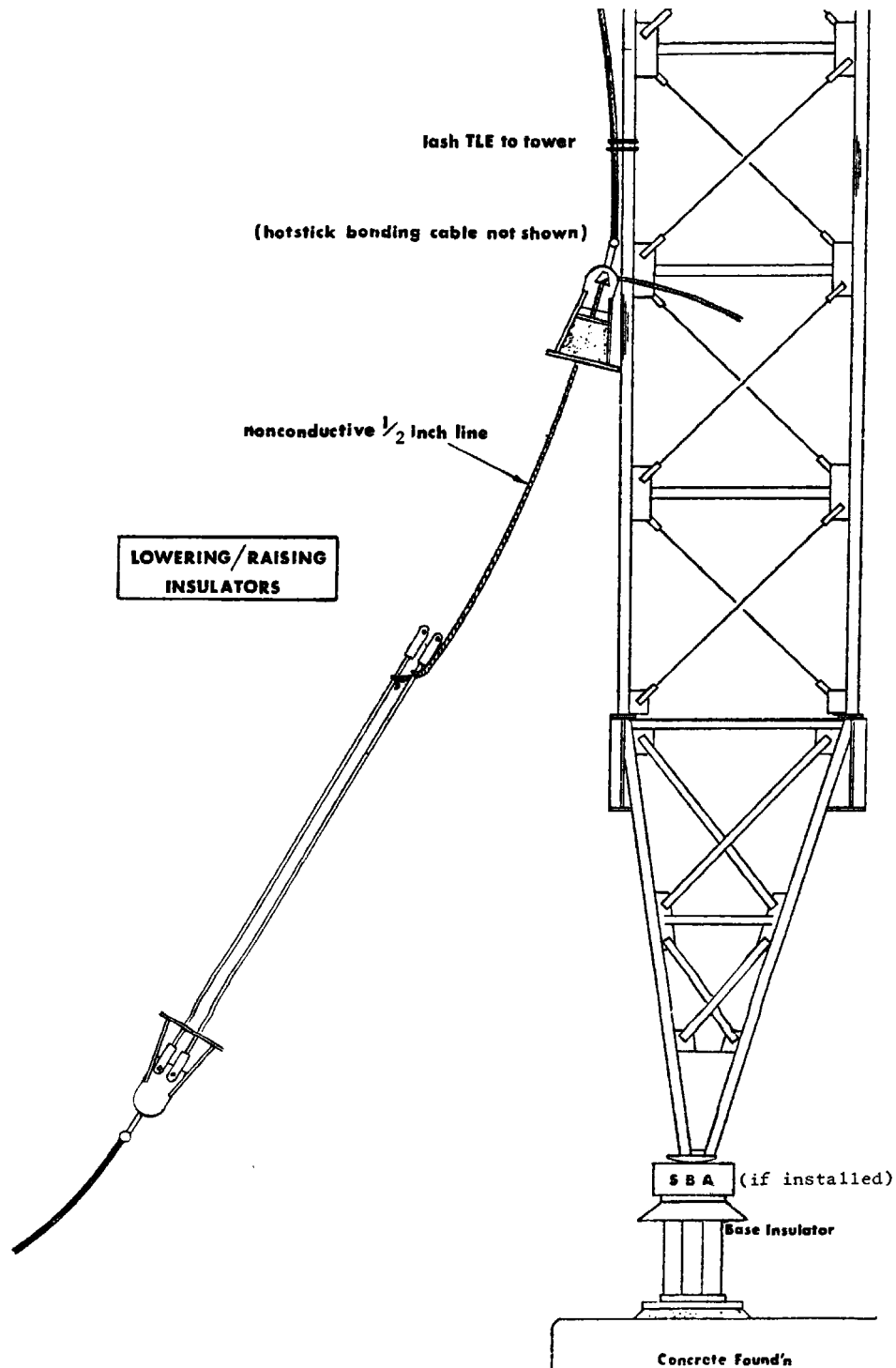

Figure E-13 Lowering and Raising Insulators

EVOLUTION #6 - Lowering a Structural Guy

1. General. A structural guy may be lowered for inspection, servicing or replacement by first installing a temporary guy in its place. This can be accomplished without de-energizing the antenna, provided that

the temporary guy and all working rigging is nonconductive line.

2. Guidelines.

- a. See Basic Safety Guidelines above.
- b. See Guidelines 2. and 5. of Evolution #5.

3. Special Equipment.

- a. 1600 ft. (488m) of nonconductive haul line.
- b. 800 ft. (244m) of nonconductive tag line.
- c. 1200 ft. (366m) nonconductive temporary guy.
- d. Haul line winch, cable type hoist-pullers.
- e. 800 ft. (244m) of #4 AWG gage bare copper (or similar) stranded wire conductor.
- f. Auto battery jumper cables, or equivalent, with insulated handles.
- g. Dynamometer

NOTE: For proper sizing of haul lines, tag lines, and temporary guys, refer to the Tower Manufacturer's Erection and Maintenance Manual or tower analysis. Size the lines to carry the following loads:

Haul Line ... 120% of the initial or "no load" tension.

Tag Lines ... 50% of the initial or "no load" tension.

Temporary Guys ... 50% of the maximum load tension.

Nonconductive Line should have an average breaking strength rating of FIVE times the above loads.

4. Procedure.

- a. No off-air time is normally required for this evolution.
- b. Raise the temporary guy, haul line, hoist-puller and tag line to the pull-off elevation of the guy to be lowered. Attach the temporary guy to the tower leg, just above the pulloff plate of the guy to be lowered.
- c. Connect the end of a stranded copper conductor, of size at least #4 gage, to the ground lead or copper ground straps at the base of the tower. This conductor will be up to 800 feet (244m) in length in order to extend to the outer structural anchors. Extend the conductor along the ground in the direction of the structural guy to be lowered.

- d. Measure the tension in the guy to be lowered.
- e. Station a transit 90° away from the lane of the guy being lowered. Continuously monitor tower deflection while load is transferred to the temporary guy. Connect the temporary guy at the anchor end, and transfer the load of the guy to be lowered. For face-guyed towers, the temporary guy may be connected to the adjacent anchor arm.
- f. Disconnect the permanent guy at the anchor, and slacken in towards the tower until all tension is removed. Ground the guy segments and jumper the insulators in the manner described in Procedures 4. through 7. of evolution #5. Cushion all breakup insulators using heavy matting; ensure proper grounding of all guy segments adjacent to insulators being handled.
- g. Using a cable type hoist-puller attached to the yoke plate, release the load from the shackle at the pulloff plate and disconnect the shackle. With the shackle still attached to the yoke plate, connect the haul and tag lines to the shackle and secure the shackle bolt. Transfer the load from the hoist-puller to the haul line. NOTE: By positioning the haul line sheave above the pull-off plate, the haul line may be used to remove the load from the pull-off shackle and the hoist-puller may therefore be unnecessary.
- h. Take a strain on the tag line while slackening the haul line, and proceed to lower the guy while pulling it away from the vertical plane of the guy lane with the tag line (see Figure E-14).

NOTE: The tag line is not required for first level guys, or if the guy may be lowered in a downwind direction.
- i. When the entire guy is on the ground, service or inspect the guy as necessary. If a new guy is to be installed jumper all breakup insulators while it is on the ground.
- j. Reverse the procedure to raise and reconnect the guy, tending the tag line in order to keep the guy clear of other guys in the lane. As breakup insulators leave the ground, remove the jumpers by disconnecting the tower ends first.
- k. Reconnect the permanent guy first at the tower pull-off, then at the anchor; transfer the load from the temporary to the permanent guy, and check the tension in the permanent guy before removing the temporary guy.

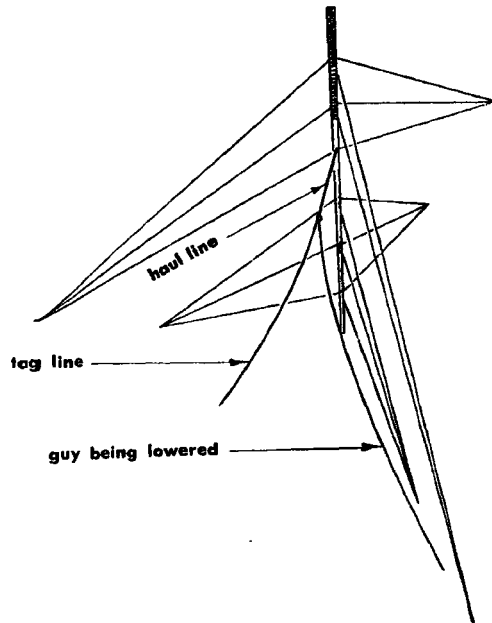

Figure E-14 This figure shows a 4th level guy being lowered. The temporary guy is not shown. The permanent guy has been slackened at the anchor end, and is being lowered via the "haul line". The "tag line" is keeping the guy clear of lower guys in the same lane.

EVOLUTION #7 - Lowering a Radial Guy & TLE

1. General. Because of the large number of radials and the relatively small tension in each, there is no need to consider the use of a temporary guy. However, to ensure that the forces on the tower remain reasonably balanced, the opposing radial should be slackened. The procedures for rigging detailed below may have to be modified somewhat for certain TLEs; experienced riggers will be able to effect necessary modifications with no difficulty. However, the steps involved in bonding and unbonding the TLEs must be strictly adhered to.
2. Guidelines.
 - a. See Basic Safety Guidelines above.
 - b. The opposing radial need only be slackened in towards the tower approximately 80 feet and secured.
3. Special Equipment.
 - a. 1800-2000 feet (550-610m) of nonconductive haul line, sized for a working load of 2000 lbs (8900N) plus line weight.
 - b. Haul line winch, cable type hoist-pullers.

- c. 850-1000 feet (260-300m) of #4 gage bare copper stranded wire conductor.
 - d. Hot sticks.
 - e. Auto battery jumper cables, or equivalent, with insulated handles.
 - f. Several 6 ft. (2m) lengths of 1/2 inch (6.4mm) nonconductive line.
4. Procedure.
- a. No off-air time is normally required for this evolution.
 - b. Raise the haul line and hoist-puller to the tower top.
 - c. Slacken the opposing radial guy in towards the tower approximately 80 feet (24m). (Refer to Procedure 2. of Evolution #5). Secure the opposing radial guy to a deadman anchor or vehicle parked sideways. Then slacken the radial guy to be serviced until no tension is in the guy. Cushion and jumper breakup insulators, following the procedures of steps 3. through 8. of Evolution #5.
 - d. At the tower top, bond the end of a hot stick bonding cable to a tower member approximately three feet (1m) below the top platform, beneath the pulloff plate of the TLE to be lowered. Connect the duckbill clip to the PLP guy-grip dead-end of the TLE to be lowered near the PLP eye (see Figure E-15).
 - e. Disconnect the pigtail of the TLE to be lowered.
 - f. Secure the standing end of a cable type hoist-puller to one of the 12 WF beams opposite the TLE to be lowered, and situate the hoist-puller on the top platform. Connect the hoist cable of the hoist-puller to the PLP eye-thimble of the TLE to be lowered (see Figure E-16).
 - g. Hang a sheave from the heavy beam to which the TLE is attached, below the TLE to be lowered to the extent possible. Run the haul line through the sheave.
 - h. Using the hoist-puller, remove the load from the shackle. Disconnect the shackle and connect to it the haul line end.
 - i. Take a load on the haul line until the shackle comes right up against the sheave. Slack off on the hoist-puller as required. This should be done slowly and carefully, with good communications to the ground, due to the large amount of stretch in nonconductive haul-lines (see Figure E-17).
 - j. Slacken the hoist-puller cable until the haul line carries all of the load. Disconnect the hoist-puller cable from the PLP eye-thimble.

NOTE: It is feasible to avoid the use of a hoist puller at the

tower top. In lieu of Steps 5. through 9. above, proceed as follows: Rig a haul line with Klein Grip attached, as shown in Figure E-18. After the TLE has been slackened from the anchor end, connect the Klein Grip to the TLE just below the ends of the PLP (or about 3 ft (1 m) below a press-type fitting if installed) (see Figure E-19). Be sure the Klein Grip is properly sized, and is designated for use on the type of TLE cable installed. Use the haul line to remove the load from the shackle at the pull-off plate and disconnect the shackle. Good communications between tower and ground are a must. Reconnect the shackle loosely to the haul line (see Figure E-20) and secure the pigtail to prevent excess movement of the end of the TLE; the haul line load is still carried by the Klein Grip.

- k. Lower the TLE until the shackle is about 3 feet (1m) from the sheave, and disconnect the duckbill clamp using the hot stick. Lower the TLE to the ground. Caution: Be sure the TLE is kept well clear of the tower and other guys as it is lowered.
- l. Cushion and jumper breakup insulators as they reach ground. As the lower end of the TLE approaches ground, bond it to the #4 ground wire using a hot stick or a jumper cable attached to the end of a hot stick telescoping pole. Do not attempt to ground the TLE with a hand held jumper cable until it has been grounded by remote means and a significant portion of the TLE cable is on the ground. DO NOT PERMIT THE GRADIENT OR CORONA RING AT THE END OF THE TLE TO TOUCH GROUND UNLESS THE TLE HAS BEEN BONDED TO THE #4 GROUND WIRE; this precaution is necessary because there is enough induced energy in the TLE to cause a fire in dry grass.
- m. Avoid contact with the TLE while it is being lowered. If it is necessary to manhandle the TLE, use short lengths of non-conductive line as a means of contact with the TLE cable. When the entire radial guy and TLE are on the ground, service and inspect as necessary.
- n. Reverse the procedure to raise and reconnect the radial guy. Refer to procedures 10, 11, and 12 of Evolution #6.

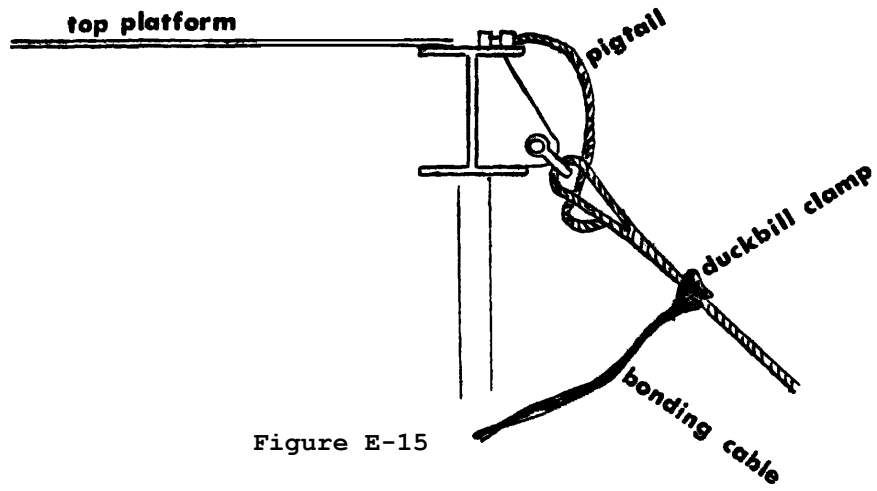

Figure E-15

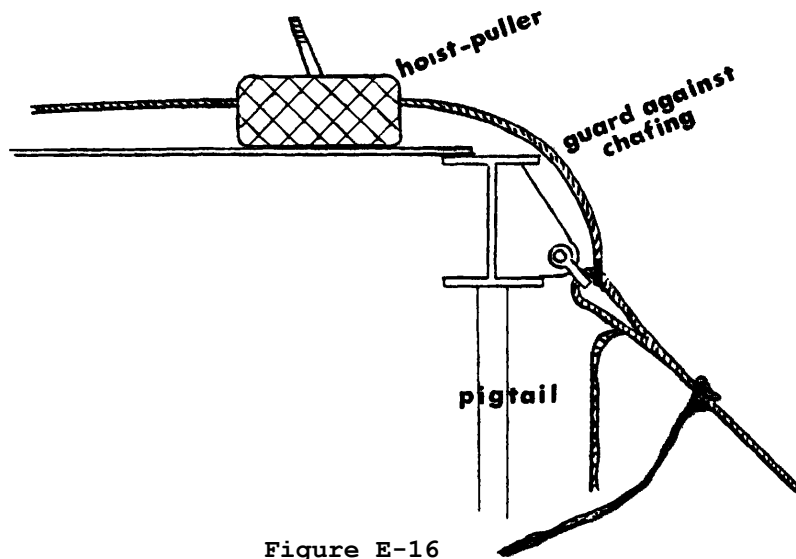

Figure E-16

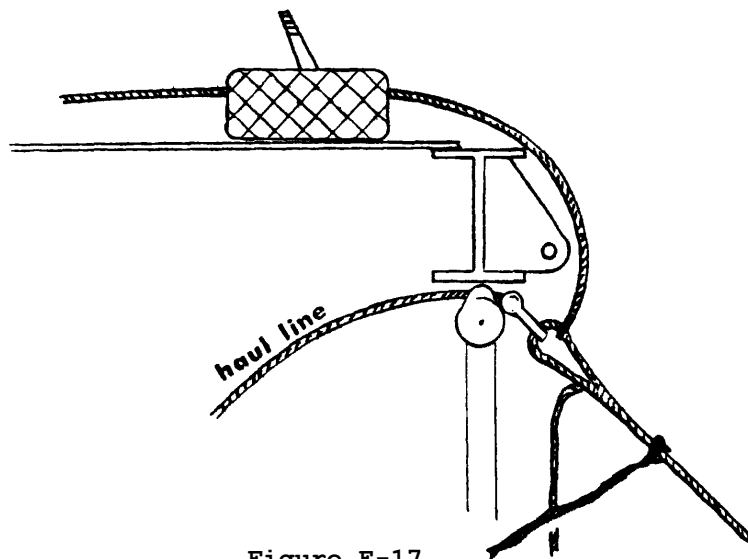

Figure E-17

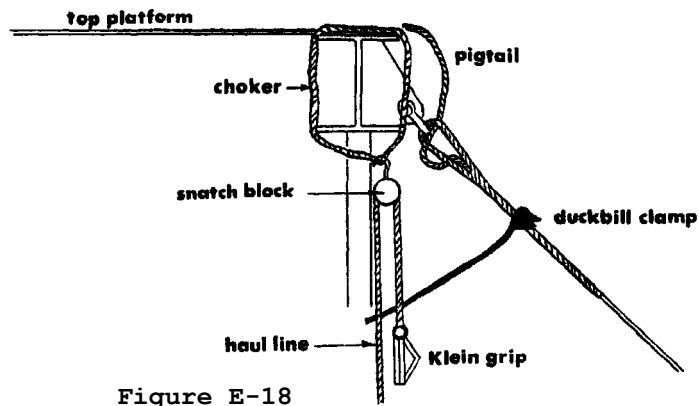

Figure E-18

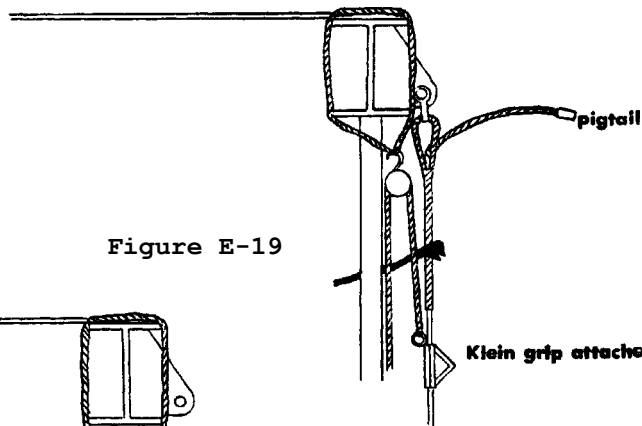

Figure E-19

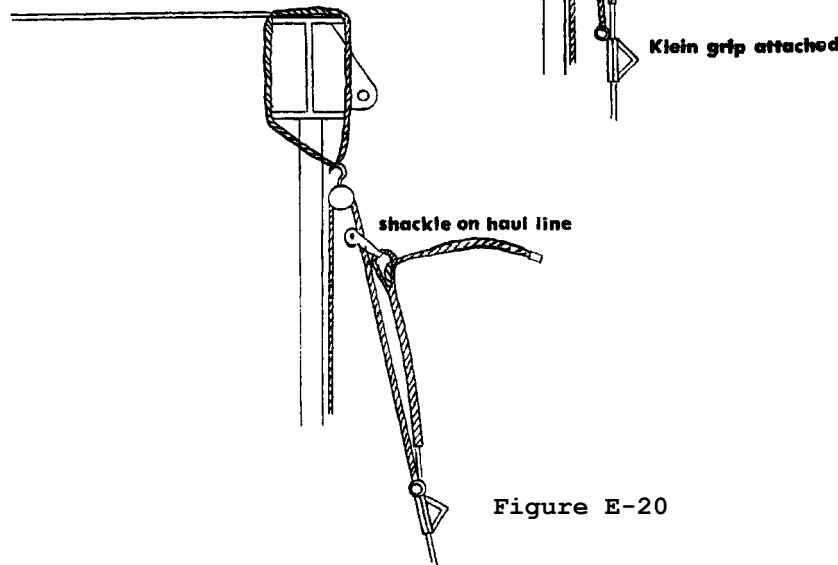

Figure E-20

EVOLUTION #8 - Servicing Base Insulators and Isolation Transformers

1. General. - The area of the base insulator is perhaps the most hazardous point in a monopole antenna system, because of the high voltage difference between the energized tower and the ground, and because the area is readily accessible. In particular, the area of the lightning gaps, where there is only a fraction of an inch between energized metal and ground, is a place where utmost caution should be exercised. Specific inspection and maintenance items on and around

the base insulator are:

- a. Cleaning of ceramic surfaces.
- b. Corrosion control of metallic surfaces.
- c. Close inspection of ceramic surfaces for cracks, by Statifluxing or similar methods.
- d. Adjustment of lightning ball gaps.
- e. Varnishing isolation transformer coils.
- f. Inspection of wiring insulation resistance, by meggering.

2. Guidelines. The above inspection and maintenance items shall only be done when the antenna tower is de-energized. However, all of these items can be fairly rapidly performed if properly planned, and some can be accomplished simultaneously, thus minimizing the necessary off-air time. In the event that off-air time is required for some purpose other than for items listed above, this opportunity should be utilized for the accomplishment of the items as time allows.

E. General Equipment Specifications. The CEU contracting the work described in this appendix is responsible to see that the proper "Special Equipment" listed for each evolution is identified in the contract specification and that a copy of this manual is made available to the contractor. This section is designed to CEUs in this respect, and also provides source of supply information if the CEU chooses to do the work "in-house". Symbols such as "PLP", "MMP", etc. refer to manufacturers whose complete addresses are listed at the end of this section.

Listing Of Special Equipment

BATTERY JUMPER CABLE - "jumper cables"; heavy duty (#3 copper cable), 12-ft. (3.7m) length.

BOATSWAIN'S CHAIR OR SEAT- "industrial work seat" or "universal work harness".

CABLE TYPE HOIST-PULLER - capacities to be based on dead loads and initial or "no-load" guy tensions; "hand hoists", "rope and chain hoists"; "hoist-pullers".

CONDUCTIVE SUIT, SOX, GLOVES- "Brunshield" suit, gloves, and socks are preferred, because of their comfort and launderability. Less desirable, but having full conductive features, are the A.B. Chance Co. suit #C402-0533, gloves #C402-0558, and socks #C402-0577. Before ordering, contact supplier for sizes, prices, and availability.

CONDUCTOR, #4 AWG GAGE WIRE - alumoweld or equal conductive capacity.

FIBERGLASS LADDER and SLIDE- consult local suppliers of protruded fiberglass products, such as Ryerson. Discuss design details with the supplier in the light of possible use of on-the-shelf protruded shapes. Pay attention to detail where ladder rests against the tower base platform, to ensure a secure connection.

HOT STICK - Hastings Fiber Glass Products, Inc. #8106 fixed shotgun stick, #4630-3 bronze clamp, #4706-4(SPL) ground clamp, 10 feet (3m) of #2 strand copper grounding cable, #C-8106 carrying case, #10-070-SPL storage bag.

HOT STICK TELESCOPING POLE - Hastings Fiber Glass Products, Inc. #SH-250 tel-o-pole hot stick with universal switch hook; universal pigtail disconnect #10-053; carrying case #C-30.

KLEIN GRIP- "Chicago" Grip, available from Klein Tools. Cite cable type, working load, and size when ordering grips.

NONCONDUCTIVE LINE - Polypropylene rope conforming to MIL-R-24049A (Type I) is preferred because of its low water absorption and relatively low elongation (35% at breaking point). Nylon rope conforming to MIL-R-17343D or Type II poly-propylene rope (MIL-R-24049A) are also acceptable, but their breaking point elongation is 55%. Doublebraided nylon rope conforming to MIL-R-24050B is very suitable; it is much stronger than polypropylene for a given size, and has a much lower elongation than nylon rope; like polypropylene, it should not be subjected to rapid running.

PLP GUY-GRIP DEAD-ENDS - should be identical in material, size, and lay to those installed on the guy cable for connection to the anchor.

QUICK-ACTING PINS - the various sizes required are available from Monroe Engineering Products, Inc. & Medalist Leitzke, among others.

SAFETY SNAP, LARGE - "safety snap", wide or extra-wide throat.

TURNBUCKLE - contact local suppliers for availability of turnbuckle proportioned for size and takeup required.

WINCHES - provision of winches of proper drum size and capacity should be the contractor's responsibility.

LISTING OF COMMON SUPPLIERS:

Preformed Line Products, Inc.
Box 91129
Cleveland, OH 44101

McMaster-Carr Supply Company
PO Box 4355
Chicago, IL 60680

Hastings Fiber Glass Products, Inc.
Hastings, Mich. 49058

A.B. Chance Co.
Utility Systems Division
Centralia, MO 65240

Standard Handling Devices, Inc.
PO Box 13Y
8 Sycamore Ave.

Medford, MA 02155

Monroe Engineering Products, Inc.
Farmington Industrial Park
PO Box 127
Farmington, Mich. 48024

Medalist Leitzke
Box 305
Hustisford, Wis. 53034

Klein Tools and Safety Equipment
7300 McCormick Rd.
Chicago, IL 60645
(Catalog Contains many items of use to Riggers)

F. RIDING TALL TOWER GUYS

1. General. Riding the guys of is an acceptable method of inspecting the guys and insulators on the tallest of towers. The tower must be de-energized when the guys are being ridden. The methods outlined below have been successfully used in the past. However, specifications for riding the guys should be "performance" type and should not incorporate the descriptions below.
2. Ring Method. In this method the inspector literally rides down the guy from the tower to the ground. See Figure E-21. A bosun chair is suspended from a supporting ring which straddles the guy wire. A large sheave is contained in the ring that actually rides on the guy. The ring must have a connection to allow it to be passed around the guy and it and/or the chair support must also have haul lines attached to control the movement of the ring down the guy. The presence of compression cone guy insulators on these tall towers requires that the ring be large enough to pass over the insulators. It also requires the use of a come-along or similar device by the person riding in the chair. This is used to winch the chair upwards to relieve the load on the sheave. The ring is then passed by hand around the insulator and the load again transferred to the sheave. In addition, it is necessary to climb out over the compression cone insulator clusters at the tower end of the guys to first attach the ring. Understandably, close coordination and reliable communication with the persons tending the haul lines are a prerequisite to this operation.
 - a. Advantages.
 - (1) Heavy equipment and rigging is not required on the ground or tower.
 - (2) The lower portion of the guys and insulators can be inspected at close range.
 - b. Disadvantages.
 - (1) Only two guys can be inspected in a ten hour workday. This is because of the manual labor involved in handling the haul

lines, climbing the tower to the respective guy levels, and winching around the insulators.

- (2) It is difficult and potentially hazardous to climb out over the cluster insulators and attach the ring to the guy. Two persons may be required for this operation. Mounting of the bosun chair by the inspector is also difficult.
- (3) The inspector lacks mobility.
- (4) It is difficult, if not impossible, to inspect the upper portion of the insulators and guys.
- (5) It is difficult to pass the ring around the insulators.

3. Basket Method #1. In this method a mechanically powered hoist is used to raise and lower the inspector in a steel basket alongside the guy wire. See Figure E-22. A haul line and two tag lines are required to control the movement of the basket. The inspector mounts the basket on the ground and then directs the hoist operator and line tenders on the movement of the basket. The haul line should be rigged as close as possible to the top of the tower to reduce the tensions in the lines and to minimize the necessity to adjust the rigging when inspecting more than one guy in each lane. Close coordination and reliable communication with persons tending the haul and tag lines are a prerequisite to this operation.

a. Advantages.

- (1) As many as five guys may be inspected in a 10 hour workday.
- (2) The guys and insulators may be inspected from any angle as required.
- (3) The inspector is more mobile and comfortable and is not required to perform strenuous winching operations.

b. Disadvantages.

- (1) This method requires heavy equipment and rigging.
- (2) There is a tendency for the rigging lines to become fouled on guy insulators.
- (3) Repositioning of rigging to inspect more than one guy lane is time consuming.
- (4) At times, because of high winds, the basket cannot be pulled close enough to the guy.

4. Basket Method #2. This method uses a rigging procedure which is slightly different from Basket Method 1. The rigging for this method is shown in Figure E-23. The basket is supported by a harness and sheave arrangement, which hangs from the "support line". Two mechanically powered hoists are required; one controls the tension in the "support line", providing close control over the basket's vertical position and the other hoist controls the horizontal

positioning of the basket along the guy, by means of the "haul line". A tag line may also be required to counter wind blowing perpendicularly to the guy lane. Nonconductive line has been used in this method (a nylon support line and polypropylene haul line), but due to the stretch of the line the highest level could not be inspected. The advantages and disadvantages of this method are similar to those of Basket Method 1 except that two hoists may be required.

5. Nonconductive Line. Nonconductive line may be used for tower-to-ground rigging in any of the three methods discussed. Its use will permit re-energizing the tower overnight or during long periods when no work is accomplished. If the tower is to be energized, all lines leading from tower to ground should be pulled tight to remove slack. Safety markers should be attached to or placed near all hoists and portions of the lines which are proximate to the ground. If wet, these lines may carry some RF current from the tower.

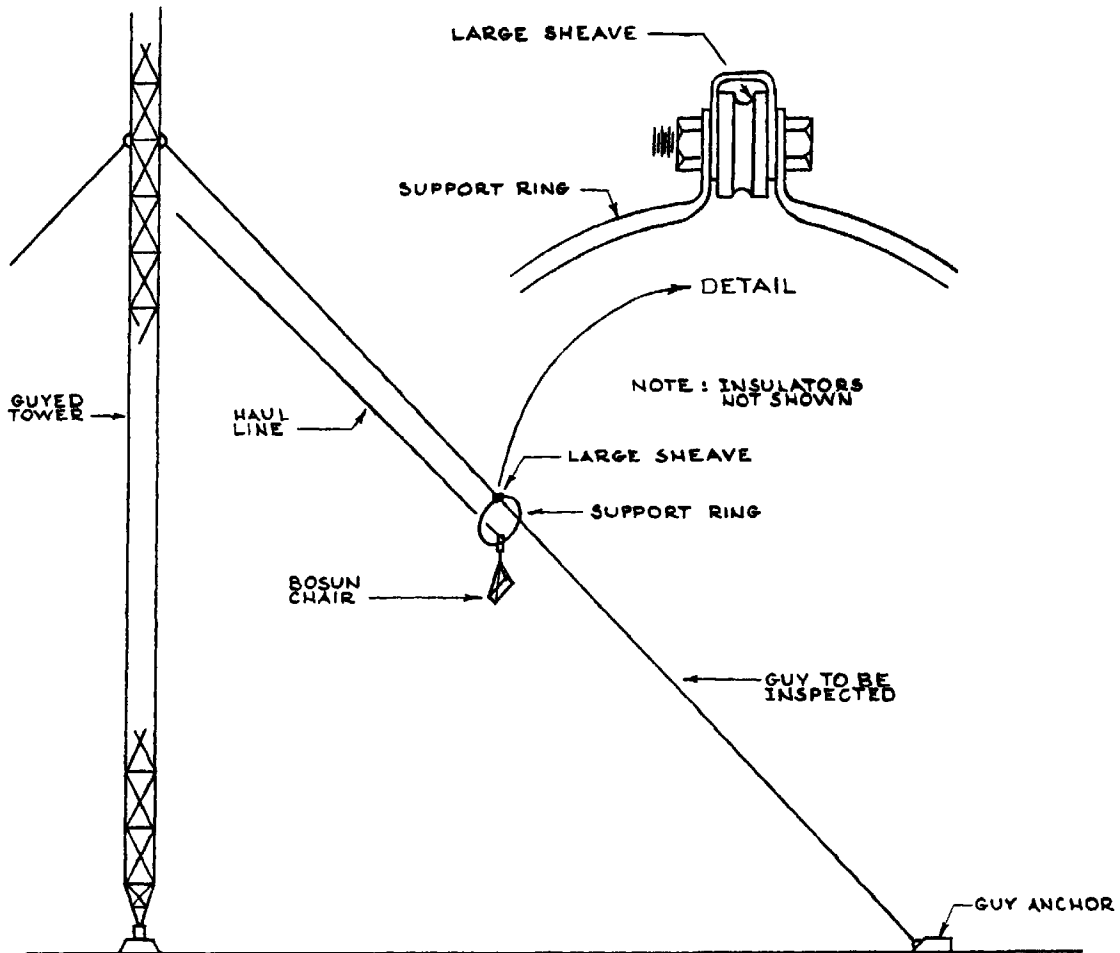

Figure E-21 Ring Method

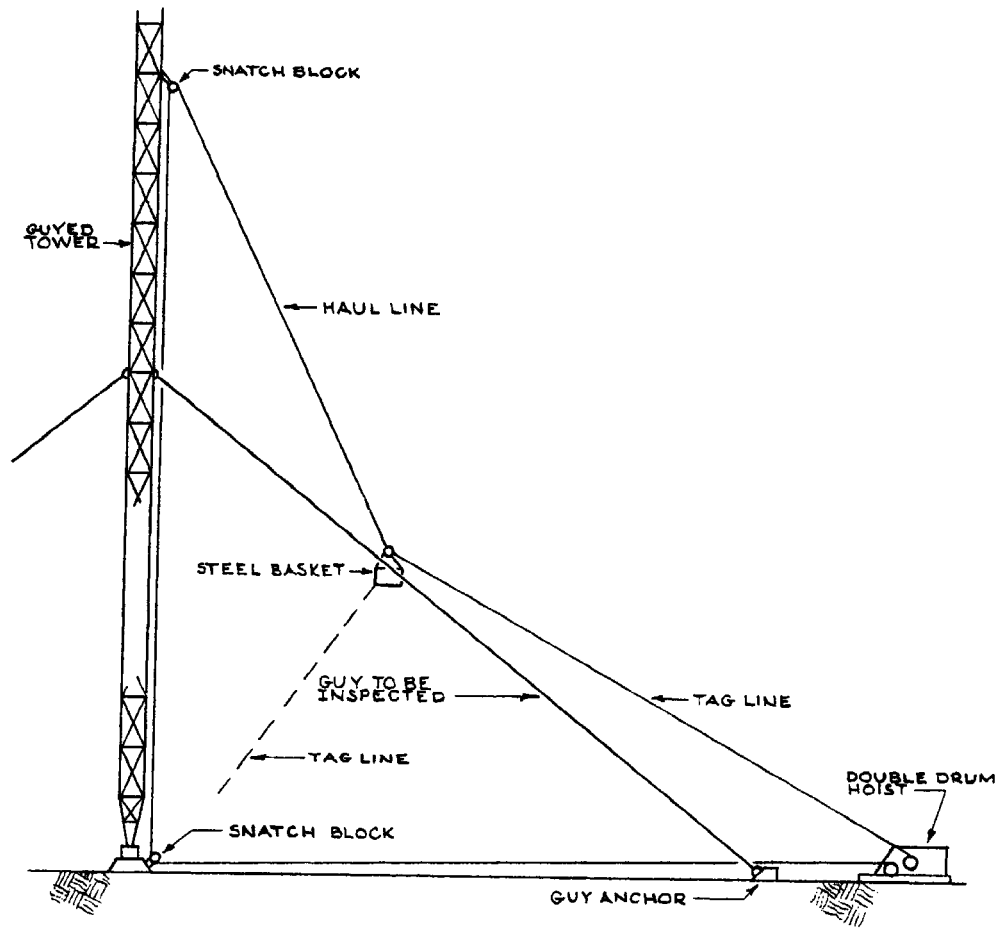

Figure E-22 Basket Method #1

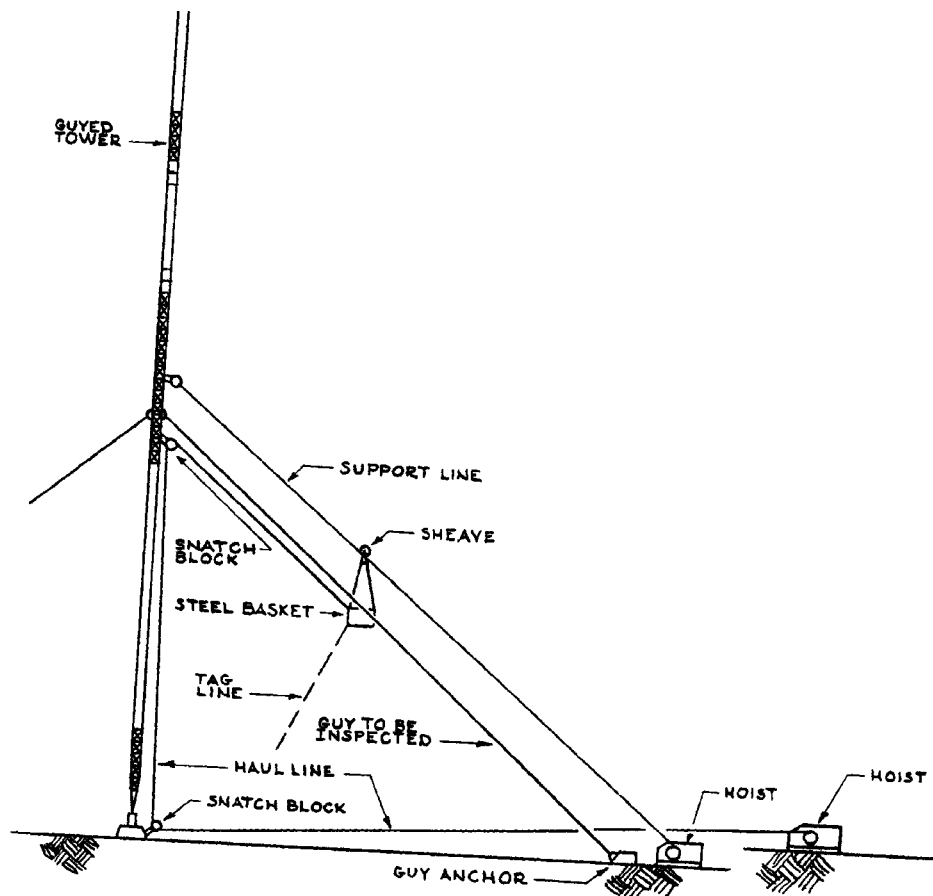

Figure E-23 Basket Method #2.

G. STATIFLUXING

1. "Statiflux" is a trade name of the Magnaflux Corporation for an ionized particle inspection method. This is a simple, non-destructive method for the detection of cracks in non-conducting materials such as ceramic insulators by means of electrostatically charged particles. This method can produce erroneous results if not performed properly.
2. This method is used on ceramic insulators as follows:
 - a. The insulator is washed with hot water containing a wetting agent. This agent enters any discontinuities and acts as a conductive material.
 - b. The surface is dried with a cloth, air blast, hot air drier, or other suitable means.
 - c. A cloud of fine electrostatically charged particles is blown onto the surface to be inspected. These powdery particles are held electrostatically at the defect. They quickly build up into a visible indication of the crack or discontinuity.

3. Specially developed powder guns and nozzles are used to blow the powder in a dispersed cloud. Each particle is dynamically charged by its passage through the nozzle, and holds its charge when applied to the surface of the material being inspected. The materials used in this process are harmless.
4. Since most compressed air systems contain moisture or oil droplets, it is necessary to use a moisture and oil filter trap with this gun. In the application of the powder the gun should be held approximately two to four (inches from the insulator surface; a gentle shaking action during application will assist in developing a good powder cloud. The air pressure is not critical, and is usually in the range of 15 to 25 psi. This can be obtained from an air cylinder, or even from an inflated spare tire by use of a special adapter.
5. Figure E-24 shows statifluxing of a base insulator.



Figure E-24 Results of Statifluxing a Base Insulator. The powder indicates cracks not otherwise visible.

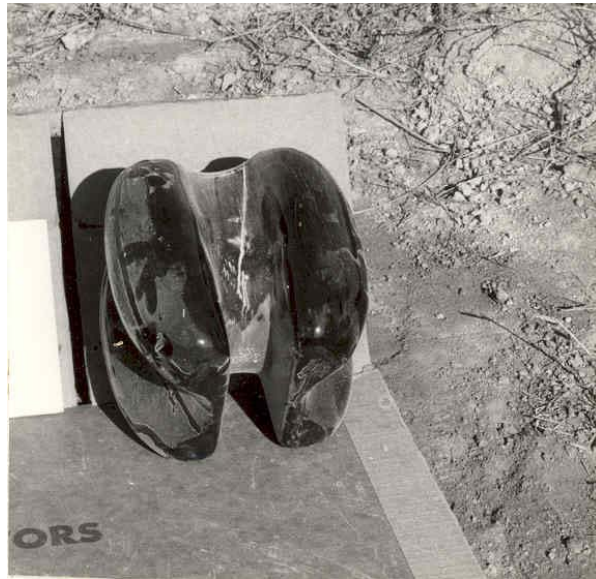

Figure E-25 Results of Statifluxing an open-end johnny-ball type insulator.
A crack can be seen in the groove.